

5

Software demo/test Application

The DT50 can be paired and communicate with any classic Bluetooth device. This allows the user to create serial to Bluetooth and/or Bluetooth to I/O control application. Diamond Technologies provides Windows, Android, and IOS based demo/test applications as well as an API interface to assist users in configuration and program development. These tools can be found at www.diamondt.com, on Google Play, and on iTunes.

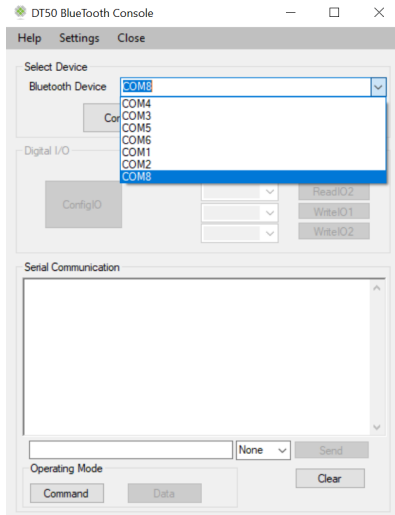

The following example utilizes the Windows application to connect, configure and communicate through Bluetooth with the DT50 Bluetooth Gateway.

To establish a Bluetooth connection with the DT50 you need to first add the DT50 to your computer devices as described in Section 4. Then start the Windows DT50 application and select the correct Bluetooth outgoing COM port as shown in Figure 5.

The blue light on the DT50 will illuminate once the Bluetooth connection has been established. The DT50 Windows Application will now display the main control console screen as shown in Figure 6.

After a connection is established Serial data can then be exchanged between your PC and the Serial port connector on the DT50. Ensure that your serial device is set to the default serial port settings as outlined in Step 2 of this guide. In Figure 6 serial port data is displayed in the Serial Communications window of the DT50 application.

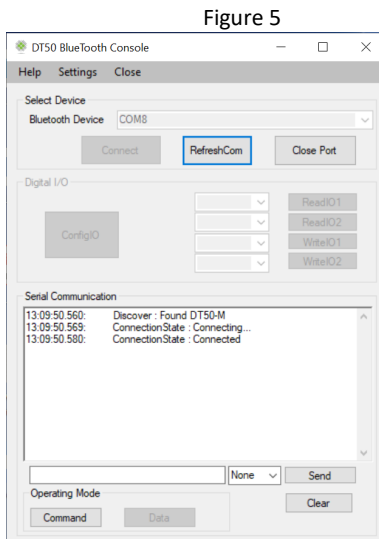

Figure 5

Figure 6

Changing Serial Communications Parameters

The DT50 application can also be used to change the default serial port settings of the DT50. To access the serial settings, first put the DT50 into I/O Mode by clicking the I/O Mode button at the top left of the screen. Then select Settings at the top of the application main window. The serial settings dialog will be displayed as shown in Figure 7. Change serial port settings to desired values and click Set. The new settings will be saved in the DT50.

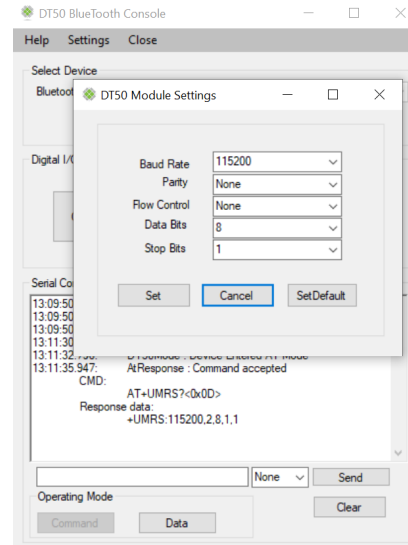

Figure 7

Controlling and Monitoring Digital I/O

The DT50 application can also be used to control the DT50 digital outputs and monitor the digital inputs. In order to control and monitor the I/O, you first need to ensure that the DT50 is in I/O mode by clicking the I/O Mode button at the top left of the main application window. The screen of the DT50 Application will then appear as shown in Figure 8.

Note: When in I/O mode the DT50 will no longer exchange serial communications.

The DT50 digital outputs can now be turned on or off by selecting/deselecting the check boxes. The state of the DT50 digital inputs can be monitored by observing the Input0 and Input1 indicator lights on the application display.

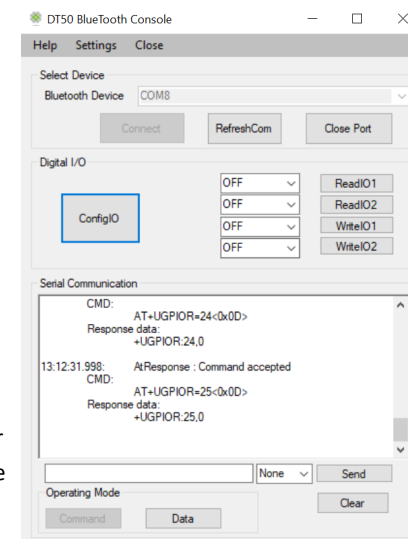

Figure 8

DT50 Bluetooth Gateway



Rev 2.00, 0721



**43 Broad Street
Unit C103
Hudson, MA 01749
USA**

Tel: 978-461-1140 Toll Free: 866-837-1931

Fax: 978-461-1146

www.diamondt.com

©2021 Diamond Technologies Inc

1

Overview

The DT50 Bluetooth Gateway is an easy to use serial to Bluetooth converter which incorporates Digital I/O. As a Serial Converter it supports RS232 and RS485 (RS422 model available). The Digital I/O can be controlled remotely from the Bluetooth interface, providing the ability to turn on and off devices remotely, as well as monitor the state of inputs. The DT50 includes an embedded Bluetooth stack and is fully Bluetooth qualified, providing the ability to interface to any Bluetooth compatible device.

Diamond Technologies also provides a Windows based test and configuration tool as well as Android and IOS test apps.

2

Serial Connections

Serial Port Connector RS232/RS485 DB9 female

NOTE: RS422 model available—contact factory

Pin	Function
1	D+ RS485
2	TX RS232
3	RX RS232
4	Vin (+5 - +15VDC*)
5	GND
6	D- RS485
7	CTS
8	RTS
9	NC

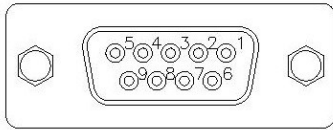

Default Serial Communication Settings:

57.6 kbits/s , 8 Data bits, 1 Stop Bit, No Parity, and No Flow Control

Power

The DT50 can be powered either via the serial connector, pins 4 and 5, or via the I/O connector, pins 13 and 14. Note, when using the serial connector the voltage range is **+5 to +15VDC*** while using the I/O connector the range is **+9 to +30VDC**.

When power is applied to either the I/O connector or serial connector the PWR and MODE LEDs on the face of the DT50 will be green. Note, many devices will supply small amounts of power on Pin4 (DTR) of a standard serial port. This power may light the green PWR LED, but it is typically insufficient power for the module to operate properly.

***Note: +6 to +15VDC** may be required for proper RS485 operation.

3

I/O Connections

I/O Connector 14 pin pluggable Terminal Block

Pin	Function	Pin	Function
1	DI1 +	2	DI1 -
3	DI2 +	4	DI2 -
5	DO1 +	6	DO1-
7	DO2 +	8	DO2 -
9	Reserved	10	Reserved
11	Reserved	12	Reserved
13	V+ (+9 - +30VDC)	14	GND

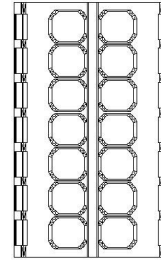

The 14 pin pluggable I/O connector uses spring pressure termination connections. Connection points are opened by inserting a thin blade screw driver into the sides of the connector. This actuates and opens the top spring connections. The below diagrams depict the wiring of DI and DO I/O on the DT50 Terminal block connections

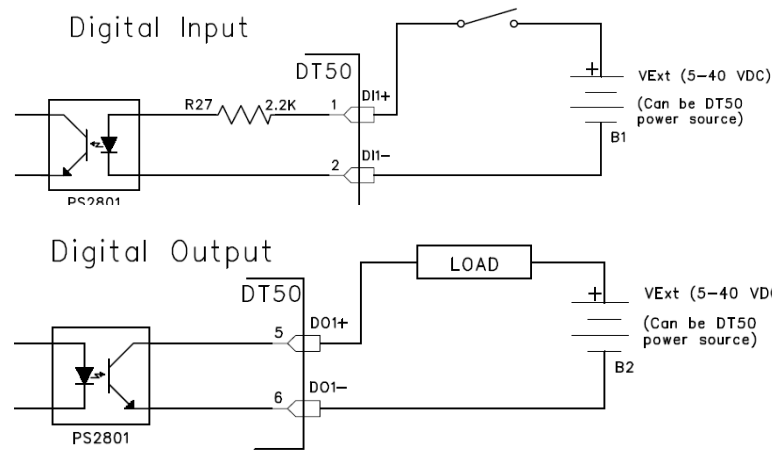

4

Bluetooth Serial Port Device Setup

The DT50 provides a very easy to use serial cable replacement solution between a PC and a serial device. In order to use the serial port of the DT50 in a Windows based application it is necessary to first Add the DT50 to your PC Devices and Printers selection. First click on Windows Start > Devices and Printers. In Device and Printers select Add a Device as shown in Figure 1.

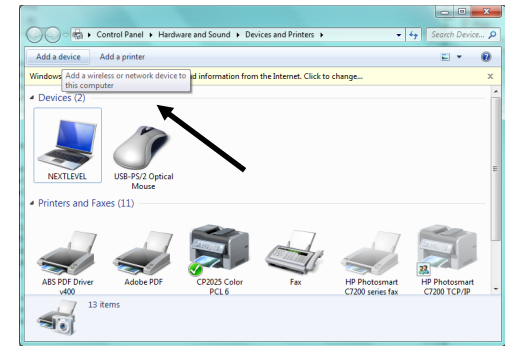

Figure 1

The “Select a device to add to this computer” selection box will then be displayed showing all available devices . Select the DT50 as shown in Figure 2 and click Next.

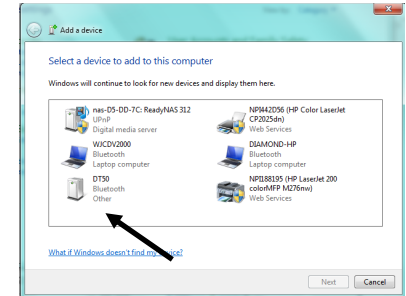

Figure 2

After the DT50 has been successfully added to your PC available Devices and Printers list you can right click on the DT50 properties. This displays the SPP service now available with your DT50 and lists the outgoing COM port which has been assigned to the DT50. This is shown in Figure 3. Note: Windows will setup (2) Bluetooth COM ports for you; one is for incoming connections and one is for outgoing connections. You will utilize the outgoing connections port later in this guide.

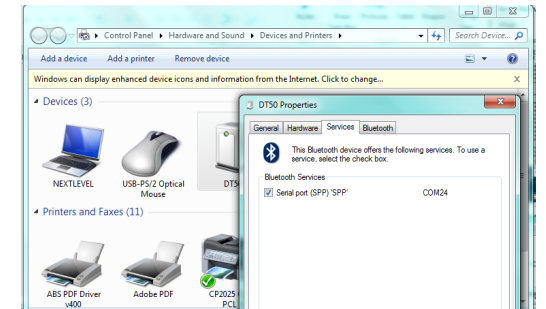

Figure 3

The DT50 COM port can now be used in serial applications. In order to have proper communications with your serial devices the serial port settings of the serial port on the DT50 must match your serial device. To change the DT50 serial port settings see section 5 of this guide. Note: There is no need to change the serial port settings of the Bluetooth COM port which was configured in this section. The communications between your PC and the DT50 will utilize Bluetooth.