

# DS8110

## Barcode Scanner

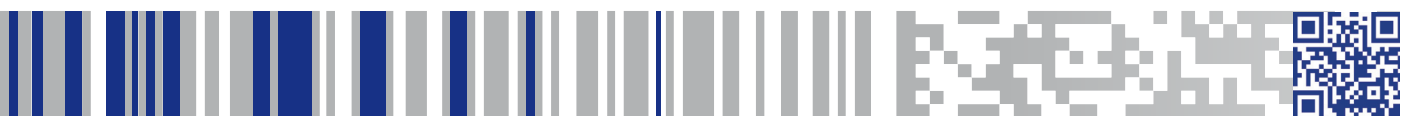

**Reference Manual**

Datalogic S.r.l.  
Via S. Vitalino 13  
40012 Calderara di Reno  
Italy

DS8110 Barcode Scanner Reference Manual

Ed.: 04/2019

This manual refers to software version 3.6.1 and later.

© 2015 - 2019 Datalogic S.p.A. and/or its affiliates ♦ ALL RIGHTS RESERVED. ♦  
Without limiting the rights under copyright, no part of this documentation may be reproduced, stored in or introduced into a retrieval system, or transmitted in any form or by any means, or for any purpose, without the express written permission of Datalogic S.p.A. and/or its affiliates.

Datalogic and the Datalogic logo are registered trademarks of Datalogic S.p.A. in many countries, including the U.S.A. and the E.U.

PackTrack, ACR, ASTRA and X-PRESS are trademarks of Datalogic S.p.A. and/or of its affiliates. All other trademarks and brands are property of their respective owners.

Datalogic shall not be liable for technical or editorial errors or omissions contained herein, nor for incidental or consequential damages resulting from the use of this material.



# Contents

<b>REFERENCES</b> .....	<b>VII</b>
Reference Documentation .....	vii
Support Through the Website .....	vii
Patents .....	vii
<b>CONVENTIONS</b> .....	<b>VIII</b>
<b>COMPLIANCE</b> .....	<b>IX</b>
<b>Electrical Safety</b> .....	<b>ix</b>
Laser Safety .....	ix
Standard Regulations .....	ix
<b>Bureau of Indian Standard (BIS)</b> .....	<b>ix</b>
Warning and Serial labels .....	x
<b>Power Supply</b> .....	<b>xi</b>
<b>CSA Certified</b> .....	<b>xi</b>
<b>CE Compliance</b> .....	<b>xi</b>
<b>EAC Compliance</b> .....	<b>xi</b>
<b>FCC Compliance</b> .....	<b>xii</b>
<b>INTRODUCTION</b> .....	<b>1</b>
<b>Product Description</b> .....	<b>1</b>
<b>General View</b> .....	<b>2</b>
<b>Applications</b> .....	<b>3</b>
<b>Model Description</b> .....	<b>5</b>
<b>DS8110 versions</b> .....	<b>5</b>
<b>X-PRESS (Human Machine Interface)</b> .....	<b>5</b>
<b>Accessories</b> .....	<b>6</b>
<b>Photoelectric Sensor</b> .....	<b>8</b>
<b>Encoder (Tachometer)</b> .....	<b>9</b>
Encoder/Tachometer Step Settings .....	9
Photocraft Encoder/Tachometer Switch Setting .....	10
<b>CBX Industrial Connection Box</b> .....	<b>11</b>
<b>SC5000 System Controller</b> .....	<b>12</b>
<b>MECHANICAL INSTALLATION</b> .....	<b>13</b>
<b>Preparing for Mechanical Installation</b> .....	<b>13</b>
<b>Unpacking Instructions</b> .....	<b>14</b>
<b>Installation Sequence</b> .....	<b>14</b>
<b>What You Need to Know About Your Application</b> .....	<b>15</b>
<b>Installation</b> .....	<b>16</b>
Dimensions and Clearances .....	16
Physical Support Requirements .....	16
Vibration Limitations .....	16
General Mounting Guidelines .....	17
Mounting Structure Considerations .....	17
Mounting the Scanner .....	18
<b>Positioning the Scanners</b> .....	<b>20</b>
<b>ELECTRICAL INSTALLATION</b> .....	<b>21</b>
<b>Preparing for Electrical Installation</b> .....	<b>21</b>
<b>Connecting a DS8110 Scanner</b> .....	<b>22</b>
<b>Typical Connection Block Diagrams</b> .....	<b>23</b>
Single DS8110 Barcode Scanner to CBX510 .....	23

- Master/Slave Array with CBX510 .....24
- DS8110 Barcode Scanners in an Array with SC5000 Master .....24
- General Electrical Installation Guidelines .....25**
- DS8110 Connector Panels .....26**
- Connecting a PC to the DS8110 .....27**
- Power Connector Pin-Out Table .....27**
- Power Connections .....27**
- CBX510 Connection Box .....28**
  - Wiring Into the CBX510 Connection Box .....28
- Main Serial Interface .....29**
  - RS232 Interface .....29
  - RS232 Interface .....29
  - RS422 Full-Duplex Interface .....30
- Photoelectric Sensor Connections to CBX510 .....31**
  - Photoelectric Sensor (NPN) .....32
  - Photoelectric Sensor (PNP) .....33
- Tachometer Wiring to CBX510 .....33**
  - Encoder/Tachometer Wiring for NPN Output (two models) .....34
  - Encoder/Tachometer Wiring for PNP Output (two models) .....36
- Digital Output Configuration to CBX510 .....38**
  - Unpowered Outputs .....39
  - Powered Outputs .....39
- CBX100 Connection Box .....40**
  - Connecting to the SC5000 System Controller (Optional) .....41
- Grounding .....42**
- Check Scanner Installation .....42**
- E-GENIUS..... 43**
  - Getting Started .....43**
    - Prerequisites .....43
    - Starting e-Genius .....43
    - Monitor Mode .....45
  - e-Genius Basics .....47**
    - e-Genius Menu Tree .....47
    - Entering Text Using the Text Entry Tool .....47
    - Update and Reset Buttons .....48
    - Disabled Check Boxes .....48
    - Getting Help .....48
  - System Information .....49**
  - Modify Settings .....52**
  - Operating Mode .....54**
  - Barcode Settings Table .....68**
  - Barcode Configuration .....75**
  - Understanding Barcode Configurations .....76**
    - No Read Messages .....76
  - Single Label .....79**
  - Standard Multi Label .....83**
  - Logical Combination .....87**
  - Barcode Configuration | Code Collection .....97**
  - Serial Ports .....102**
    - Main Serial Port .....103
    - Aux Serial Port .....106
  - Ethernet .....108**
    - Ethernet | Line Settings .....109
    - Ethernet | User Sockets .....111
    - Ethernet | Ethernet\_IP .....115
    - Ethernet | WebSentinel .....119
  - Fieldbus .....121**
    - Messaging .....126
  - Messaging | Message Format .....127**
  - Messaging | Message Builder .....139**
  - Messaging | Statistics .....145**



Messaging   Protocol Index .....	147
Messaging   Pass-Thru .....	151
Messaging   Diagnostics Messages .....	153
Digital I/O .....	156
Diagnostics .....	159
Energy Saving .....	163
HMI Settings .....	167
Device Settings .....	168
Device Settings   Device Info .....	169
Device Settings   Mounting .....	171
PackTrack™ Calibration Wizard .....	172
Device Settings   Options .....	173
Diagnostics .....	176
Diagnostics   Monitor .....	177
Diagnostics   Read Test .....	179
Diagnostics   Status Viewer .....	180
Utilities .....	183
Utilities   Backup or Restore .....	184
Utilities   Reboot .....	186
Utilities   Update Firmware .....	187
Utilities   Launch Genius .....	189
Utilities   Help .....	190
<b>BARCODE SCANNING FEATURES.....</b>	<b>191</b>
<b>First-time Startup .....</b>	<b>191</b>
Default Parameters .....	191
Check Operations Using Test Mode .....	192
<b>Basic Installation Procedures with the CBX510 .....</b>	<b>192</b>
<b>Basic Installation with SC5000 Controller .....</b>	<b>197</b>
<b>LED Indicators .....</b>	<b>202</b>
<b>Control Panel Buttons .....</b>	<b>203</b>
X-PRESS™ Human Machine Interface .....	203
X-PRESS Functions .....	203
Restore Button and Other Functions .....	206
<b>PackTrack™ .....</b>	<b>207</b>
Using the PackTrack Wizard .....	208
Top-Mounted Barcode Scanner Calibration Using PackTrack .....	212
Side-Mounted Barcode Scanner Calibration Using PackTrack .....	217
Bottom-Mounted Barcode Scanner Calibration Using PackTrack .....	223
Verifying PackTrack Calibration .....	223
<b>Replacing an Installed DS8110 .....</b>	<b>225</b>
Replacing a Standalone Scanner Using Restore .....	225
Replacing a Slave Scanner in an Array/Tunnel Automatically .....	226
Replacing a Slave Scanner in an Array/Tunnel Using Restore .....	227
Replacing a Master Scanner in an Array/Tunnel Using Restore .....	227
Checking the Operation of the Replacement .....	228
<b>Typical Layouts .....</b>	<b>228</b>
Large Synchronized Network Layout .....	229
<b>Advanced Code Reconstruction (ACR™) .....</b>	<b>232</b>
Tilt Angle for Advanced Code Reconstruction .....	232
Minimum Code Height for Advanced Code Reconstruction .....	233
<b>Reading Diagram .....</b>	<b>235</b>
<b>MAINTENANCE .....</b>	<b>246</b>
<b>Overview .....</b>	<b>246</b>
<b>Maintenance Tasks .....</b>	<b>247</b>
Cleaning the Exit Window .....	247
Cleaning the Photoelectric Sensor .....	248
Cleaning the Tachometer .....	249
Tighten Mounting Hardware .....	249
Checking Barcode Scanning System Connections .....	249
Verify Barcode Scanner Operation .....	250

## Contents

---

Verify Photoelectric Sensor Operation .....	250
Verify Tachometer Operation .....	250
<b>TROUBLESHOOTING .....</b>	<b>251</b>
LED Diagnostic Indication .....	252
Error Codes and Resolutions .....	253
<b>TECHNICAL FEATURES .....</b>	<b>260</b>
Technical Specifications .....	260
<b>INDEX .....</b>	<b>263</b>



# References

## Reference Documentation

The documentation related to the DS8110 management is listed below:

- CBX510 Connection Box Installation Manuals
- SC5000 Controller Manuals

## Support Through the Website

Datalogic provides several services as well as technical support through its website. Log on to [www.datalogic.com](http://www.datalogic.com).

For quick access, from the home page click on the search icon , and type in the name of the product you're looking for. This allows you access to download Data Sheets, Manuals, Software & Utilities, and Drawings.

Hover over the Support & Service menu for access to Services and Technical Support.

## Patents

See [www.patents.datalogic.com](http://www.patents.datalogic.com) for patent list.

This product is covered by one or more of the following patents:

Utility patents: EP0959426B9, EP1217571B1, EP2519856, JP4376353B2, US6177979, US6394352, US6443360, US6527184, US6742710, US9104928, US9230146, US9530037, US9625715



## Conventions

### NOTE



This symbol draws attention to details or procedures that may be useful in improving, maintaining, or enhancing the performance of the hardware or software being discussed.

### WARNING



This symbol identifies a hazard or procedure that, if incorrectly performed, could cause personal injury or result in equipment damage. It is also used to bring the user's attention to details that are considered **IMPORTANT**.

### HIGH VOLTAGE



This symbol alerts the user they are about to perform an action involving, either a dangerous level of voltage, or to warn against an action that could result in damage to devices or electrical shock.

### LASER CAUTION



This symbol alerts the user they are about to perform an action involving possible exposure to laser light radiation.

### ESD CAUTION



This symbol identifies a procedure that requires you take measures to prevent Electrostatic Discharge (ESD) e.g., use an ESD wrist strap. Circuit boards are most at risk. Please follow ESD procedures.



# Compliance

## Electrical Safety

This product conforms to the applicable requirements contained in the European Standard for electrical safety EN 60950 at the date of manufacture.

## Laser Safety

The following information is provided to comply with the rules imposed by international authorities and refers to the correct use of the DS8110 barcode scanners.

## Standard Regulations

These barcode scanners use low-power laser diodes. Avoid staring at the beam as one would with any very strong light source, such as the sun.

Take care when installing the laser device to avoid inadvertent laser beam contact with the eye of an observer, including through reflective surfaces.

This product conforms to the applicable requirements of IEC 60825-1 and complies with 21 CFR 1040.10 except for deviations pursuant to Laser Notice N° 50, date June 24, 2007. The scanner is classified as a Class 2 laser product according to IEC 60825-1 regulations.

There is a safety device which allows the laser to be switched on only if the motor is rotating above the threshold for its correct scanning speed.

LASER CAUTION



**Use of controls or adjustments or performance of procedures other than those specified herein may result in exposure to hazardous visible laser light**

## Bureau of Indian Standard (BIS)

Self Declaration – Conforming to IS 13252 (Part 1):2010, R-41009288.

## Warning and Serial labels

The Warning Label on the front of the barcode scanner indicates exposure to laser light and the device classification.



Produit(s) conforme selon 21CFR 1040.10 sauf des dérogations relatives à la Laser Notice N° 50, date Juin 24, 2007.

Dans le paquet il y a l'étiquette(s) pour les pays où le texte d'avertissement en français sont obligatoires. Le(s) mettre sur le produit à la place de la version anglaise.



LASER CAUTION



Disconnect the power supply when installing the device or during maintenance to avoid unintentional exposure to laser light.

WARNING



There are no user serviceable parts inside the barcode scanner. Service should only be performed by Datalogic trained and certified technicians.

Any violation of the optical parts in particular could result in exposure to Class 3B laser light.

## Power Supply

This product is intended to be installed by Qualified Personnel only.

This product is intended to be supplied by a UL listed or CSA Certified Power unit with “Class 2” or LPS power source.

## CSA Certified



## CE Compliance

CE marking states the compliance of the product with essential requirements listed in the applicable European directive. Since the directives and applicable standards are subject to continuous updates, and since Datalogic promptly adopts these updates, therefore the EU declaration of conformity is a living document. The EU declaration of conformity is available for competent authorities and customers through Datalogic commercial reference contacts. Since April 20th, 2016 the main European directives applicable to Datalogic products require inclusion of an adequate analysis and assessment of the risk(s). This evaluation was carried out in relation to the applicable points of the standards listed in the Declaration of Conformity. Datalogic products are mainly designed for integration purposes into more complex systems. For this reason it is under the responsibility of the system integrator to do a new risk assessment regarding the final installation.

WARNING



**This is a Class A product. In a domestic environment this product may cause radio interference in which case the user may be required to take adequate measures.**

## EAC Compliance

Customs Union:

The CU Conformity certification has been achieved; this allows the Product to bear the Eurasian Mark of conformity.

## FCC Compliance



Modifications or changes to this equipment without the expressed written approval of Datalogic could void the authority to use the equipment.

This device complies with PART 15 of the FCC Rules. Operation is subject to the following two conditions: (1) This device may not cause harmful interference, and (2) this device must accept any interference received, including interference which may cause undesired operation.

This equipment has been tested and found to comply with the limits for a Class A digital device, pursuant to part 15 of the FCC Rules. These limits are designed to provide reasonable protection against harmful interference when the equipment is operated in a commercial environment. This equipment generates, uses, and can radiate radio frequency energy and, if not installed and used in accordance with the instruction manual, may cause harmful interference to radio communications. Operation of this equipment in a residential area is likely to cause harmful interference in which case the user will be required to correct the interference at his/her own expense.





# Chapter 1

## Introduction

### Product Description

The DS8110 barcode scanner complete with decoder is designed to provide an innovative and high performance solution in omnidirectional reading applications by combining the following advanced technologies with Datalogic solid experience in the material handling sector.

Some of the main features of the DS8110 are listed below:

- Scanning speed 1000 scans/sec
- Reads all popular codes
- Supply voltage from 20 to 30 vdc
- Test mode to verify the reading features and exact positioning of the scanner without the need for external tools
- Programmable in several different operating modes to suit the most various barcode reading system requirements
- Light source: solid state laser diodes; the light emitted has a wave length between 630~680 nm. For laser safety precautions refer to the “compliance” section at the beginning of this manual



# General View



- ① HMI and LEDs
- ② Scanner Exit Window
- ③ I/O
- ④ Ethernet 2
- ⑤ Serial Label
- ⑥ Caution Labels
- ⑦ Power
- ⑧ Ethernet 1
- ⑨ Mounting Holes
- ⑩ Void Warranty Sticker
- ⑪ Void Warranty Sticker

## Applications

The DS8110 barcode scanners are specifically designed for industrial applications and for all cases requiring high reading performance such as:

- Code reconstruction (ACR™)
- Reading of codes covered by plastic film
- Reading of codes with a wide depth of field
- Reading codes within a wide field of view
- Reading of high resolution codes positioned at long distances from the reader
- Code reading on fast moving objects

These barcode scanners are designed for both single-reader layouts and multi-reader layouts. For typical layouts, see *section “Typical Connection Block Diagrams” on page 23*.

FEATURE	BENEFIT
DST	Digital Signal Technology converts analog signals to digital before processing for much improved decoding capability especially on poorly printed or damaged codes.
ACR™	Fifth generation Advanced Code Reconstruction technology allows the reading of low aspect ratio labels placed anywhere on a parcel and enhances the readability of poorly printed or damaged codes.
PACKTRACK™	Second generation Datalogic patented parcel tracking system which improves the reading features in omnidirectional stations. In particular, PackTrack manages 6-sided reading systems when it is impossible to detect the real position of the code on the parcel, thus overcoming the need for external accessories essential in traditional tracking systems.
ASTRA™	Third generation Automatically SwITched Reading Area is the Datalogic technology based on a multi-laser architecture and a fixed mounted optic system which concentrates the multiple laser emissions in a single laser beam. As each laser emitter is focused on a specific range of the reading area, a sophisticated electronic controller selects the best focused laser emitter with respect to the code to read. This allows the reading of medium-high density codes in a large reading area on very fast conveyors.
Flexibility	The high frequency laser diode modulation system guarantees complete immunity to ambient light and allows installation of the DS8110 in any working area.
Reading parcels on conveyors	As a result of the ASTRA multiple laser technology, DX8210 and DS8110 give a great real time DOF even on high speed conveyors. Furthermore, DX8210 and DS8110 implement the PackTrack functionality which leads to an increase of the plant production as a result of the augmented system throughput.
EBC	Ethernet Based Connectivity is a reliable real-time network communication between scanners in a reading station tunnel or array.
e-Genius	<b>e-Genius</b> is a browser-based User Interface with the following characteristics: No software to install; Multilanguage platform; All the configuration parameters stored in the scanner; Not dependent on the Physical interface; Remote access through local network.
Energy Saving	A software parameter group which allows management of the energy saving feature. In particular, it allows turning on/off the motor and laser of all network scanners according to the selected digital input, encoder, or communication channel. The time required to restart the system is less than 1 minute independently from the number of scanners connected. It is suggested to use this parameter for example when the conveyor is stopped for a lengthy period.

## Model Description

The DS8110 barcode scanner is available in versions that differ depending on the interface connection, the optical resolution and the optic version:

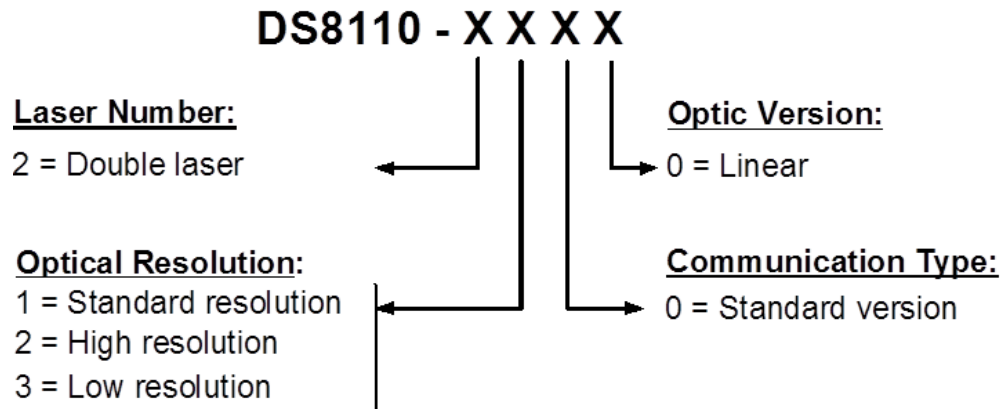

## DS8110 versions

Model	Description	Part Number
DS8110-2100	Standard Resolution	932500001
DS8110-2200	High Resolution	932500002
DS8110-2300	Low Resolution	932500005

## X-PRESS (Human Machine Interface)

The DS8110 barcode scanner includes two external buttons that make up the X-PRESS HMI interface and perform specific tasks without the need of connecting to e-Genius. See for functional description:



Some of these functions may be performed using e-Genius. See Chapter .

## Accessories

The following accessories are available on request for the DS8110 barcode scanner.

Category	Description	Part Number
Cables and Terminators		
Ethernet Cables	ETH CABLE M12-M12 1M (straight-straight) Scanner to Scanner EBC (ETH1 or ETH2)	93A050065
	ETH CABLE M12-M12 3M (straight-straight) Scanner to Scanner EBC (ETH1 or ETH2)	93A050066
	ETH CABLE M12-M12 5M (straight-straight) Scanner to Scanner EBC (ETH1 or ETH2)	93A050067
	ETH CABLE M12-M12 1M (straight- 90°) SC5000 to Scanner EBC (ETH1 or ETH2)	93A050068
	ETH CABLE M12-M12 3M (straight- 90°) SC5000 to Scanner EBC (ETH1 or ETH2)	93A050069
	ETH CABLE M12-M12 5M (straight- 90°) SC5000 to Scanner EBC (ETH1 or ETH2)	93A050070
	ETH CABLE M12-RJ45 5M (90° -RJ45) SC5000 to the Host or Configuration PC (HOST or CFG)	93A050088
	CAB-ETH-M01 M12-IP67 1M (straight- RJ45) Scanner to the Host or Configuration PC	93A051346
	CAB-ETH-M03 M12-IP67 3M (straight- RJ45) Scanner to the Host or Configuration PC	93A051347
	CAB-ETH-M05 M12-IP67 5M (straight- RJ45) Scanner to the Host or Configuration PC	93A051348
REDs Cables	ETH CABLE M12-M12 1M (90° - 90°) SC5000 to SC5000 EBC (ETH1 or ETH2)	93A050087
	REDS POWER ALARM CABLE 5M PWR-480B to CBX510 power alarm connections	93A050086
EBC Patch Cable	ETH CABLE M12-M12 0.5M (straight-straight) Female to Female EBC patch cable; close the EBC when a scanner is sent to repair, only for Master/Slave	93A050085
Interface Cable	SC5000 to CBX510 for Serial or I/O connections	93A050071
CBX Cables	CAB-DS01-S M12-IP67 1M Scanner to CBX for Serial or I/O connections	93A050058
	CAB-DS03-S M12-IP67 3M Scanner to CBX for Serial or I/O connections	93A050059
	CAB-DS05-S M12-IP67 5M Scanner to CBX for Serial or I/O connections	93A050060
AS-I Terminal	AS-I CABLE TERMINAL for AS-I branch topology wiring	93ACC0083
Power Cables	PWR CABLE, AS-I, 2 Wires, 10M (Backbone with caps)	93ACC0081
	PWR CABLE, AS-I, 2 Wires, 25M (Backbone with caps)	93ACC0082
	PWR CABLE M12- ASI standard 1M (Node)	93ACC0067
	PWR CABLE M12- ASI standard 2M (Node)	93ACC0068
	PWR CABLE ext. M12 Male-M12 Fem 3M for PG-240	93ACC0149
	PWR CABLE ext. M12 Male-M12 Fem 5M for PG-240	93ACC0150
	PWR CABLE, CAB-LP-05 M12 Female-Free Wires 5M for alternative power connections	93A050037

Category	Description	Part Number
<b>Connection Boxes</b>		
	CBX100 Compact	93A301067
	CBX100 Compact All in One (includes BM100)	93A301076
	CBX510 Modular	93A301087
	CBX510 Modular All in One (includes BM100) + BA200	93A301091
Backup Module	BM100 Backup Module	93ACC1808
Mounting Hardware	BA200 Mounting Adapters (to Bosch or 80/20 Frames)	93ACC1822
Fieldbus Modules	BM300/310 Profibus Module STD/IP65	93ACC1810, 93ACC1811
Fieldbus Modules	BM700/710 Profinet Module STD/IP65	93ACC1816, 93ACC1886
<b>Controllers</b>		
	SC5000-1000 Standard System Controller	935750001
	SC5000-1100 Profibus System Controller	935750002
	SC5000-1200 Profinet System Controller	935750003
Mounting Hardware	BA200 Mounting Adapters (to Bosch or 80/20 Frames)	93ACC1822
<b>Mirrors</b>		
	GFC-8110 Close Distance Mirror	93A251034
<b>Power Supplies</b>		
	PG-100-K03 POWER SUPPLY 60W KIT (US) w/ M12 cable	93ACC0058
	PG-100-K01 POWER SUPPLY 60W KIT (EU) w/ M12 cable	93ACC0059
	PG-100-K02 POWER SUPPLY 60W KIT (UK) w/ M12 cable	93ACC0060
	PG-240-K03 POWER SUPPLY 240W 8 Port M12 (US) w/o M12 Cable	93ACC0144
	PG-240-K01 POWER SUPPLY 240W 8 Port M12 (EU) w/o M12 Cable	93ACC0145
	PWR-480B POWER UNIT 110/230VAC 24V	93ACC0076
<b>Sensors</b>		
	MEP-593 PHOTOCCELL KIT PNP (PH-1) with Free Wires	93ACC1791
	MEP-604 PHOTOCCELL KIT PNP M12-M12 Photocell with M12 connector for SC5000	93ACC0140
<b>Encoders</b>		
	OEK-2 OPTICAL ENCODER KIT (CAB 10M +SPRING)	93ACC1770
	OEK-4 ENC KIT PNP 250PPR + M12-M12 CABLE	95B082040
	OEK-4 ENC KIT PNP 250PPR + M12-FREE CABLE	95B082050
Field Mount Con- nectors	FMC-5000 2xM12 TRIG+ENC INPUT KIT Connectors for PLC signal to SC5000 (Tilt-Tray or Cross-Belt applications)	93ACC0181
<b>Mounting Brackets</b>		
L-Bracket	DS8110 L-shape Mounting Bracket	93ACC0080
<b>Miscellaneous</b>		
Air Cleaning System	ACS-DS8110 Air Cleaning System for DS8110	93ACC0084



## Photoelectric Sensor

The optional Datalogic Photoelectric Sensor is used in DS8110 barcode scanner systems to detect the presence of an item in the scanning area.

The photoelectric sensor is used in singulated systems where the packages are separated by an open space between the trailing edge of one package and the leading edge of the next. The photoelectric sensor, along with the encoder, enables a programmable transmit point at a defined distance from the sensor. Without the photoelectric sensor, the barcode scanner can be run in continuous mode. See *Modify Settings / Global Settings / Operating Mode*.

Depending on the application, these devices may need to be configured differently. While the photoelectric sensor and tachometer work well with belt conveyors, a special configuration is needed for tilt-tray and cross-belt sorter applications. See *section for wiring options*.



### Photoelectric Sensor and Cable (recommended)

MEP-593 PHOTOCCELL KIT	PNP (PH-1) with Stripped Wires	93ACC1791
MEP-604 PHOTOCCELL KIT	PNP M12-M12 Photocell with M12 connector for SC5000	93ACC0140



## Encoder (Tachometer)

The tachometer provides a continuous pulse to the system, which provides feedback on conveyor speed and transmit point, and can be used to help track the package position along the length of the conveyor. *See section for wiring options.*



### Encoder (Tachometer)

OEK-2 ENCOD KIT	OEK-2 ENC KIT (CAB 10m +SPRING)	93ACC1770
OEK-4 ENCOD KIT	OEK-4 ENC KIT PNP 250PPR + M12-M12 CABLE	95B082040
OEK-4 ENCOD KIT	OEK-4 ENC KIT PNP 250PPR + M12-FREE CABLE	95B082050

## Encoder/Tachometer Step Settings

The following table shows the **Encoder Step** setting used based on pulses per revolution. The Encoder Step setting is entered in **e-Genius** (*see section **Modify Settings** | **Global Settings** | **Operating Mode - Encoder Step** (hundredths of millimeter)*).

Encoder Model	PPR (Pulses Per Revolution)	PPI (Pulses Per Inch)	Encoder Step Setting
OEK-4 (Datalogic)	250	20	63
OEK-2 (Photocraft)	24	2	635
OEK-2	48	4	317
OEK-2	192	16	79
OEK-2	240	20	63



This symbol draws attention to details or procedures that may be useful in improving, maintaining, or enhancing the performance of the hardware or software being discussed.

## Photocraft Encoder/Tachometer Switch Setting



PPR	Setting
24	▲▲▼▼▲ 1 2 3 4 5
48	▼▼▼▲▲▲ 1 2 3 4 5
192	▲▲▲▼▼ 1 2 3 4 5
240	▼▼▲▲▼ 1 2 3 4 5



**NOTE** Only switches 1-5 are used to set the PPR (Pulses Per Revolution). Switches 6-8 are used for PNP/NPN settings as shown in the label on the arm of the encoder.

## CBX Industrial Connection Box

CBX Series are industrial connection boxes that can be used to connect the bar-code scanners to an encoder/tachometer, photoelectric sensor, serial devices, relays, or other peripherals. The CBX510 includes a BM100 backup module, which allows easy parameter restore and backup operations. The backup module also provides an easy way to upload existing parameters to a replacement bar-code scanner when necessary. See section for wiring options.



**Scanner operation requires a CBX510 connection box or SC5000 controller.**

### Industrial Connection Box

CBX510 Connection Box	CBX510 for DS8110 and DX8210	93A301087
CBX510 Connection Box	CBX510 ALL IN ONE+BA200	93A301091

## SC5000 System Controller

The SC5000 Controller offers all the necessary functions to make the phases of installation, setup, testing, and maintenance of the omni-directional reading array or tunnel easy and quick.

The SC5000 Controller is fully compatible with DS8110 and DX8210 scanners and its sturdy mechanical structure makes the SC5000 Controller the ideal solution for industrial environments. The Controller allows connection to the Trigger and Encoder/Tachometer. PNP inputs are available via M12 circular connectors, placed on the lower front panel (*see section* ).



### System Controller

SC5000-1000 System Controller	Standard	935750001
SC5000-1100 System Controller	Profibus	935750002
SC5000-1200 System Controller	Profinet	935750003



## Chapter 2 Mechanical Installation

HIGH VOLTAGE



Electrical Installation by Qualified Service Technicians Only! Procedures may involve exposure to high-voltage. A trained and authorized technician must perform these procedures. Do not attempt to perform any electrical installation procedures unless you are a trained technician.

ESD CAUTION



DS8110 barcode scanners contain electronics that may be affected by electrostatic discharge (ESD). To prevent personal injury or damage to the unit, please follow the safety precautions and warnings found in the References section at the beginning of this manual. Failure to follow these precautions may void your warranty.

### Preparing for Mechanical Installation

WARNING



Application-specific drawings and documents provided by Datalogic supersede any contradictory content in this manual.

Before mounting any components, please do the following:

- Read all instructions before beginning your installation.
- Define and confirm the accuracy of your application's requirements and structure position, especially the height of the conveyor from the floor.
- Review all installation-specific drawings provided with your equipment.
- Review and plan the mechanical installation of all devices used in your application. Be sure to allow adequate clearance for maintenance.
- Review and plan the power requirements for your application.
- Check the contents of the shipping cartons against the packing list.
- Record all product serial numbers.

NOTE



Refer to the Chapter Electrical Installation and Reference Documentation for details on connecting your barcode scanners to other devices in the system.

WARNING



When installing several scanners, take care to position them so that no laser beam enters the reading window of other scanners. This condition could occur more frequently for side mounted applications. If these precautions are not followed, read rate could be negatively affected. To resolve this problem, it is sufficient to slightly change the inclination and position of one of the two scanners involved if possible.

## Unpacking Instructions

Verify that the DS8110 barcode scanners and all the parts supplied with the equipment are present and intact when opening the packaging; the list of parts includes:

- DS8110 reader
- L-bracket
- Mounting screws (two types) and washers
- Barcode Test Chart



## Installation Sequence



Everything should be **MECHANICALLY INSTALLED** before performing any **ELECTRICAL INSTALLATION**.

See Chapter XX Electrical Installation for electrical installation details.

To complete mechanical installation and setup, you must:

1. Review the details of your application's requirements
2. Erect mounting structure or other supporting structures
3. Determine and mark the Mounting Bracket location(s)
4. Mount the bracket to the mounting structure
5. Mount the DS8110 to its mounting bracket
6. Mount the photoelectric sensor to the mounting structure (optional)
7. Mount the tachometer to the mounting structure (optional)
8. Mount the CBX connection box to the mounting structure
9. Mount the SC5000 to the mounting structure

10. Complete electrical installation (*See Chapter*)
11. Align the DS8110 for proper operation
12. Configure the DS8110 (*See Chapter*)
13. Check DS8110 operations (*See Chapter*)

## What You Need to Know About Your Application

To assure you get optimal performance out of your DS8110, it must be installed to meet the complete needs of your application. Therefore, take the time to learn the details of your application. The better you know your application, the easier it is to apply the DS8110's capabilities to meet your application's requirements.

Below is what you will need to know before you can begin installation:

- Conveyor Specifications
  - Conveyor type: Belt, tilt-tray, cross belt, other?
  - What is the conveyor width?
  - What is the conveyor speed?
  - Does conveyor speed vary or is it constant?
- Product Specifications
  - Are the packages being transported always singulated (not touching) or non-singulated (possibly touching)?
  - How many different product sizes may be involved?
  - Are products justified: toward/away from reader, centered, or variable?
- Application Specifications
  - How will the barcode information be used in your application?
  - What are your communication requirements?

While it is nearly impossible to cover all application configurations, the next several pages provide the basics on determining how to mechanically install your DS8110. If you need additional assistance, feel free to contact your sales representative or customer service ([www.datalogic.com](http://www.datalogic.com)).



# Installation

## Dimensions and Clearances

The overall dimensions of the DS8110 are 216 x 96 x 127 mm (8.5 x 3.8 x 5 in.).

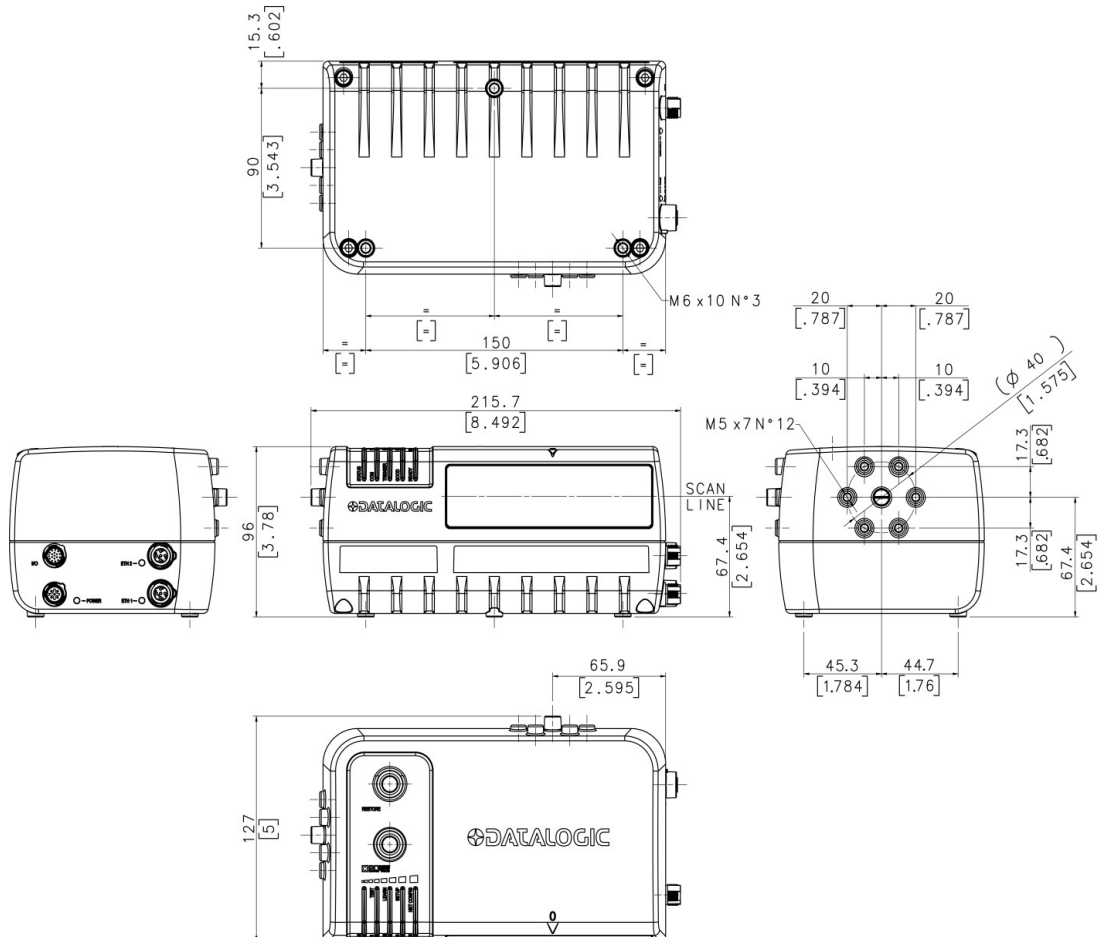

**The DS8110 is a sealed, unventilated unit. Mounting the unit with 300mm [12"] of clearance (front, top, and sides) is recommended for cooling and ease of maintenance.**

## Physical Support Requirements

For details on the weight of the barcode scanners, see *Chapter 8, Technical Features*. Multiple-head systems may include further details on the physical support requirements with any application-specific documentation provided.

## Vibration Limitations

See *"Technical Features"* on page 260.



---

## General Mounting Guidelines

It is important that you follow these general precautions when installing, setting up, operating, maintaining, troubleshooting, or replacing any Datalogic products, parts or related equipment.

As you plan and install your DS8110 barcode scanning system application, be sure to keep the following guidelines in mind:

- All mounting structure assembly and equipment installation can be performed by one installer.
- Determine the proper orientation and position of the barcode scanner.
- Leave adequate clearances (approximately 300 mm [12 inches]) for wiring.
- Route wires carefully to reduce or minimize electrical noise. When power and communication wiring must cross, make their intersection perpendicular.
- Proper grounding limits the effects of noise due to Electromagnetic Interference (EMI).

## Mounting Structure Considerations

Your first task is to mount your DS8110 barcode scanner. You can provide your own mounting structure or Datalogic can design one for you. We recommend using a Datalogic mounting structure for standard applications.

Your mounting structure must provide the following capabilities:

- It is adjustable enough for you to move your unit to the optimum position for proper scanning.
- It allows a technician access to the barcode scanner while it is mounted.
- It must be as vibration free as possible so as not to affect the scanning accuracy.
- It is constructed of steel or aluminum.
- It provides approximately 300 mm [12 inches] minimum clearance on all sides. This clearance is necessary to provide proper ventilation, allow access to all panels of the barcode scanner, and allow room for proper servicing.

## Mounting the Scanner

The DS8110 can be installed to operate in any position. There are 12 screw holes (M6 X 8) on the sides of the scanner for mounting. The diagram below can be used for installation; refer to reading diagrams (See ) and any application drawings for correct positioning of the scanner with respect to the reading zone and scanner orientation.

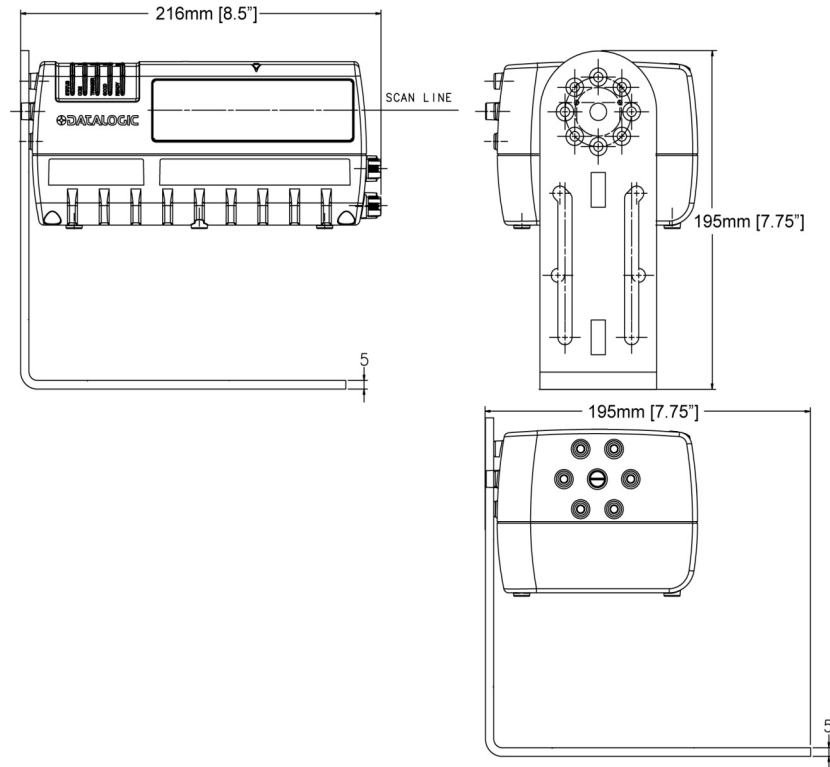

The L-bracket included with the DS8110 scanner allows it to be installed in the most suitable position for your application. The L-bracket is mounted to the scanner as shown below:

### Preferred Mounting Using Countersunk Screws

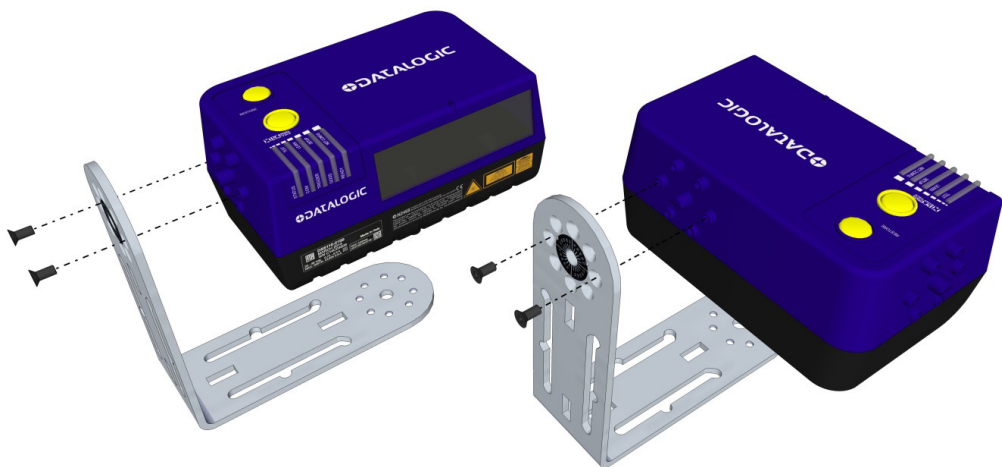

In order to guarantee a laser line position tolerance of 1.5 cm [0.06 in], tighten the two mounting screws a little at a time, alternating between them, and without applying torque to the scanner. This allows the screws to seat properly into the countersunk holes.

## Alternative Mounting Using Cap Screws and Washers

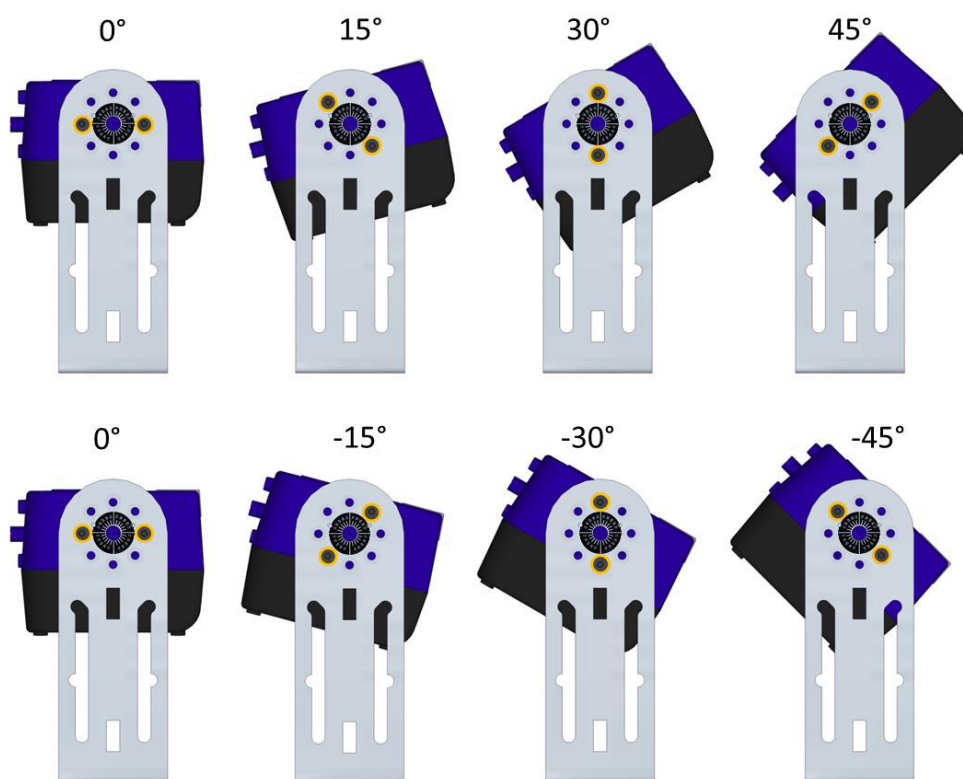
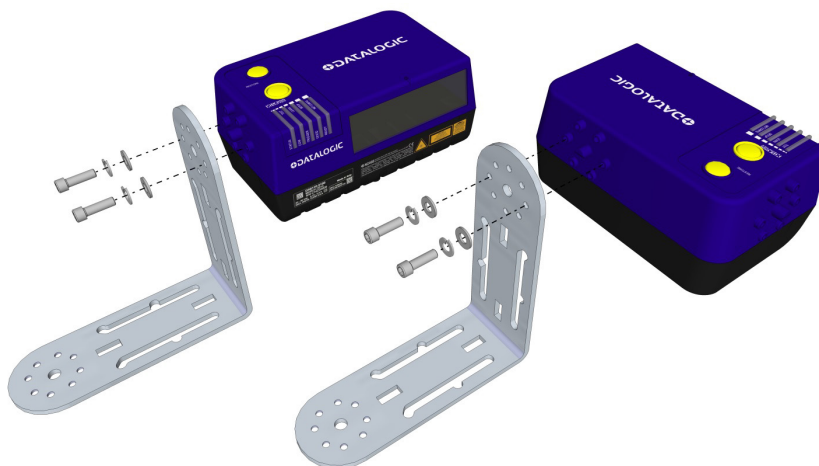

If the DS8110 needs to be mounted at a 5-degree angle or within 5-degrees of the angles shown in (+/- 5, +/-25, or +/-35-degrees), mount it to the opposite end of the L bracket as shown below:

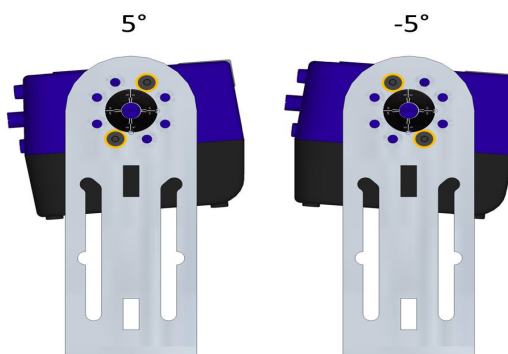

## Positioning the Scanners

The DS8110 barcode scanners are able to decode barcode labels at a variety of angles; however significant angular distortion may degrade reading performance.

When mounting the scanners, take into consideration these three ideal label position angles: Pitch 0°, Skew 0° to 45° and Tilt 0°.

Follow the suggestions for the best orientation:

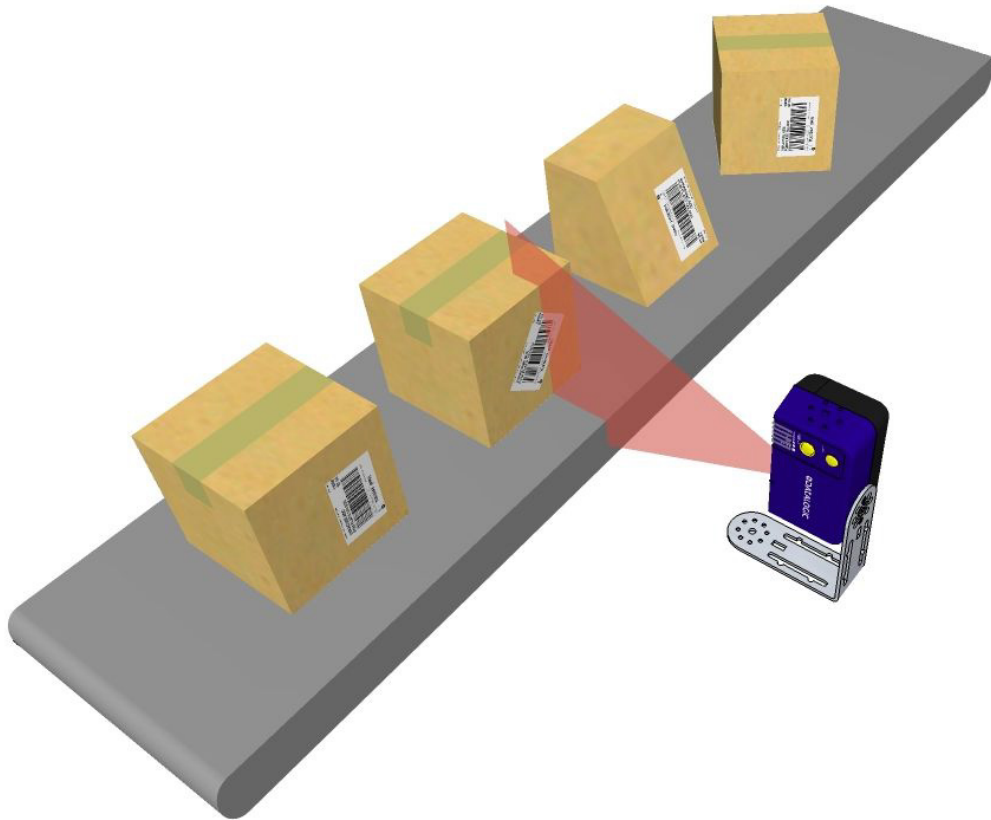



## Chapter 3

# Electrical Installation

HIGH VOLTAGE



Electrical Installation by Qualified Service Technicians Only! Procedures may involve exposure to high-voltage. A trained and authorized technician must perform these procedures. Do not attempt to perform any electrical installation procedures unless you are a trained technician.

ESD CAUTION



The DS8110 barcode scanners contain electronics that may be affected by electrostatic discharge (ESD). To prevent personal injury or damage to the unit, please follow the safety precautions and warnings found in the References section at the beginning of this manual. Failure to follow these precautions may void your warranty.

## Preparing for Electrical Installation

Before mounting any components, please do the following:

- Read all instructions before beginning your installation.
- Observe all electrical safety requirements discussed in the Introduction to this manual.
- Define and confirm the accuracy of your application's requirements.
- Review all installation-specific drawings.
- Review and plan the power requirements for your application.
- Review and plan the communications requirements for your application.

WARNING



The content of this manual may be superseded by any customer-specific documentation provided by Datalogic. Before proceeding with any installation procedures, be sure to review ALL documentation, especially content that contains details specific to your installation.



**Everything should be MECHANICALLY INSTALLED before performing any ELECTRICAL INSTALLATION. See Chapter for mechanical installation details.**

Most DS8110 applications are shipped with the CBX connection box and all the necessary cabling required to electrically install the system. If your system requires custom-length cables or other special wiring, documentation specific to these requirements has been provided in your shipment. This special documentation supersedes any contradictory content in this manual.

**To reduce the possibility of damage to the unit, check all cabling between the scanner and other devices for accuracy.**

## Connecting a DS8110 Scanner

To install a DS8110 barcode scanner, follow this sequence:

- Complete mechanical installation (*See Chapter .*)
- Complete electrical installation (*See wiring illustrations provided in this chapter.*)
- Observe all electrical safety requirements outlined in this chapter.
- Ground the mounting structure to protective earth (PE) ground.
- If used, wire the photoelectric sensor (or other trigger) to the CBX510 connection box/SC5000.
- Wire the tachometer to the CBX510 connection box/SC5000 (if used).
- Wire serial ports to the CBX510 connection box/SC5000 if needed.
- Connect the M12 end of the Ethernet cable to the scanner's HOST port and network switch as required by your application.
- Connect the scanner to its power supply.
- Connect the power supply to the power source.
- Setup / check scanner operations (*See Chapter .*)

# Typical Connection Block Diagrams

## Single DS8110 Barcode Scanner to CBX510

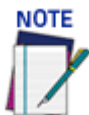
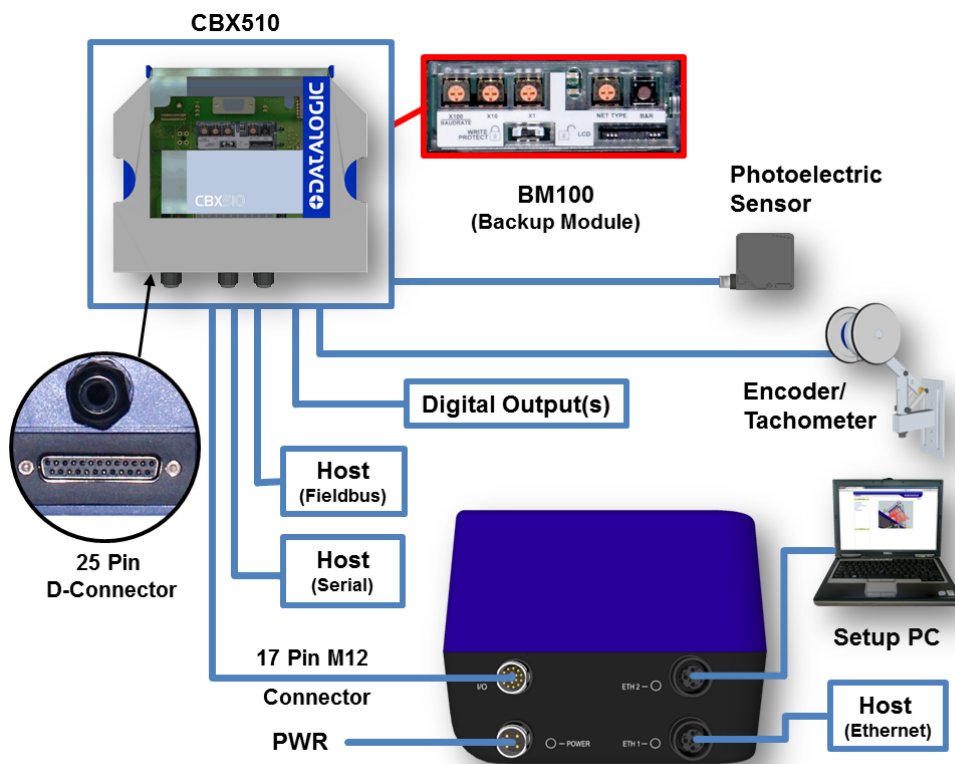

The BM100 switches indicated below must be set to 0 (zero), and the connector indicated is not supported.

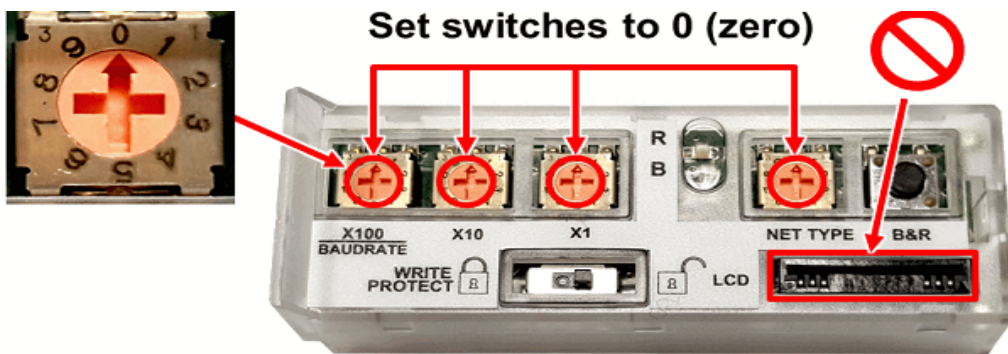



## Master/Slave Array with CBX510

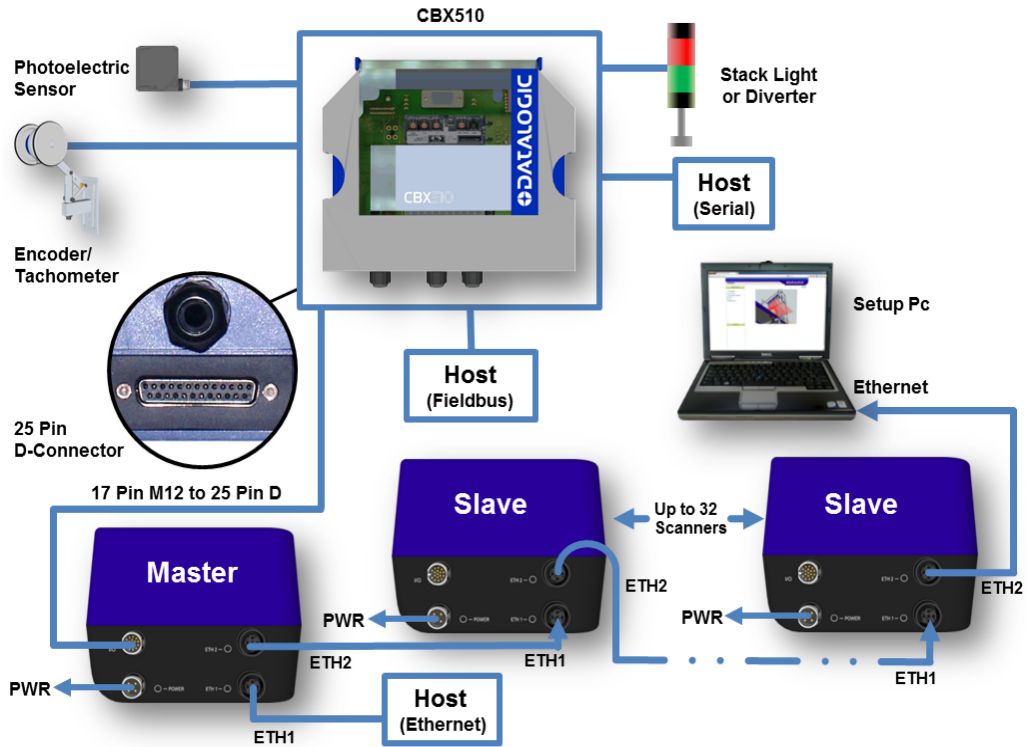

The BM100 switches indicated below must be set to 0 (zero), and the connector indicated is not supported.

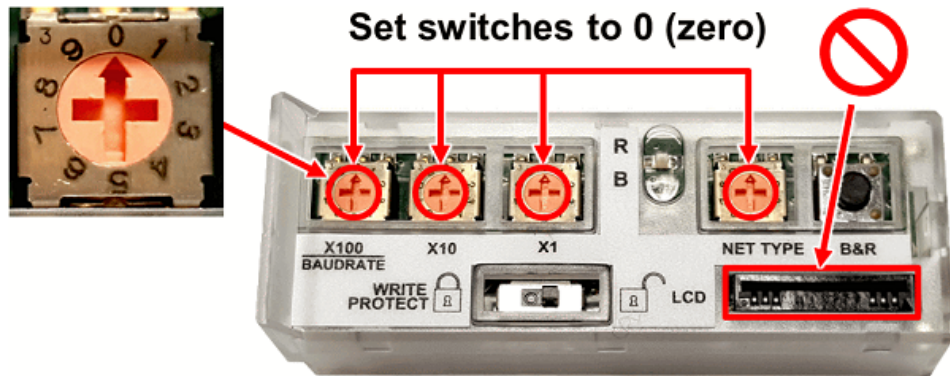

## DS8110 Barcode Scanners in an Array with SC5000 Master

In an array (tunnel) using the SC5000 Controller, the chain of scanners completes a circle from and to the SC5000 Controller via ETH1 and ETH2. In this scenario, if one scanner fails, communication from the other scanners to the SC5000 Controller is not interrupted.



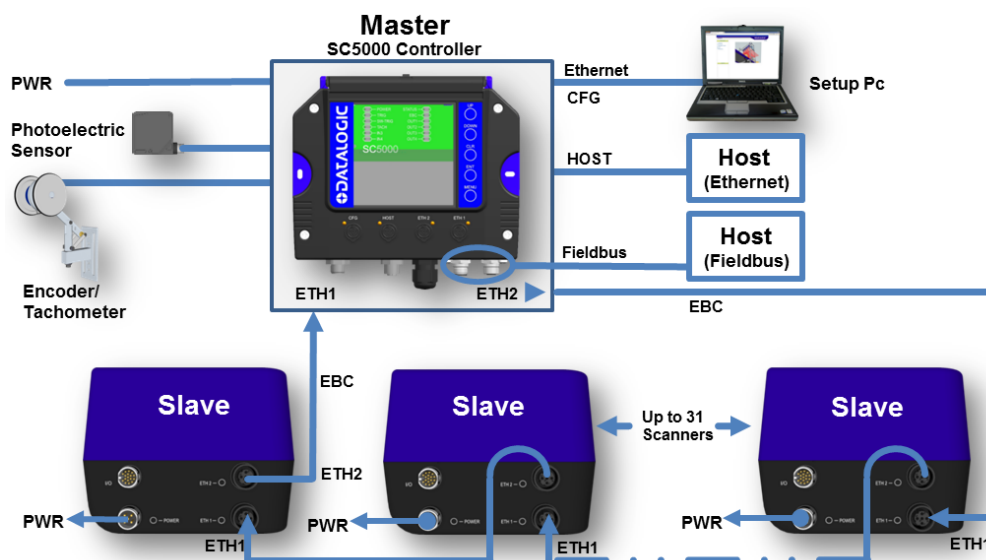

When using the SC5000, a Fieldbus Host only connects to the SC5000 Fieldbus model (Profinet or Profibus) at the connectors shown. It cannot connect to the CBX.

An **Ethernet Host** connects to the **HOST** connector on the SC5000 top cover. A **Serial Host** must connect through the CBX (see )

## General Electrical Installation Guidelines

It is important that you follow these general precautions when installing, setting up, operating, maintaining, troubleshooting or replacing any Datalogic products, parts or related equipment.

As you plan and install your scanner(s), be sure to keep the following guidelines in mind:

- Determine the scanner is in the proper location as outlined in Chapter 2.
- Leave adequate clearances (approximately 300mm [12 inches]) for wiring.
- Route wires carefully to reduce or minimize electrical noise.

### WARNING



When planning your installation wiring, remember all power connections must be quick-disconnect. For **PERMANENTLY CONNECTED EQUIPMENT** a readily accessible disconnect device must be incorporated in the building installation wiring. For **PLUG-GABLE EQUIPMENT** the socket-outlet must be installed near the equipment and must be easily accessible.

To assure no ESD damage will occur, be sure to observe the precautions outlined in the Introduction to this manual.

Ground the mounting structure to safety ground (protective earth ground (PE)). See wiring recommendations for safety ground.

## DS8110 Connector Panels

After completing mechanical installation, use this section to properly wire your scanners for optimal performance in your application. DS8110 wiring connections are made to the connector panel and through the CBX connection box (connected to the I/O port of the scanner). In most applications, the cable connections to the scanner will include:

1. I/O (Connects directly to the 25-pin D type connector on the CBX connection box)
2. POWER
3. ETH 2 (Setup or EBC scanner network, default IP Address: 192.168.3.100)
4. ETH 1 (Host or EBC scanner network, default IP Address: 172.27.101.220)



Route wiring from the scanner's connector panel through the wiring channels (if available) on the Datalogic mounting structure when interconnecting cables to other devices.



## Connecting a PC to the DS8110

During initial setup, a PC (laptop) may be connected to the DS8110 with a M12 to RJ45 cable. Screw the M12 connector to the ETH 2 port of the scanner and plug the RJ45 into the Ethernet port of your PC. If the ETH 2 port is in use, ETH 1 port can be used. For information on connecting to e-Genius, see *Chapter*.



**ETH2** is the **Setup** port, **ETH1** is the **HOST** port.

A laptop can only communicate to a scanner that is connected to a **CBX Connection Box** or **SC5000 Controller**.

Parameters for tunnel are set up in **MASTER** scanner (or **SC5000 Controller**) only.

## Power Connector Pin-Out Table

A recommended power supply and cabling is available with the DS8110 and DX8210 (and SC5000 Controller). However, if your installation requires custom power supply wiring, the pin-outs of the unit power connector are provided below for your convenience.

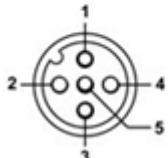
24V --- 4A MAX		POWER Input	
		Unit Connector (shown)	Mating cable connector
		5-PIN M12-TYPE MALE	5-PIN M12-TYPE FEMALE
MALE 5-PIN M12-TYPE		Pin	Function
		1	+24 VDC
		2	n/c
		3	dc return
		4	n/c
		5	protective earth (chassis)



When using a DS8110 barcode scanner, no power supply is required for the CBX510 connection box. All power and some communication options are fed to the CBX510 through the scanner's 17-pin I/O connector to the CBX510 25-pin connector using the cable provided.

In cases where the AS-I cabling is not used, the alternative CAB-LP-05 cable can be used to connect the power supply to the scanner. Connect the Brown/White pair to +24 Vdc and the Blue/Black pair to 0 V- (GND).

## Power Connections

**WARNING**



When planning your installation wiring, remember all power connections must be quick-disconnect.

The socket-outlet must be installed near the scanner. The outlet must be a readily accessible disconnect device.

**HIGH VOLTAGE**



While performing the following wiring connection procedures, be sure to follow all safety procedures regarding high-voltage as outlined in the Introduction to this manual. No power should be applied to any device until all wiring is completed and checked for accuracy.

**IMPORTANT**



Ground the scanner to safety ground (protective earth ground (PE)). See wiring recommendations for safety ground.

The CBX connection boxes provide flexible connectivity to a range of I/O devices as well as serial hosting. The DS8110 connects to the CBX via its I/O port using a single 17-pin M12 to 25-pin D cable. The CBX connection box also provides space for an optional BM100 backup module (recommended) for parameter storage, allowing quick replacement and configuration of the scanners.

In a system with multiple scanners and other devices required in a scanning array (tunnel), an SC5000 Controller serves as the system Master and provides communications between devices and to the Host. Complete installation information for the SC5000 Controller is available in the *SC5000 System Controller Reference Manual* available at [www.datalogic.com](http://www.datalogic.com).

## CBX510 Connection Box

Complete installation information for the connection box is available in the CBX510 Installation Manual available at [www.datalogic.com](http://www.datalogic.com). A simple drawing of the interior of the box is shown below.

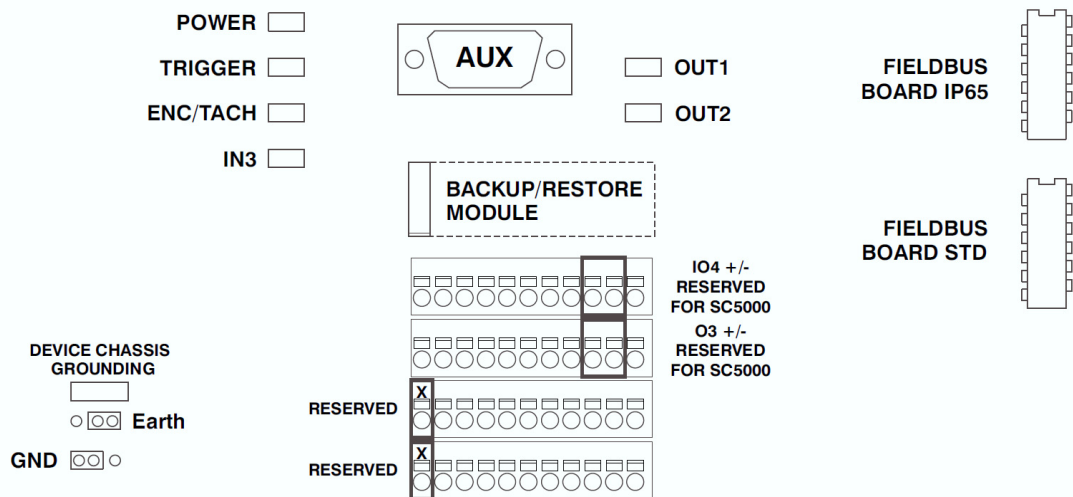

## Wiring Into the CBX510 Connection Box

**WARNING**



**DO NOT** connect a separate power source to the CBX510 connection box. The CBX510 receives its power through its connection to the DS8110/DX8210 Barcode Scanner. Connecting a separate power source will be detrimental to the system operation.

**DISCONNECT POWER** from the scanning system and CBX510 before wiring any components.

Loose-lead cables must pass through the water-tight seals in the base of the CBX510 connection box. Insert the cables allowing enough slack for the individual wires to reach the appropriate pin block connectors. Securely tighten the water-tight seals after the cables have been inserted.

Insulation on individual wires should be removed to expose 13 mm [0.5 inch] of bare metal before inserting into the pin block.

## Main Serial Interface

The optocoupled main serial interface is compatible with the following electrical standards:

- RS232
- RS422 full-duplex

### RS232 Interface

The main serial interface is used for communication with the Host computer and allows transmission of code data.

It is always advisable to use shielded cables. The overall maximum cable length must be less than 15 m (49.2 ft).

The following positions of the CBX510 spring clamp connector (row 4) are used for RS232 interface connection:

### RS232 Interface

The main serial interface is used for communication with the Host computer and allows transmission of code data.

It is always advisable to use shielded cables. The overall maximum cable length must be less than 15 m (49.2 ft).

The following positions of the CBX510 spring clamp connector (row 4) are used for RS232 interface connection:

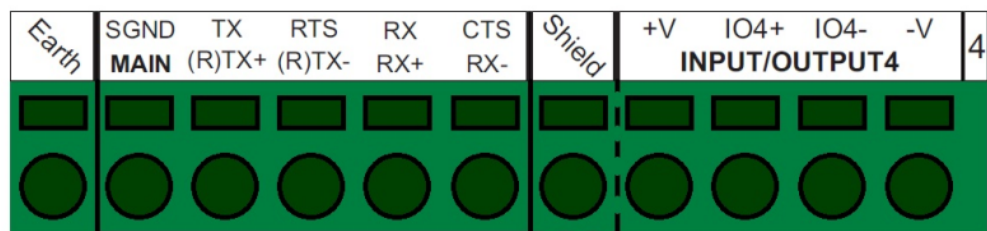

Name	Function
SGND	Signal ground (isolated)
TX	Transmit
RTS	Request to send
RX	Receive
CTS	Clear to send

As suggested above, the cable shield should be connected in the 'Shield' position.

The RTS and CTS signals control data transmission and synchronize the connected devices. If the RTS/CTS hardware protocol is enabled, the scanner activates the RTS output to indicate a message can be transmitted. The Host must activate the CTS input to enable the transmission.

#### WARNING



RTS/CTS lines should only be connected if the Main serial port handshaking is configured for **Hardware (RTS/CTS)** (see section ).

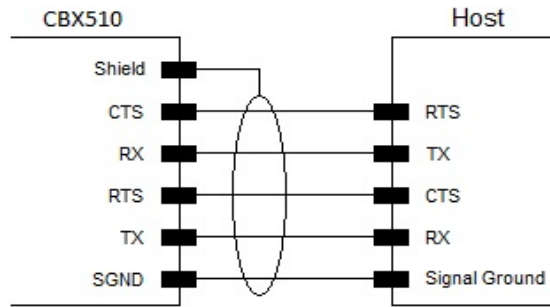

## RS422 Full-Duplex Interface

The RS422 full-duplex interface is used for non-pollled communication protocols in point-to-point connections over longer distances (max 1200 m / 3940 ft) than those acceptable for RS232 communications or in electrically noisy environments.

The following positions of the CBX510 spring clamp connector (row 4) are used for RS422 full-duplex interface connection:

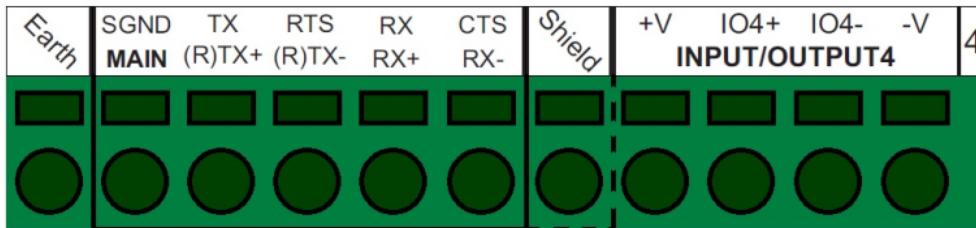

Name	Function
SGND	Signal ground (isolated)
TX+	RS422 output (+)
TX-	RS422 output (-)
RX+	RS422 input (+)
RX-	RS422 input (-)

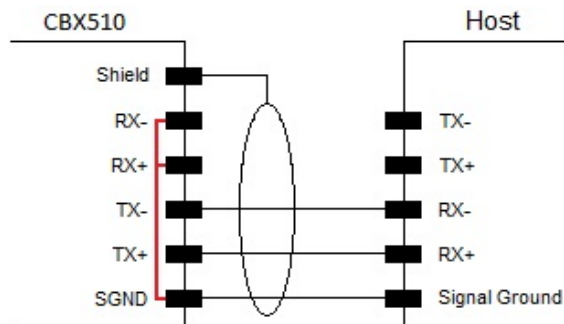

**WARNING** For application that do not use RS422 RX signals, do not leave these lines floating but connect them to SGND as shown below.

For applications that do not use RS422 RX signals, do not leave these lines floating but connect them to SGND as shown below.

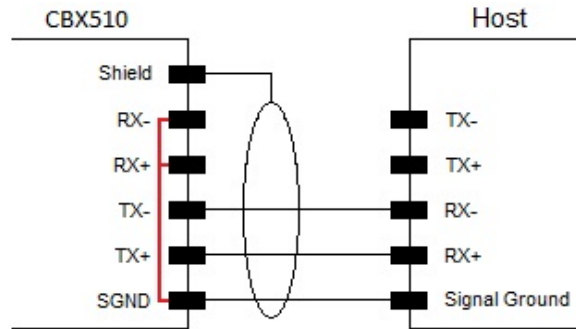

## Photoelectric Sensor Connections to CBX510

Barcode scanning applications may use a Datalogic photoelectric sensor as a trigger device. The photoelectric sensor is wired directly into the CBX510 terminal.

If your application uses a trigger other than the one specified by Datalogic, follow the appropriate wiring diagram to assure proper wiring.



**To confirm the photoelectric sensor is functioning properly, watch the TRIG LED while the photoelectric sensor's beam is blocked. The Datalogic photoelectric sensor also includes a status LED.**

The following diagrams illustrate standard recommended wiring of the Photoelectric Sensor to the CBX510 terminal block.



## Photoelectric Sensor (NPN)

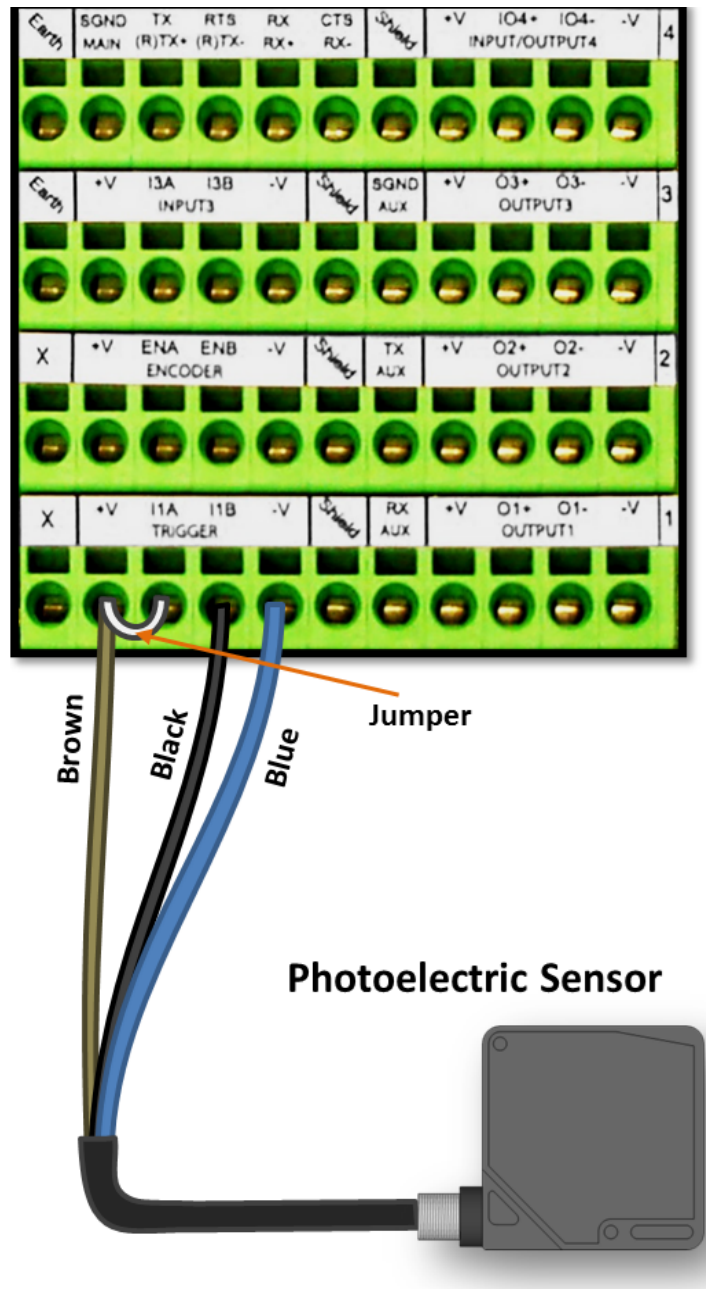



## Photoelectric Sensor (PNP)

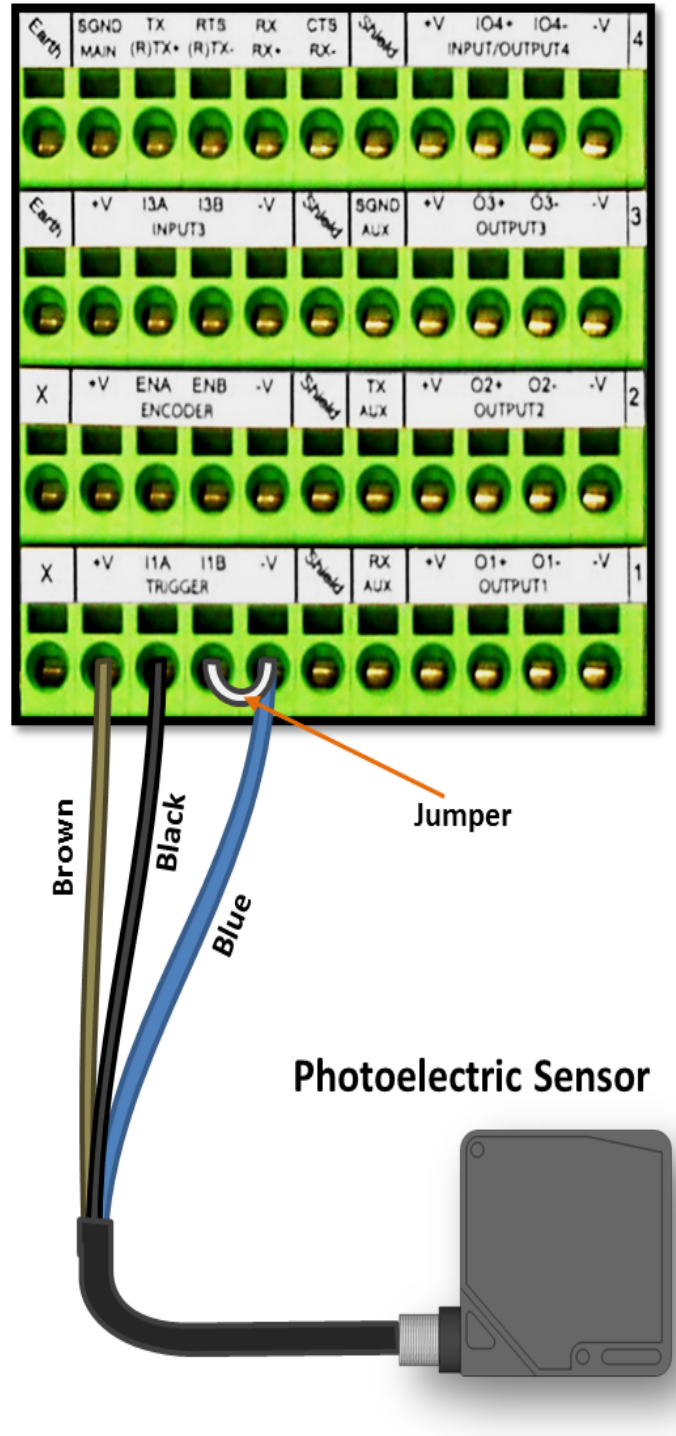

## Tachometer Wiring to CBX510

DX8210 applications over a conveyor belt use an accessory tachometer and mounting kit. The following diagrams illustrate standard recommended wiring of an encoder to the CBX510 terminal block.

## Encoder/Tachometer Wiring for NPN Output (two models)



Some tachometers may have a different color coding:

- (+V) Red or White/Orange
- (Signal) White or White/Blue
- (Ground) Black or Orange/White

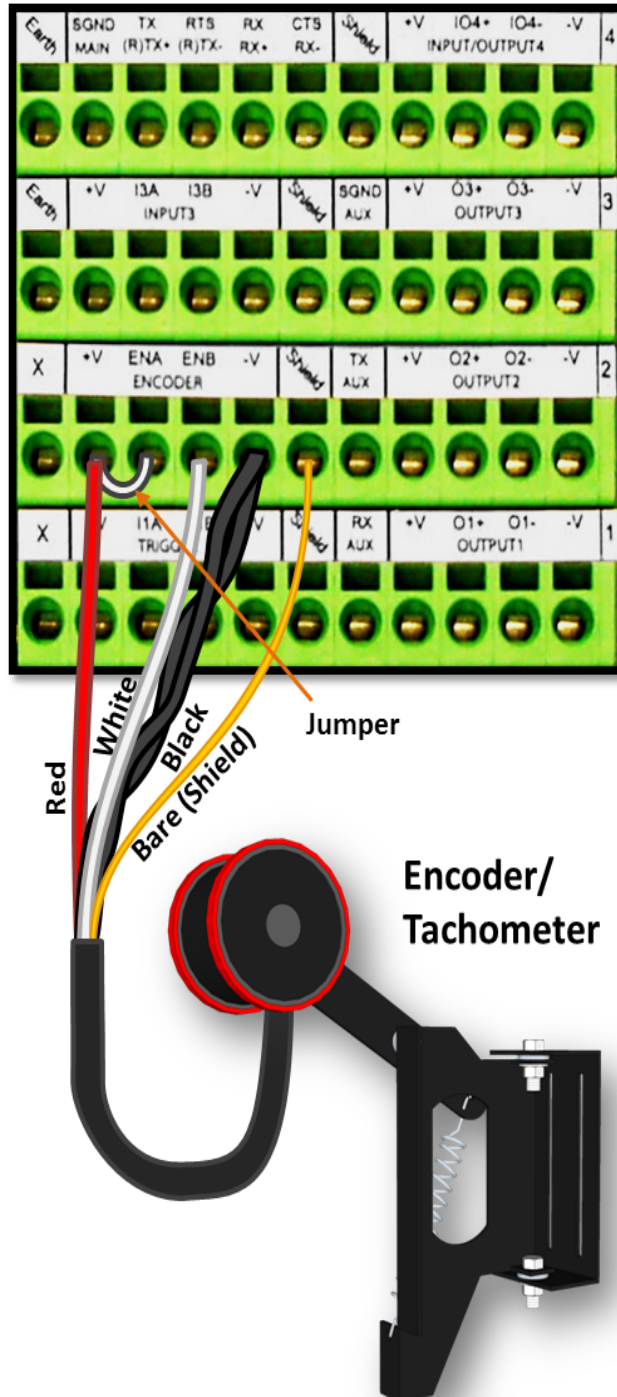

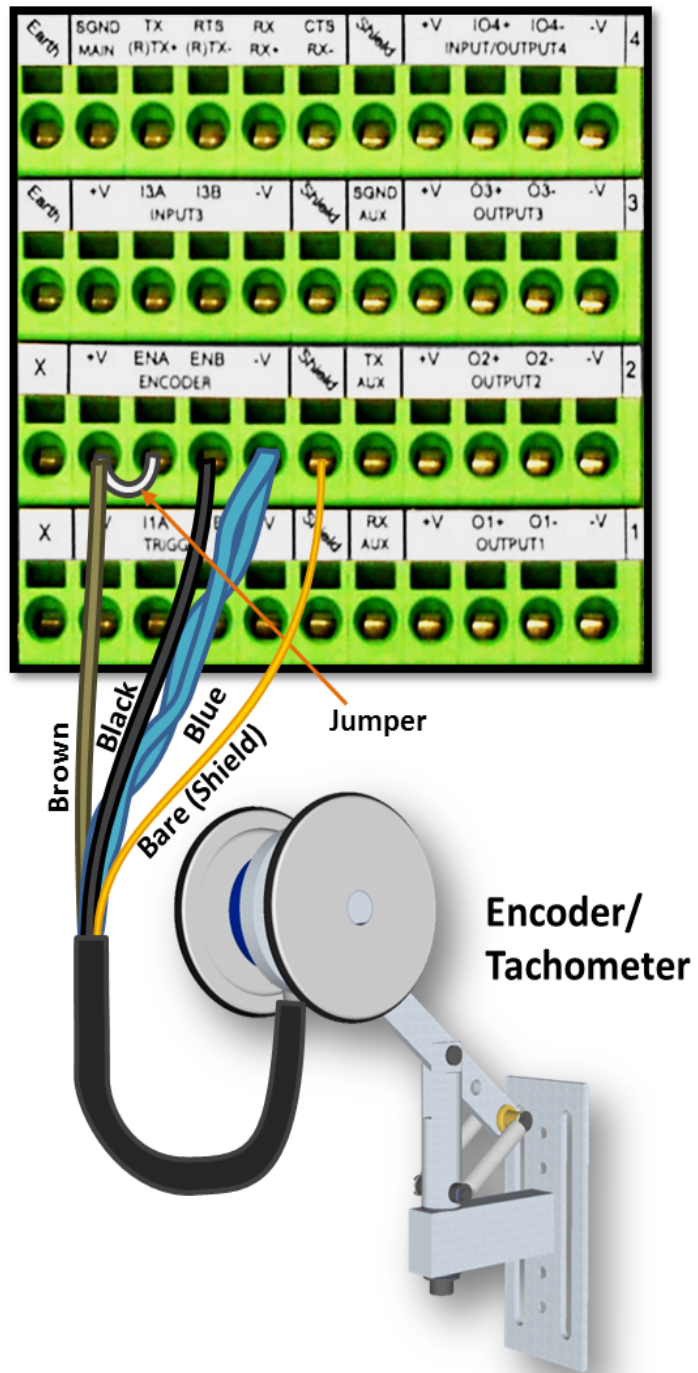

## Encoder/Tachometer Wiring for PNP Output (two models)



Some tachometers may have a different color coding:

Red (+V) or White/Orange

White (signal) or White/Blue

Black (ground) or Orange/White

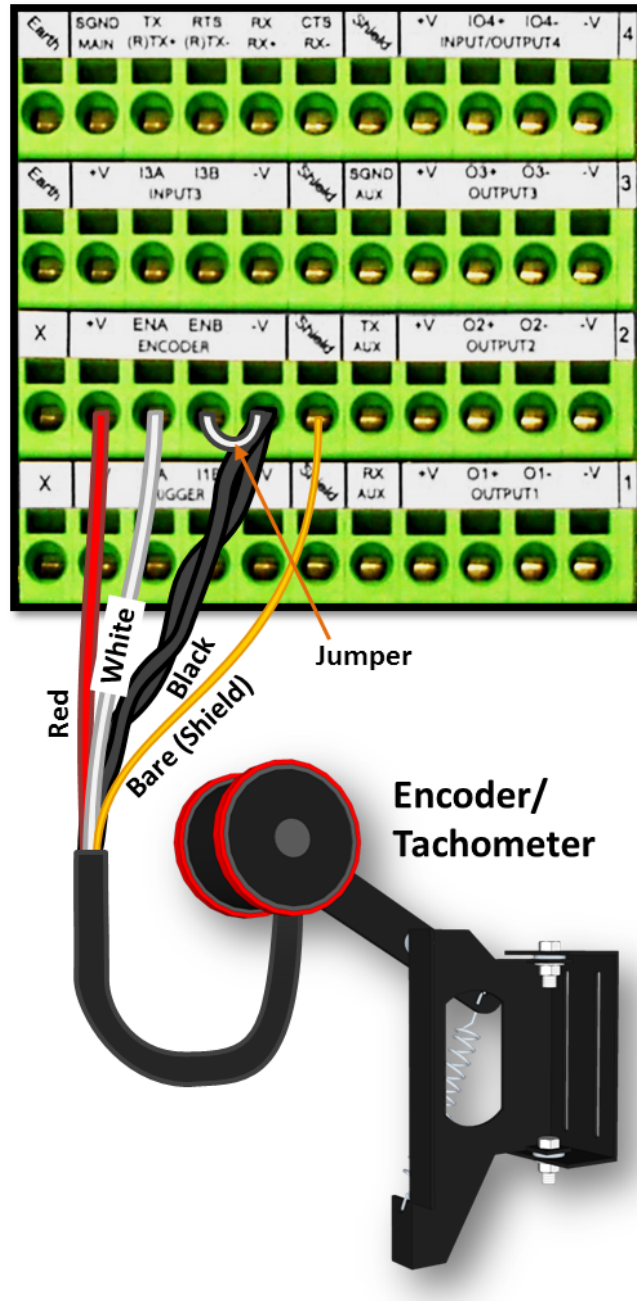

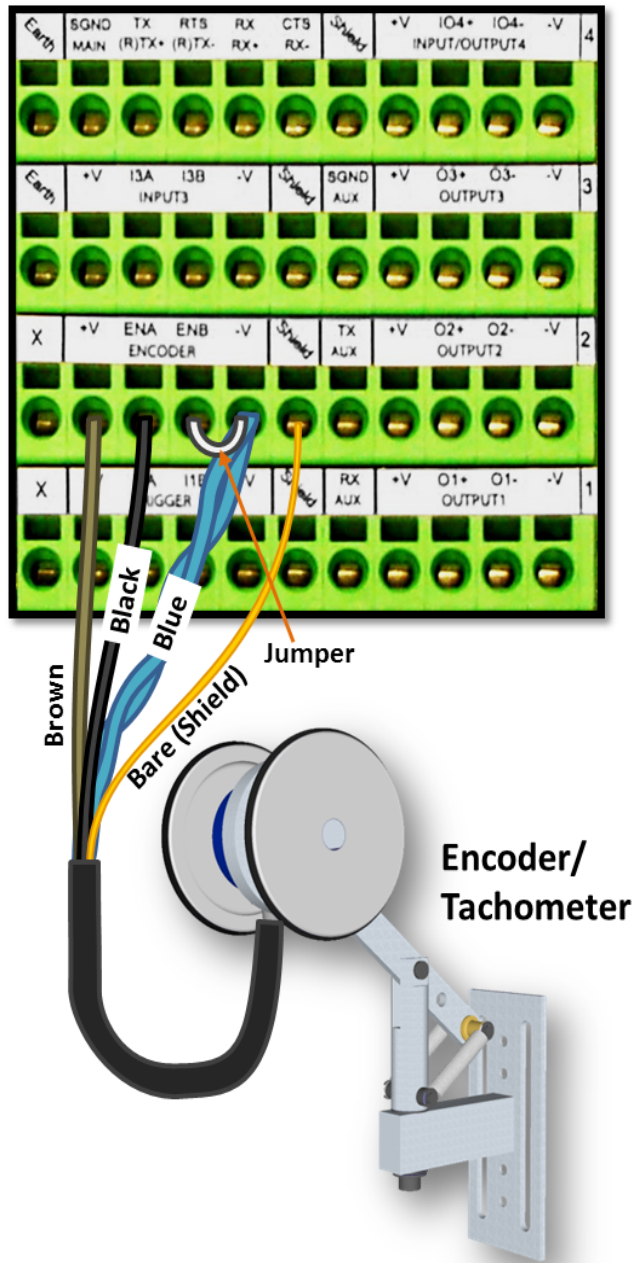

## Digital Output Configuration to CBX510

The CBX510 includes an OUTPUT block for wiring relays as needed for external accessories. The **e-Genius Modify Settings | Digital I/O** window includes options for outputs 1 and 2 with **Primary** and **Secondary Activation Event** options including **Complete Read, Partial Read, No Read, Trigger On, Trigger Off, Multiple Read, Right/Match, and Wrong/No Match**.

Schematics for Isolated and Non-Isolated digital outputs are provided below.

Outputs 1 - 3	
Maximum Voltage 30 V	
Collector Current (pulse) 130 mA Max.	
Collector Current (continuous) 40 mA Max.	
Saturation Voltage (VCE) 1 V at 10 mA Max.	
Maximum Power Dissipation 90 mW at 50 °C (Ambient temperature)	



## Unpowered Outputs

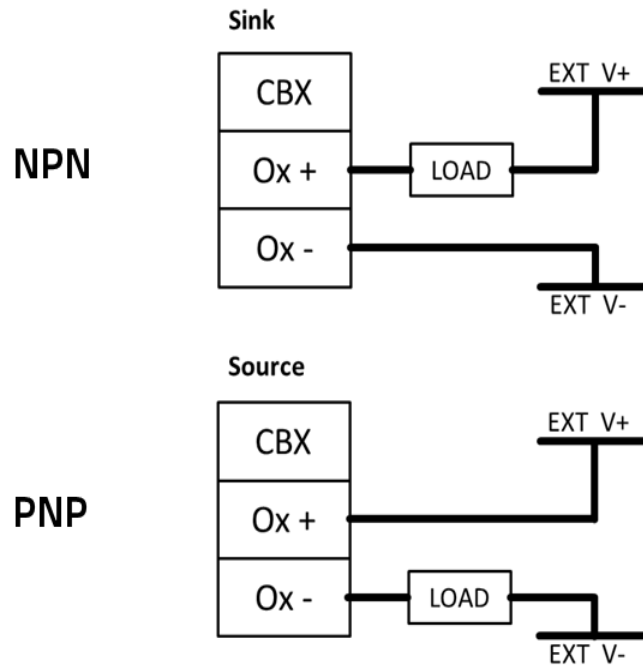

## Powered Outputs

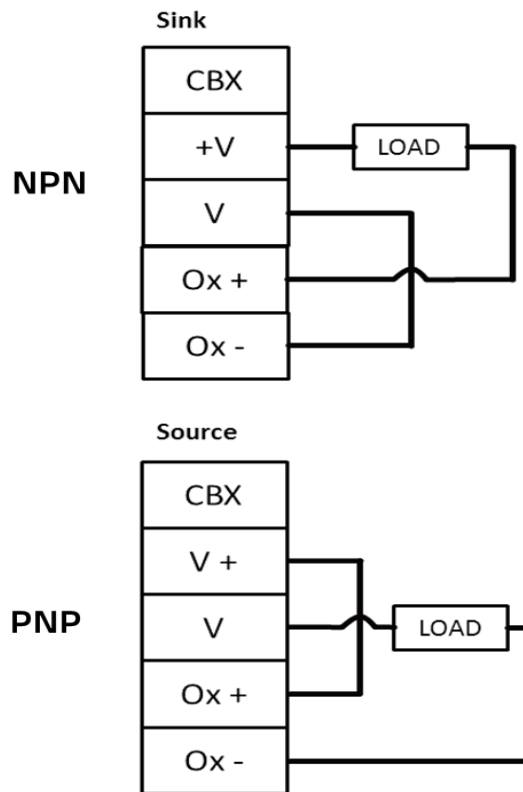



## CBX100 Connection Box

The connections are similar to the CBX510. The only difference is that in the CBX100 ID-NET REF must be jumpered to ID-NET ID+ as shown below.

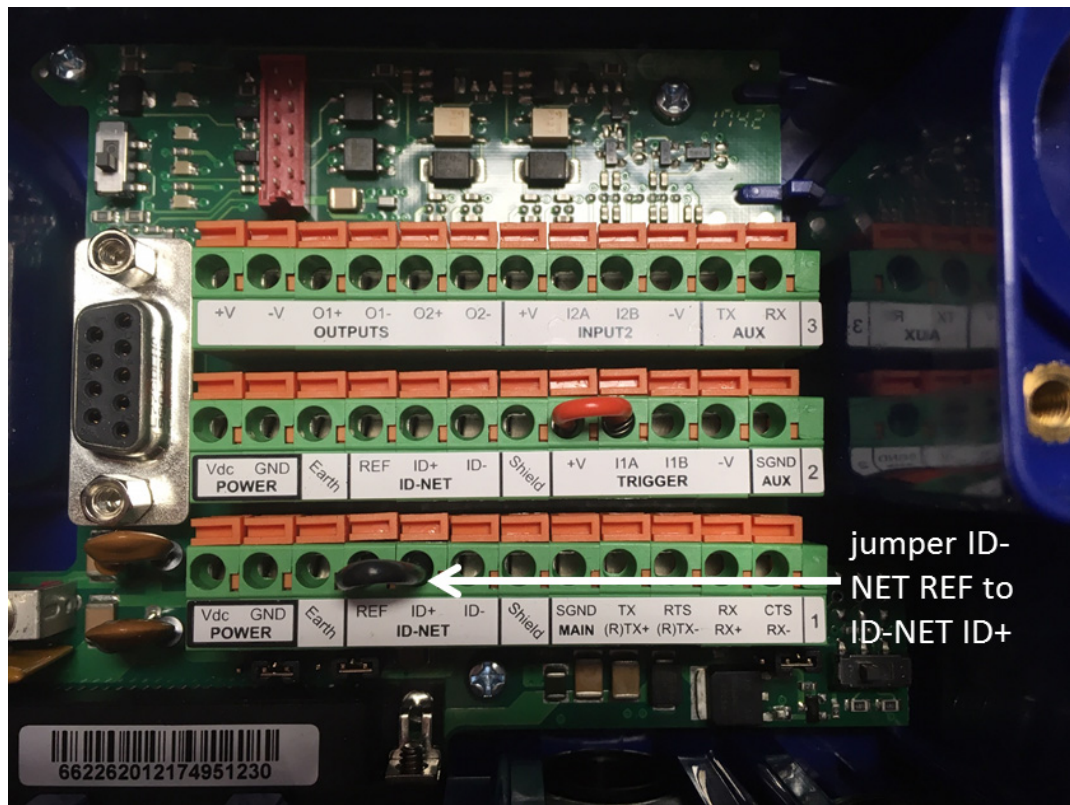

## Connecting to the SC5000 System Controller (Optional)

In larger scanning arrays (scanning tunnels), an SC5000 controller can act as the system master and support up to 31 slave DS8110/DX82110 barcode scanners in an Ethernet-based connection loop (EBC). SC5000 wiring connections are made to the front and bottom connector panels. In most applications, the cable connections to the scanner will include:

1. CFG (Configuration via laptop Ethernet cable)
2. HOST
3. ETH 1 (EBC scanner network)
4. ETH 2 (EBC scanner network)
5. POWER
6. I/O (Connects directly to the 25-pin D type connector on the CBX connection box)
7. ENC (PNP Encoder/Tachometer)
8. TRG (PNP Trigger/Photoelectric Sensor)
9. Water-tight connectors

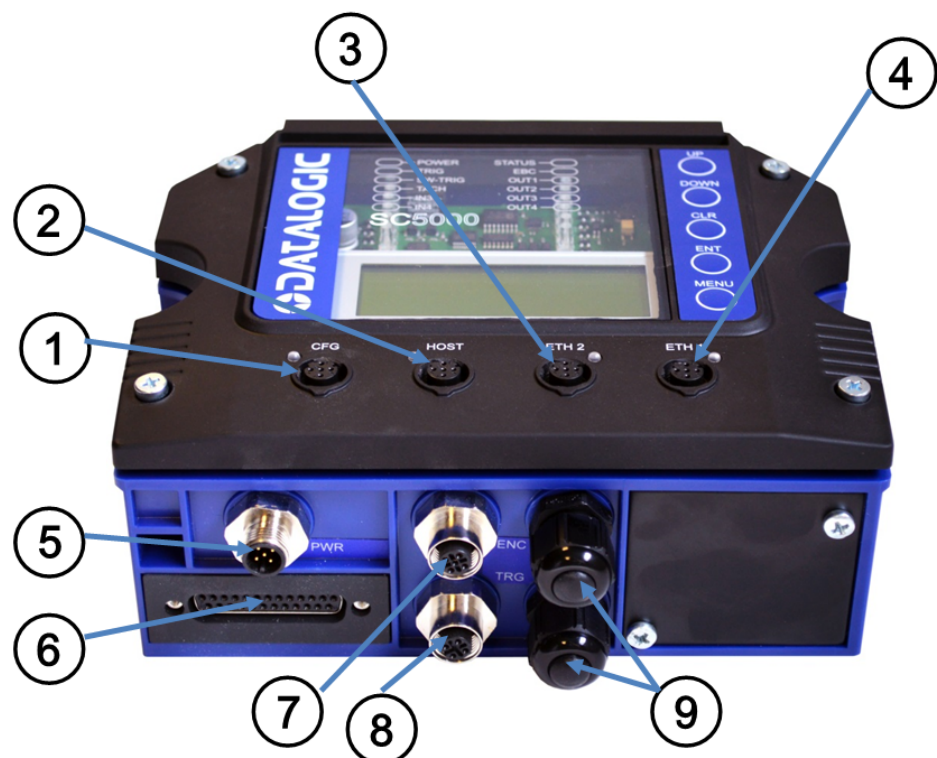

Complete installation information for the SC5000 Controller is available in the *SC5000 System Controller Reference Manual* available at [www.datalogic.com](http://www.datalogic.com).

## Grounding

In order to avoid any problems with electrical noise that could negatively affect system function, make sure that:

1. The AC power cable coming into the PWR box is always provided with a Ground and connected to the proper connector (Protective Earth – PE).
2. The structure where the readers, controllers, encoders/tachometers, and photoelectric sensors are mounted is grounded to the conveyor or to the PE terminal inside the PWR.
3. The Shield wires from the Encoder/Tachometer and photoelectric sensor cables are connected to the proper *Shield* terminal in the CBX box.
4. Normally, steps 1 through 3 will guarantee proper function. In case of problems such as transmission of strange or wrong characters, devices stop working without any reason, or other unexpected behavior, try connecting the CBX or Controller Earth terminal to the PE terminal inside the PWR box.

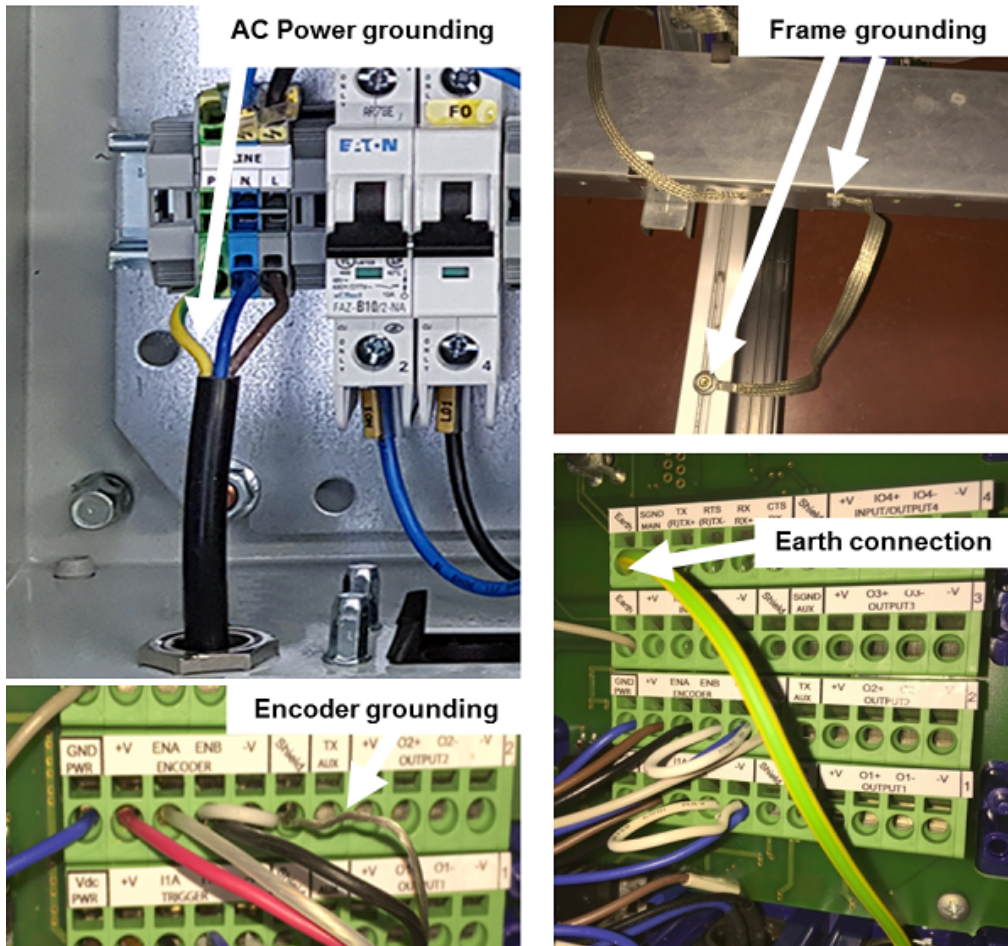

## Check Scanner Installation

After completing the installation of your barcode scanner, confirm that the barcode scanners, CBX connection box and/or SC5000 Controller have been properly installed mechanically and electrically. Use the Installation Sequence at the beginning of this chapter and your application specifications to check your installation.



# Chapter 4

## E-Genius

### Getting Started

The **DS8110/DX8210 barcode scanners** are designed for ease-of-setup. **e-Genius** is a browser-based application you will use to define operating parameters, monitor read quality, construct output messages, and view diagnostics. **e-Genius** enables you to easily configure, fine-tune, and monitor your scanning system operation.

### Prerequisites

Before or setting up your barcode scanner you will need the following:

Computer	Laptop
Browser	Internet Explorer 11 (or later) Firefox 30 (or later) Chrome 36 (or later)

### Starting e-Genius



To access e-Genius:

**Before starting up or testing a scanner, it must be connected to a CBX510 Connection Box or an SC5000 Controller depending on the system configuration.**

1. Connect your computer to the scanner's ETH 2 (setup) port using either the CAB-ETHM0x M12-IP67 ETHERNET CABLE or CBL-1534-0.2 ADAPT.CABLE ETH M12-TORJ45F. If the ETH 2 (setup) port is taken, ETH 1 (host) can be used. Turn on your computer.
2. If you are connecting to a stand-alone unit (not connected to an in-house network), you must configure your PC's IP Address to be in the same network as the unit's IP Address.
3. Open a web browser and enter the IP address for the SC5000 Controller. If the correct IP address is entered, the **e-Genius** Log On window will appear.

The default setup IP address for all **DS8110/DX8210** units is: 192.168.3.100 (setup/ETH2) and 172.27.101.220 (Host/ETH1).

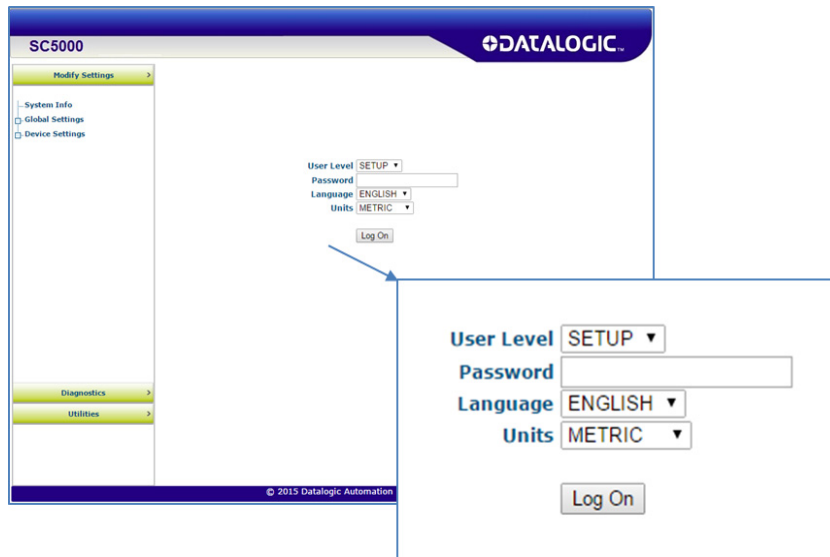

4. Enter the **Password** (default is DLA) for your system in the fields provided.
5. Select a language from those available in the **Language** drop-down list.
6. Select **METRIC** or **IMPERIAL** from the **Units** drop-down list.
7. Click **Log On**.

If the password is valid, the application enables all functions available to the user and displays the main window.

If the password is not valid, the application displays a results box with the message, **“Incorrect Password.”** Click **OK** to return to the **Log On** window and enter the correct user name and password. If you don't know the password, query your system manager.

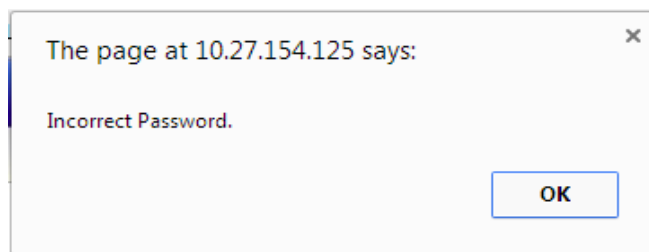



## Monitor Mode

If you do not have a valid password and simply wish to view the settings, diagnostics and utilities of the SC5000, you can use Monitor mode.

### To use Monitor Mode:

1. At the default IP Address, Select **User Level > Monitor Mode**.

**User Level**  ▾  
**Language**  ▾  
**Units**  ▾

2. Click Log On and you will access the e-Genius application in Monitor Mode.

Global Settings | Operating Mode

MONITOR  

**Operating Mode**

Operating Mode Selection  ▾

Bidirectional PackTrack Enable

**Trigger Source**

Start Input Number  ▾

Start Input Active Level  ▾

Transmission Edge  ▾

**Mode Settings**

Distance from PS Line to TX Line  mm

PS Line  mm

Minimum Package Length  mm

Minimum Distance Error Behavior  ▾

Minimum Distance Between Packages  mm

Window Dimension  mm

**Encoder Settings**

Encoder Source  ▾

Encoder Step (hundredths of millimeter)

**Beam Shutter Settings**

Beam Shutter  ▾

### To log out of e-Genius:

Click  at the upper right corner of the **e-Genius** window to Log Out. When logged out, the Log On window will appear.

---

**To change your PC's IP Address:**

1. From the desktop, click the **Start** button, and then select **Control Panel**.
2. Type **adapter** in the search box, and then from the results, under **Network and Sharing Center**, click **View network connections**.
3. Right-click **Local Area Connection**, and then select **Properties**.
4. Select the **Networking** tab. Under **This connection uses the following items**, click **Internet Protocol Version 4 (TCP/IPv4)**, and then click **Properties**.
5. Select **Use the following IP address**.
6. In the **IP address** field, type the first 3 octets of the IP address of the reader/controller unit.
7. For the last octet, type a number that differs from the last octet in the reader/controller's IP address. The actual number used is not important as long as it does not match that of the reader/controller.

**Example:** If the barcode scanner's IP Address is 192.168.3.100, set your PC's IP Address to 192.168.3.101.

8. In the Subnet mask field, type 255.255.255.0
9. Click **Okay**.



## e-Genius Basics

### e-Genius Menu Tree

The functions that you can select are displayed in a menu tree on the left-hand side of the reader/controller **e-Genius**. The function list is organized much like the hierarchy of a file system, where you can expand items that are preceded by a box (☐) to further sub-levels until you find a function of interest.

Sub-levels appear indented below the items from which they are expanded. Clicking the box again will collapse that branch of the menu. You can expand no further when an item is not preceded by a box.

The reader/controller **e-Genius** menu tree appears with no items expanded. Click the folders to display the active window for the setup function and/or expand the folders to view any additional setup features.

### Entering Text Using the Text Entry Tool

In cases where text needs to be entered to create message headers, trailer, custom messages, or for other reasons, the **Text Entry Tool** pencil icon “

Click  to open the **Text Entry Tool**.

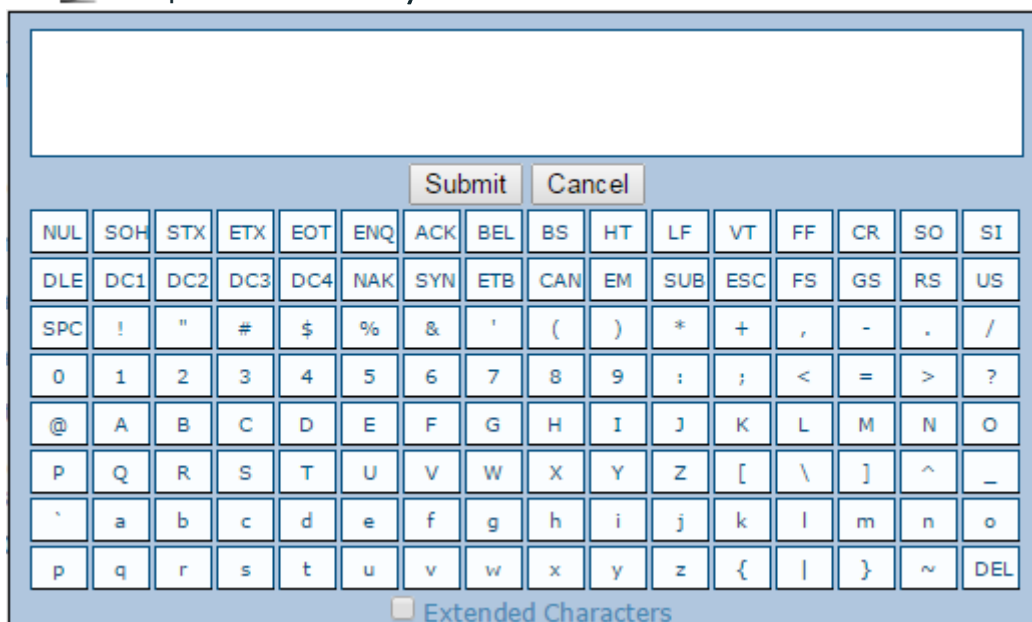

The text Entry Tool is needed to enter unprintable/untypable characters. For example, <CR> is a single character presented as a string for easier reading. The character must be entered with the text entry tool, if typed normally it will be recognized as a string and not as a single character.

You can enter text in the text field by typing, or click on the character buttons to create your message. Select the **Extended Characters** check box to reveal a new set of control characters.

Click **Submit** to save your text to the origin window text field, or click **Cancel** to return to original window without transferring text.

## Update and Reset Buttons

The **Update All**, **Reset All**, and **Reset Page** buttons provide the following functions:

- **Update All:** Click to save all pending parameter changes (across active windows)
- **Reset All:** Click to revert all pending parameter changes (across active windows) to their last saved values
- **Reset Page:** Click to revert pending parameter changes on the current page to their last saved values

## Disabled Check Boxes

In some sections of the SC5000 software a check box may appear with a gray box surrounding it. The gray box indicates that the option is not available for the configuration you have defined.

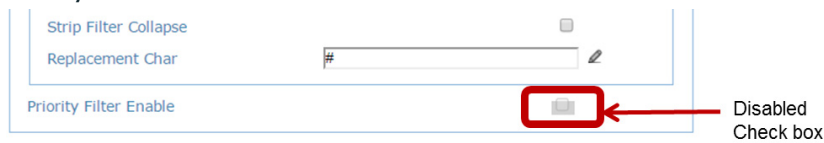

## Getting Help

e-Genius provides complete online help.

To access the complete help system:

Select **Utilities | Help** in the e-Genius menu tree. The help **Welcome** window appears. The **Welcome** page provides important product information as well as three ways to find specific help information: **Contents**, **Index**, and **Search**.

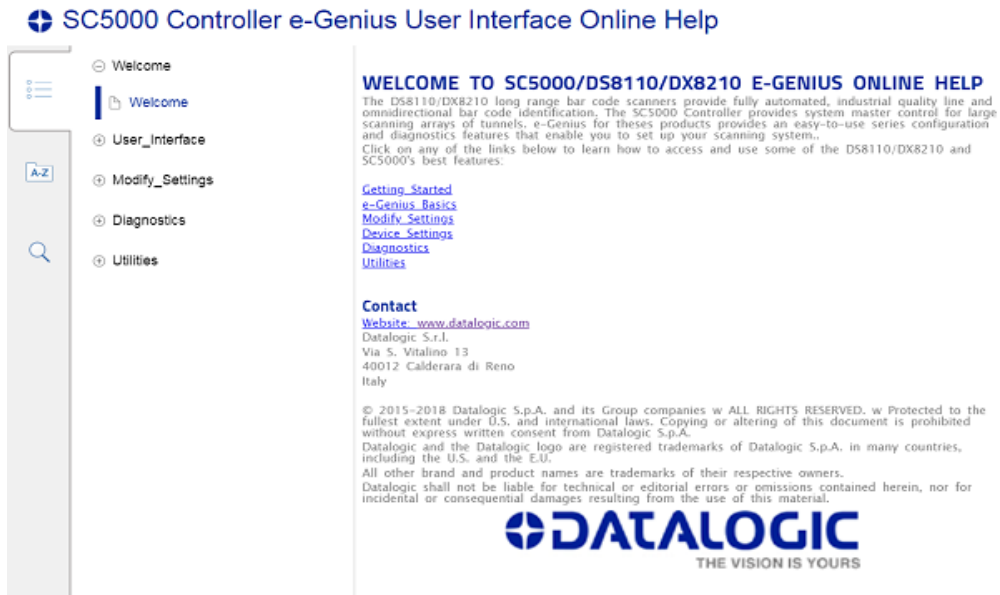

To display contextual help for a current window:

1. Click the Help Icon  displayed at the top right of the screen. A help window appears, providing you with information for that specific page.
2. Click the Table of Contents or Search options on the left side of the help window to access Contents, Index, and Search options.

## System Information

Use **System Info** to identify and name the scanning system (whether it includes one scanner or an array), indicate Master or Standalone systems, discover the scanners included in the system, and distribute software from the Master scanner to Slave scanners.

**To view and edit system information:**

1. In the menu under **Modify Settings**, click System Info. The System Info window opens.

**System Info**

System Description

Role

Enable Automatic Slave Replace

**Master Tools**

**Device Information**

Model	Dev	MAC Addr	Software Version	Description	
	0	0007BEO14C2D	ARM_release_v3_5_0_0	CTRL	
	1	000E1304FF16	ARM_release_v3_5_0_0	Front	<input type="button" value="ID"/>
	2	000E1304FFFF	ARM_release_v3_5_0_0	Top	<input type="button" value="ID"/>

2. Enter the appropriate information in the form as described below:

### **System Info** **System Description**

Enter a name to identify this scanning system in the System Description text field.

### **Role**

Select Standalone or Master from the drop-down list. Standalone (not controllers) indicates a scan point with a single barcode scanner. Master indicates that the system is made up of more than one barcode scanner in a master and slave configuration.



**The SC5000 Controller will always be shown as Master and cannot be changed.**

### **Enable Automatic Slave Replace**

There are two ways to replace a defective scanner:

If the check box is not selected: The replacement will be done only by pressing the RESTORE key on the scanner or using the Edit drop-down.

If the check box is selected: The replacement will be completely automatic. This will work also as Hot-Automatic-Replacement without turning the system power off and on.

### **Force Operation as a Standalone/Master**

Select the check box to allow a scanner to operate as a Master without a CBX attached.

### Master Tools

These options are shown if Master is selected and is the default option for the SC5000.

### Discover Scanners

Click **Discover Scanners** to automatically find all of the scanners in an array. The discovered scanners will be listed in the Device Information portion of the window. This step is only done during initial configuration and is not a troubleshooting option.

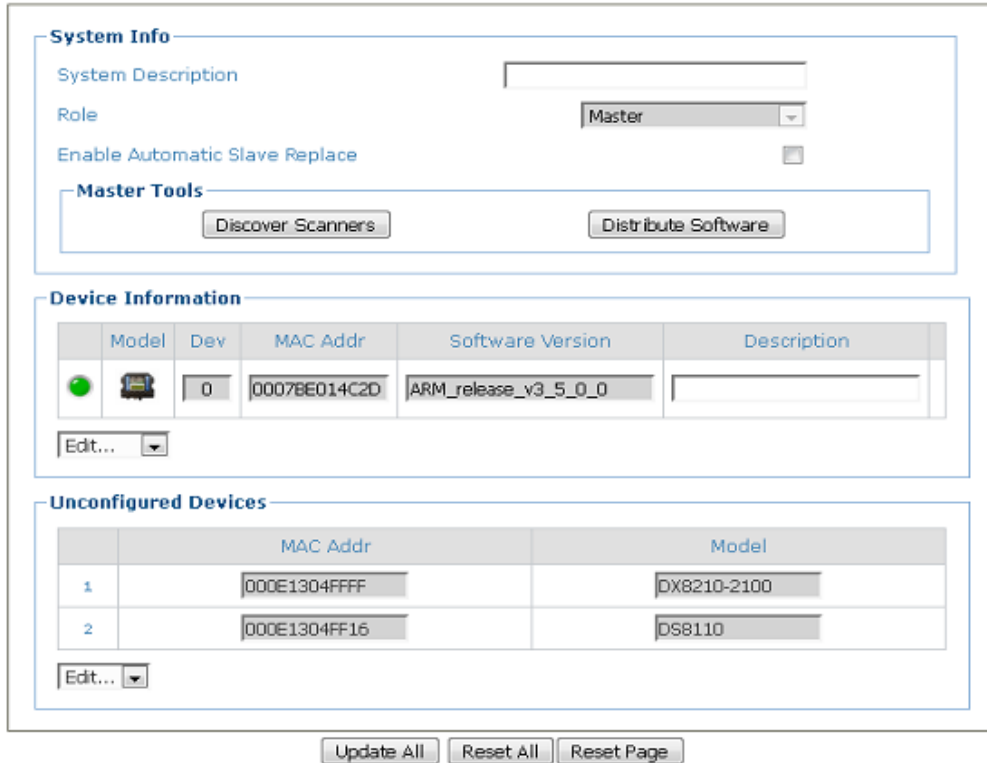

### Distribute Software

Click **Distribute Software** to send the current software residing on the master scanner to all of the slave scanners listed in the Device Information section of the window.

### Device Information Status

**Green** = No errors and ready to read

**Gray** = Unit not connected (unit not seen by master)

**Red** = Error. If you click on the red circle it will take you to the status viewer page for more info on the error

### Model

Displays an image of the scanner/controller model.

### Dev

Displays the system designation for the device.

### MAC Address

Displays the MAC Address (Media Access Control Address) for the device.

### Software version

Displays the device installed software version.

### Description

Enter a user-defined description of the device.

### ID

Click ID to visually identify a scanner in an array/tunnel. When clicked, all the scanner lasers will turn off except for the selected scanner, whose laser will blink for 20 seconds.

## Edit

Select to Remove, Reassign, Add, or Replace from the Edit drop-down list to complete the following actions:

**Remove:** When selected, you can select the scanner to remove from the Dev/MAC Address drop-down list. Click OK to remove the selected scanner from the system.

**Reassign:** When selected, the Dev column of the selected slave scanner (selected with ID) presents a drop-down list of Dev numbers. Select a different number to reassign the scanner.



### **These options are for units not in the cluster, that have been discovered.**

**Add:** This is an option under the Edit drop-down list in the Unconfigured Devices section of the screen. Click **OK** to add the selected device to the system.

**Replace:** This is an option under the Edit drop-down list in the Unconfigured Devices section of the screen. When selected, you can select from a list of slave scanners (Those with a gray indicator, meaning the unit is not connected) in the system using MAC Address and Dev drop-down lists. Click **OK** to replace the selected scanner with the Unconfigured Device.

3. When you have finished making changes, click **Update All** to save all pending changes, click **Reset All** to revert to all previously saved values, and click **Reset Page** to revert to the previous saved values on the current page.

## Modify Settings

Use the Modify Settings Menu selections during initial setup to configure your scanning system. If necessary, you can later make modifications to the configuration using the same menu selections.

[“System Information” on page 49](#)

### Global Settings

- [“Operating Mode” on page 54](#)
- [“Barcode Settings Table” on page 68](#)
- [“Barcode Configuration” on page 75](#)
- [“Serial Ports” on page 102](#)
  - [“Serial Ports | Main Port” on page 97](#)
  - [“Aux Serial Port” on page 106](#)
- [“Ethernet” on page 108](#)
  - [“Ethernet | Line Settings” on page 109](#)
  - [“Ethernet | User Sockets” on page 111](#)
  - [“Ethernet | Ethernet\\_IP” on page 115](#)
  - [“Ethernet | WebSentinel” on page 119](#)
- [“Fieldbus” on page 121](#)
- [“Messaging” on page 126](#)
  - [“Messaging | Message Format” on page 127](#)
  - [“Messaging | Message Builder” on page 139](#)
  - [“Messaging | Statistics” on page 145](#)
  - [“Messaging | Protocol Index” on page 147](#)
  - [“Messaging | Pass-Thru” on page 151](#)
  - [“Messaging | Diagnostics Messages” on page 153](#)
- [“Digital I/O” on page 156](#)
- [“Diagnostics” on page 159](#)
- [“Energy Saving” on page 163](#)
- [“HMI Settings” on page 167](#)





## Operating Mode

Use Operating Mode to select an operating mode and configure that mode's related parameters. The three operating modes available are **On Line**, **Continuous**, and **PackTrack**, and the available settings differ depending on the operating mode selected.

**Online:** In the Online operating mode, the reading phase is defined as the time between a Phase ON and Phase OFF event. The Phase events can be signals coming from one or two external presence sensors connected to the scanner inputs or serial start/stop strings sent from the host over the serial interface or Ethernet input.

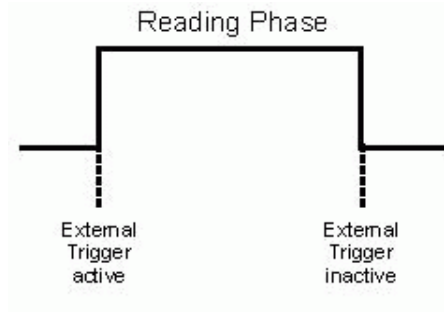

**Continuous:** In the Continuous operating mode the reading phase is always active and allows the reading of two or more codes when placed along the same scan line. Code transmission is identical to the other operating modes except that there is no transmission on the serial port in case of a No Read condition.

**PackTrack:** Datalogic's patented parcel tracking system which improves the reading features in omnidirectional stations. In particular, PackTrack manages 6-sided reading systems when it is impossible to detect the real position of the code on the parcel. The technology allows for smaller gaps between packages and overcomes the need for additional accessories. It can also be used in bidirectional systems, in which you may want to read codes going forward or reverse.

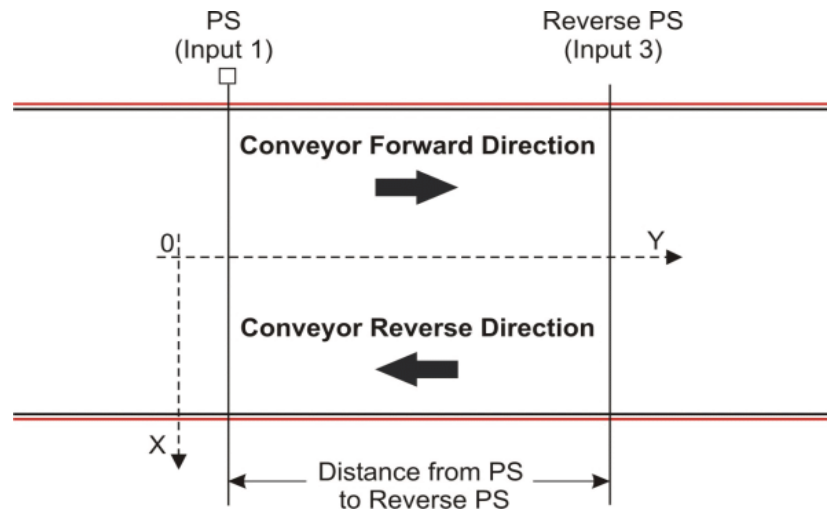

To edit the system Operating Mode:

1. In the menu under **Modify Settings**, navigate to **Global Settings | Operating Mode**. The **Operating Mode** window opens.

**Operating Mode**

Operating Mode Selection: On Line

On Line Options: 1 Input Used

**Trigger Source**

Start Input Number: Trigger (Input 1)

Start Input Active Level: Active Closed

Reading Phase Timeout:

Trigger Debounce: 5 msec

**Verifier Settings**

Verifier Enable:

**Beam Shutter Settings**

Beam Shutter: Disabled

Update All | Reset All | Reset Page

2. Enter the appropriate information in the form as described below:

### Operating Mode

Select **On Line**, **Continuous**, or **PackTrack** from the Operating Mode Selection drop-down list.

### ONLINE MODE

**Operating Mode**

Operating Mode Selection: On Line

On Line Options: 2 Inputs Used

**Trigger Source**

Extended Phase: Disable

Start Input Number: Aux (Input 3)

Start Input Active Level: Active Closed

Stop Input Number: Aux (Input 3)

Stop Input Active Level: Active Open

Stop Phase Edge: Leading

Trigger Debounce: 5 msec

**Beam Shutter Settings**

Beam Shutter: Enabled

Update All | Reset All | Reset Page

### On Line Options

Select **1 Input Used**, **2 Inputs Used**, or **Serial/Network** from the On Line Options drop-down list. Each selection has a different set of parameters as described below.

#### 1 Input Used

The reading phase takes place during the active phase of the presence sensor, when the scanner tries to acquire and correctly decode the code. If the operation is successful, the barcode characters are transmitted on the serial interface or Ethernet input in the format defined by the current configuration and the right output event is raised at the end of the photoelectric sensor's active phase. If a

code cannot be decoded, a no read message is sent and the no read event is raised at the end of the photoelectric sensor’s active phase.

**2 Inputs Used**

The reading phase is defined by 2 inputs. It starts when the Start Input is activated and stops when the Stop Input is deactivated (unless the **Extended Phase** is enabled).

**Serial/ Network**

In Serial/On-Line mode the reading phase starts when the **Serial Start String** is received on the serial interface and ends when the **Serial Stop String** is received or when a programmed **Reading Phase Timeout** expires.

If decoding is correct, the data is transmitted on the serial port as defined by the configuration. The output line selected for the right output event is activated and the relative message is transmitted on the serial interface or Ethernet input.

In case of a bad read, a no read message is transmitted on the serial interface. The output line selected for the no read event is activated and the relative message is transmitted on the serial interface or Ethernet input.

**Trigger Source: 1 Input Used**

**Trigger Source**

Start Input from Bus

Start Input Number Trigger (Input 1) ▼

Start Input Active Level Active Closed ▼

Reading Phase Timeout

Timeout (ms) 500 msec

Timeout Counting From Start ▼

Stop Priority Input/SerialStop ▼

Trigger Debounce 5 msec



The Start Input from Bus parameter is only available for Fieldbus Hosts.

**Start Input from Bus**

if checked, allows the Fieldbus Master to drive the Reading Phase. For Profinet or Profibus interfaces, it allows the Fieldbus Master to drive the reading phase via bit 7 in Byte 0 (LSB) of the Output Area. For EtherNet/IP, it allows the EtherNet/IP Client to drive the reading phase via bit 7 in Byte OutputBits of the DL\_OutputStruct.

**Start Input Number**

Select the Input Number from the selections available in the drop-down list. Options are; Trigger (Input 1), Aux (Input 3), or I/O 4 (Input 4)

This option defines the numbered input that will start the trigger cycle.

**Start Input Active Level**

Select Active Open or Active Closed from the drop-down list.

**Active Open:** The input is active when there is no current flowing through IN pins. The input from the trigger source is normally closed. The scanner goes into trigger mode when the input source is opened.

**Active Closed:** The input is active when current flows through IN pins. The input from the trigger source is normally opened. The scanner goes into trigger mode when the input source is closed.

**Reading Phase Timeout**

Select the check box to define a timeout for the On Line Serial mode and the On Line 1 Input mode.

**Timeout (ms)**

Enter a timeout in milliseconds (from 40 to 15000 ms) in the field provided. The Timeout represents the period of time for the reading phase.

### Timeout Counting From

Select Start or Stop from the drop-down list.

When Start is selected, the Timeout used to determine the reading phase will begin from the Start Input or Serial Start String (normal operation)

When Stop is selected, the Timeout used to determine the reading phase will begin from the Stop Input or Serial Stop String (effectively extending the reading phase).

### Stop Priority

Available only if Timeout Counting From is Start. Select Input/SerialStop or Always Timeout.

### Trigger Debounce

Enter a value in milliseconds that specifies the debounce time of the trigger input signal.

This amount of time is the minimum amount of time in milliseconds the photo detector should be blocked for the SC5000 to consider an object to scan, reducing false triggers. A typical value is 5 msec. This value must be significantly less than the amount of time from the trigger to read line.

### Verifier Settings

### Verifier Enable

Select the check box to enable the Code Verifier operating mode.

### Verifier Code

Click  to activate the Text Entry Tool and create the string text used as the match code to the decoded codes. Use characters from NUL (00H) to ~ (7EH). Click Submit to save your text to the origin window text field, or click Cancel to return to origin window without transferring text.

### Store Input

Select an option from the drop-down list to define the number of the input used to automatically store the verifier code. This input must be activated before the reading phase starts, the verifier code must be read and then after the end of the reading phase the input must be deactivated.

### Active Level

Select Active Open or Active Closed from the drop-down list to choose the active state of the input.

**Active Open:** The input is active when there is no current flowing through IN pins. The input from the verify mode source is normally closed. The scanner goes into trigger mode when the input source is opened.

**Active Closed:** The input is active when current flows through IN pins. The input from the verify mode source is normally opened. The scanner goes into trigger mode when the input source is closed.

### Wrong Code Tx

Select the check box to enable the transmission of the Wrong Code (Non-Valid Code).

**Wrong String Tx**

Select the check box to enable the transmission of the Wrong String (Non-Valid String) message. This message will be sent if code data does not match verified code entered.

**Wrong String**

Click  to activate the Text Entry Tool and enter the string text to be used when the wrong code is detected.

**Trigger Source: 2 Inputs Used**

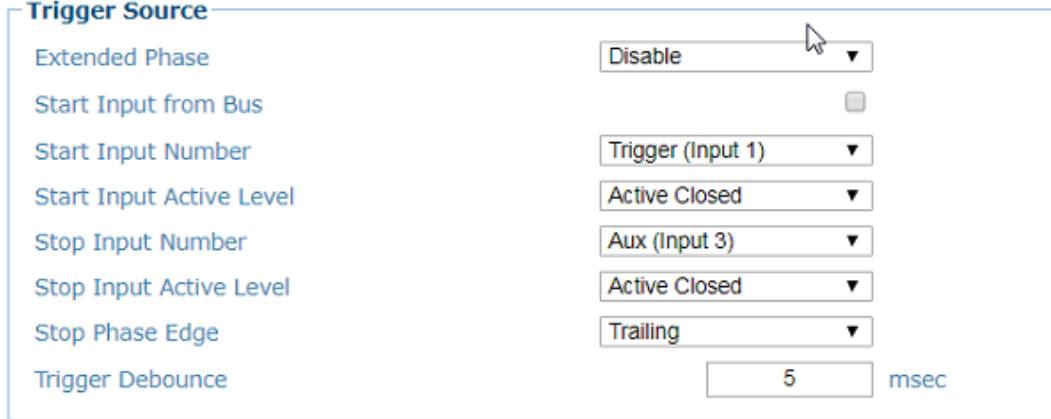

Extended Phase	Disable
Start Input from Bus	<input type="checkbox"/>
Start Input Number	Trigger (Input 1)
Start Input Active Level	Active Closed
Stop Input Number	Aux (Input 3)
Stop Input Active Level	Active Closed
Stop Phase Edge	Trailing
Trigger Debounce	5 msec

The reading phase is defined by 2 inputs. It starts when the **Start Input** is activated and stops when the **Stop Input** is deactivated (unless the Extended Phase is enabled).

**Extended Phase**

**Available only for the On Line/2 Inputs option.** It allows the Stop Input to end the reading phase only if the Start Input is also deactivated. Select Disable or Enable from the drop-down.

**Start Input from Bus**

if checked, allows the Fieldbus Master to drive the Reading Phase. For Profinet or Profibus interfaces, it allows the Fieldbus Master to drive the reading phase via bit 7 in Byte 0 (LSB) of the Output Area. For EtherNet/IP, it allows the EtherNet/IP Client to drive the reading phase via bit 7 in Byte OutputBits of the DL\_OutputStruct.

**Start Input Number**

Select the Input Number from the selections available in the drop-down list. Options are; Trigger (Input 1), Aux (Input 3), or I/O 4 (Input 4)

This option defines the numbered input that will start the trigger cycle.

**Start Input Active Level**

Select Active Open or Active Closed from the drop-down list.

**Active Open:** The input is active when there is no current flowing through IN pins. The input from the trigger source is normally closed. The scanner goes into trigger mode when the input source is opened.

**Active Closed:** The input is active when current flows through IN pins. The input from the trigger source is normally opened. The scanner goes into trigger mode when the input source is closed.

**Stop Input Number**

Select the Input Number from the selections available in the drop-down list. Options are; Trigger (Input 1), Aux (Input 3), or I/O 4 (Input 4)

This option defines the numbered input that will stop the trigger cycle.

**Stop Input Active Level**

Select Active Open or Active Closed from the drop-down list to define the active state of the input.

**Active Open:** The input is active when there is no current flowing through IN pins. The input from the trigger source is normally closed. The scanner goes into trigger mode when the input source is opened.

**Active Closed:** The input is active when current flows through IN pins. The input from the trigger source is normally opened. The scanner goes into trigger mode when the input source is closed.

### Stop Phase Edge

Select Trailing or Leading from the drop-down list to define the signal edge of the stop input used by the scanner as reference for ending the reading phase:

**Trailing:** The reading phase ends when the pack has completely passed by the stop input.



**Leading:** The reading phase ends as soon as the stop input detects the front edge of the package.

### Trigger Debounce

Enter a value in milliseconds that specifies the debounce time of the trigger input signal.

This amount of time is the minimum amount of time in milliseconds the photo detector should be blocked to be considered an object to scan, reducing false triggers. A typical value is 5 msec. This value must be significantly less than the amount of time from the trigger to read line.

### Trigger Source: Serial/Network

Trigger Source	
Serial Start String	<STX> 
Serial Stop String	<ETX> 
Reading Phase Timeout	<input checked="" type="checkbox"/>
Timeout (ms)	<input type="text" value="500"/> msec
Timeout Counting From	Start ▼
Stop Priority	Input/SerialStop ▼

In Serial/On-Line mode the reading phase starts when the Serial Start String is received on the serial interface and ends when the Serial Stop String is received or when a programmed Reading Phase Timeout expires.

If decoding is correct, the data is transmitted on the serial port as defined by the configuration. The output line selected for the right output event is activated and the relative message is transmitted on the serial interface or Ethernet input.

In case of a bad read, a no read message is transmitted on the serial interface. The output line selected for the no read event is activated and the relative message is transmitted on the serial interface or Ethernet input.

### Serial Start/Stop String (max.32 chars)

Available only for Online/Serial/Network options. Click  to activate the Text Entry Tool and create the string text used to signal the beginning of the reading phase. Use characters from NUL (00H) to ~ (7EH). Click Submit to save your text to the origin window text field, or click Cancel to return to origin window without transferring text. This is only available if Online option has been selected.

The Serial Start string must be different from the Serial Stop string and Motor ON/OFF strings. When [ACK/NAK Protocol](#) or Energy Saving is enabled, the Serial Start/Stop Strings cannot contain ACK/NAK characters.

### Reading Phase Timeout

Select the check box to define a timeout for the On Line Serial mode and the On Line 1 Input mode.

### Timeout (ms)

Enter a timeout in milliseconds (from 40 to 15000 ms) in the field provided. The Timeout represents the period of time for the reading phase.

### Timeout Counting From

Select Start or Stop from the drop-down list.

When Start is selected, the Timeout used to determine the reading phase will begin from the Start Input or Serial Start String (normal operation)

When Stop is selected, the Timeout used to determine the reading phase will begin from the Stop Input or Serial Stop String (effectively extending the reading phase).

### Stop Priority

This is available when Start is selected from the Timeout Counting From drop-down list. Select Input/Serial Stop or Always Timeout from the drop-down list.

- **Input/Serial Stop:** The Stop Input Number or Serial Stop String defines the end of the reading phase. Timeout has a lower priority.
- **Always Timeout:** The reading phase always stops when the selected timeout expires.

### Beam Shutter Settings

#### Beam Shutter

Select Disabled, Triggered, or Enabled from the drop-down list. The Beam Shutter turns the laser off. The Beam Shutter option can be used to increase the overall laser diode life when used in high ambient temperature applications (over 35° C); reduce power consumption; and to turn off the laser for safety purposes.

- **Disabled:** The laser is always on.
- **Triggered:** The laser is turned off as soon as the code(s) are read or when the reading phase ends. The laser is turned on again when the next reading phase starts.
- **Enabled:** The laser is always off and all operations are suspended.

### CONTINUOUS MODE

The reading phase is always active and allows reading two or more codes when placed along the same scan line. Code transmission is identical to the other operating modes except that there is no transmission on the serial port in case of a No Read condition. Allows the reading of one or more codes.

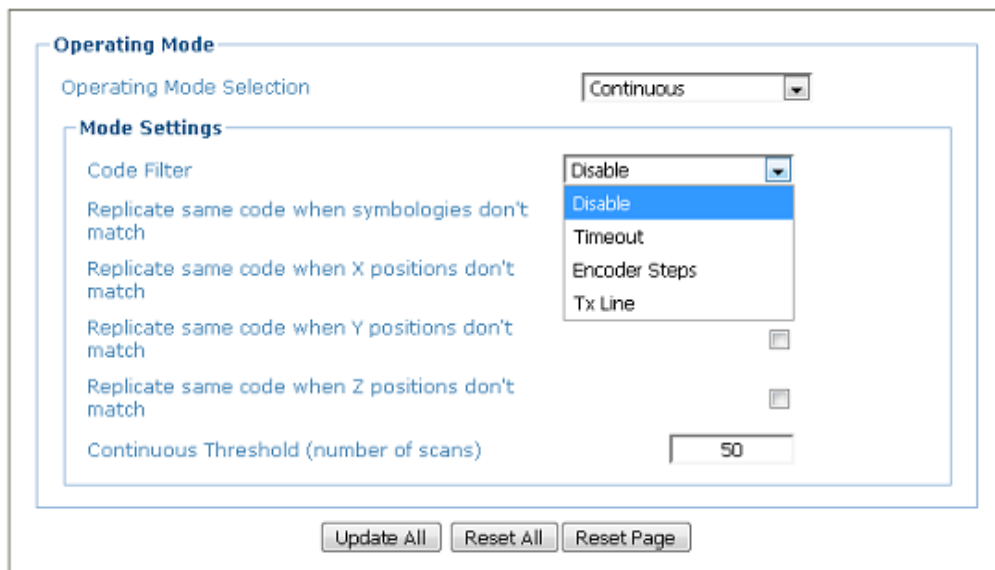

### Mode Settings

#### Code Filter

Select Enable, Disable, Timeout, Encoder Steps, or Tx Line from the On Line Options drop-down list. This parameter determines criteria for flushing entries from the code filtering list depending on the type of list management:

The **Code Filter Depth** parameter, when not = 0, manages a FIFO (First In First Out) list of codes which are compared for filtering. The Timeout and Encoder Steps values are in addition to the cyclical flushing of entries when the FIFO list depth is exceeded.

When **Code Filter is set to Tx Line** an internal list is managed where each entry is flushed when the Tx Line distance is exceeded.

The application program inherently compares codes based on content and code length.

Each Code Filter criteria has its own relative value parameter.



**Disable:** No additional criteria are applied. If code filtering is enabled through the Code Filter Depth parameter, the FIFO list is only modified by new code entries (FIFO list depth exceeded).

**Enable:** Enables code filtering options.

**Timeout:** A timeout measured in milliseconds is also applied to each code read. The current code read will be flushed from the list when the timeout expires.

**Encoder Steps:** a threshold measured in encoder steps is also applied to each code entry. The current code entry will be flushed from the list when the number of encoder steps is exceeded. See [Filter Number of Encoder Steps](#).

**Tx Line:** The distance measured in mm to the transmit line is applied to each code entry. The current code entry will be flushed from the list when the distance in mm is exceeded. When Tx Line is selected, all the networked scanners must have been calibrated using PackTrack (See PackTrack in the DS8110 and DX8210 Reference Manuals).



**When Code Filter = Tx Line:**

The Code Filter Depth parameter is no longer available because the application program manages an internal list which depends solely on the number of codes decoded before the Tx Line is reached.

Any code which is determined to be identical to a code in the list by comparing the filter conditions will be discarded, and to increase precision the code in the list will have its x, y, z position coordinates adjusted as the average between the two readings.

$$x=x1+x2/2, y=y1+y2/2, z=z1+z2/2$$



Code Filter options vary based on what is selected; Enable, Timeout, Encoder Steps or Tx Line.

**Code Filter Depth**

In **Continuous mode**, Code Filter Depth is used to avoid multiple reads of the same code. The entered value (other than zero) defines the number of codes to memorize in a FIFO (First In First Out) list.

When a code is read, it is compared to the list. The application program inherently compares codes based on content and code length. If the list contains a code identical to the current code being read, the current code is discarded. If not, the current code is accepted and added to the list in the first position; the remaining codes in the list are shifted. If the list is full the oldest code in the list will be flushed.

When = 0, there is no FIFO list and there is no filtering.

Selection: a value from 0 to 127

**Example:**

Code Filter Depth = 3

List	Code Read	Accepted
xxx (no codes in list)	A	Yes
Axx	B	Yes
BAx	B	No
BAx	C	Yes
CBA	D	Yes
DCB	A	Yes
ADC	A	No

**Filter Timeout Value**

Enter a timeout value in milliseconds. A code entry is flushed from the list when the timeout expires.

**Filter Number of Encoder Steps**

Enter a number of encoder steps from 1 to 15000. This parameter sets the number of Encoder Steps after which the FIFO (First In First Out) list entry is flushed.

### Distance from PS Line to Tx Line

Enter the distance along the Y axis from the PS (photoelectric sensor) to the TX Line (transmit).

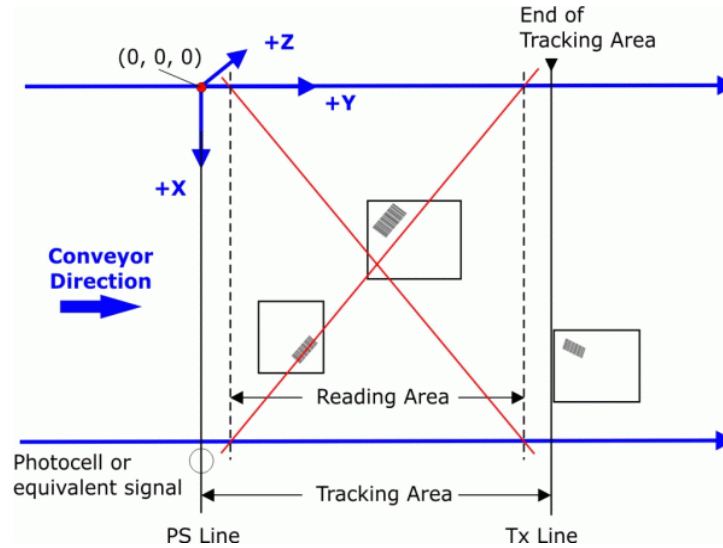

**Tracking starts 10 cm [4 inches] before and stops 10 cm [4 inches] after the Reading Area in order to ensure the barcode is assigned to the correct package.**

### Replicate same code when symbologies don't match

Select the check box to enable a further code filter condition according to which a read code is added to the list or discarded. This parameter is available if the Code Filter Depth value is other than zero or if the Code Filter value is Tx Line.

In addition to the inherent content and code length comparison, this parameter compares the code type (symbology). If the current code being read is identical to any code contained in the list by: content, length and type, the current code is discarded. If not, the current code is accepted and added to the list in the first position; the remaining codes in the list are shifted. If the list is full the oldest code in the list will be flushed.

### Replicate same code when X positions don't match

Select the check box to enable a further code filter condition according to which a read code is added to the list or discarded. This parameter is available if the Code Filter Depth value is other than zero or if the Code Filter value is Tx Line.

In addition to the inherent content and code length comparison, this parameter compares the X coordinate code position. If the current code being read is identical to any code contained in the list by: content, length and X coordinate code position, the current code is discarded. If not, the current code is accepted and added to the list in the first position; the remaining codes in the list are shifted. If the list is full the oldest code in the list will be flushed.

### Replicate same code when Y positions don't match

Select the check box to enable a further code filter condition according to which a read code is added to the list or discarded. This parameter is available if the Code Filter Depth value is other than zero or if the Code Filter value is Tx Line.

In addition to the inherent content and code length comparison, this parameter compares the Y coordinate code position. If the current code being read is identical to any code contained in the list by: content, length and Y coordinate code position, the current code is discarded. If not, the current code is accepted and added to the list in the first position; the remaining codes in the list are shifted. If the list is full the oldest code in the list will be flushed.

### Replicate same code when Z positions don't match

Select the check box to enable a further code filter condition according to which a read code is added to the list or discarded. This parameter is available if the Code Filter Depth value is other than zero or if the Code Filter value is Tx Line

In addition to the inherent content and code length comparison, this parameter compares the Z coordinate code position. If the current code being read is identical to any code contained in the list by: content, length and Z coordinate code position, the current code is discarded. If not, the current code is accepted and added to the list in the first position; the remaining codes in the list are shifted. If the list is full the oldest code in the list will be flushed.

### Continuous Threshold (number of scans)

Enter an N number of scans without a code allowed in order to assure code identification in the reading zone. Enter a value from 10 to 32665.

See “Encoder Settings” on page 66

## **OPERATING MODEL: PACKTRACK**

Refer to PackTrack in the DS8110 and DX8210 Reference Manuals for physical PackTrack installation procedures.

The screenshot displays a configuration window for the PackTrack operating mode. It is organized into several sections:

- Operating Mode:**
  - Operating Mode Selection: Packtrack (dropdown)
  - Bidirectional PackTrack Enable:
- Trigger Source:**
  - Start Input Number: Trigger (Input 1) (dropdown)
  - Start Input Active Level: Active Closed (dropdown)
  - Transmission Edge: Trailing (dropdown)
- Mode Settings:**
  - Distance from PS Line to Tx Line: 1500 mm (input field)
  - PS Line: 0 mm (input field)
  - Minimum Package Length: 50 mm (input field)
  - Minimum Distance Error Behavior: Compose (dropdown)
  - Minimum Distance Between Packages: 30 mm (input field)
  - Window Dimension: 15 mm (input field)
- Encoder Settings:**
  - Encoder Source: Physical Encoder (Tachor) (dropdown)
  - Encoder Step (hundredths of millimeter): 63 (input field)
- Beam Shutter Settings:**
  - Beam Shutter: Disabled (dropdown)

At the bottom of the window are three buttons: Update All, Reset All, and Reset Page.

### **Trigger Source**

Select the source of the trigger from the drop-down list.

#### Start Input Number

Select the Input Number from the selections available in the drop-down list. Options are; Trigger (Input 1), Aux (Input 3), or I/O 4 (Input 4)

This option defines the numbered input that will start the trigger cycle.

#### Start Input Active Level

Select Active Open or Active Closed from the drop-down list.

**Active Open:** The input is active when there is no current flowing through IN pins. The input from the trigger source is normally closed. The scanner goes into trigger mode when the input source is opened.

**Active Closed:** The input is active when current flows through IN pins. The input from the trigger source is normally opened. The scanner goes into trigger mode

when the input source is closed.

**Transmission Edge**

Select Trailing or Leading from the drop-down list to define the signal edge of the stop input used by the scanner as reference for ending the reading phase:

**Trailing:** The reading phase ends when the pack has completely passed by the stop input.

**Leading:** The reading phase ends as soon as the stop input detects the front edge of the pack.

**Bidirectional PackTrack Settings**

Reverse Start Input	Aux (Input 3)
Reverse Start Input Active Level	Active Closed
Distance from PS to Reverse PS	1500 mm
Direction Input	I/O 4 (Input 4)
Direction Input Active Level	Active Closed
Direction Input Debounce (sec)	0
Direction Message Enable	<input type="checkbox"/>

**Mode Settings**  
**Distance from PS Line to Tx Line**

Enter the distance along the Y axis from the PS (photoelectric sensor) to the TX Line (transmit).

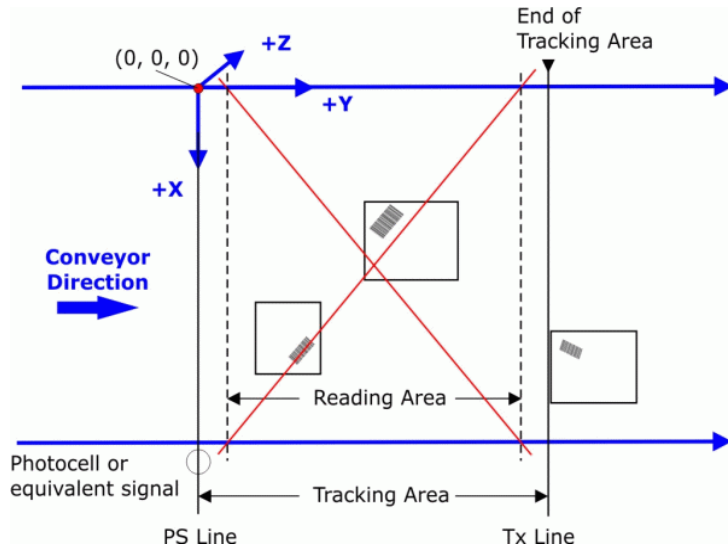

Tracking starts 10 cm [4 inches] before and stops 10 cm [4 inches] after the Reading Area in order to ensure the barcode is assigned to the correct package.

## PS Line

This parameter defines the read signal Y coordinate (mm) referred to the origin of co-ordinates used for PackTrack™ configuration (see below).

Normally the PS Line coincides with the PackTrack reference where X, Y, Z = 0.

If the presence sensor (photocell or Host PS signal) is moved, you must set the PS Line accordingly and recalculate the Tx Line.

1. PS Line = 0; Distance from PS Line to Tx Line = 2500
2. PS Line = 500; Distance from PS Line to Tx Line = 2000

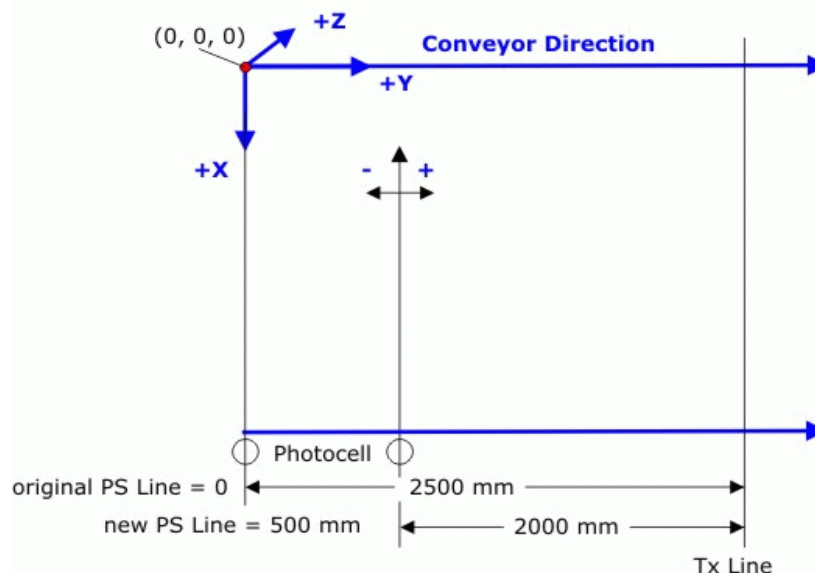

## Minimum Package Length

Enter the minimum length of a pack in the space provided (mm, in).

## Minimum Distance Error Behavior

Select Ignore Error, Compose, or Discard Last from the drop-down list.

**Ignore Error:** the occurred error is ignored

**Compose:** Enter the Minimum Distance Between Packs in the field provided.

**Discard Last:** discards all received packs

## Minimum Distance Between Packages

Enter the minimum distance (mm, in) between consecutive packs. This field is only available when Compose or Discard Last is selected for the Minimum Distance Error Behavior.

## Window Dimension

Enter a Window Dimension in the field provided.

The measurement of a barcode position in absolute coordinates performed by the scanners may be affected by an error. PackTrack™ evaluation can fail in assigning the barcode for this reason. With the Window Dimension parameter, the Y coordinates that delimit the pack can be virtually extended to improve the assigning success rate (see the following figure).

If the minimum distance between two consecutive packs is less than twice the value of the Window Dimension, the window is dynamically resized (dynamic window) to half the distance between the two packs. The code will be assigned within the Window Dimension of the closest pack.

If the minimum distance between two consecutive packs is more than twice the value of the Window Dimension, the code will be assigned within the Window Dimension itself.

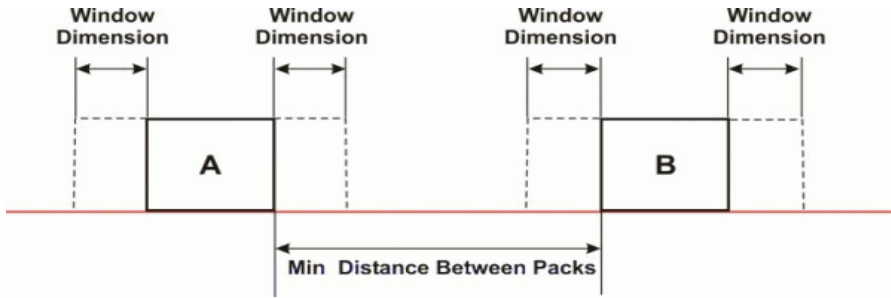

**Encoder Settings**  
**Encoder Source**

Select Constant Speed (Internal), Physical Encoder (Tachometer), or Derived Encoder (PLL) from the drop-down list:

**Constant Speed (Internal):** Allows the user to specify the tach rate to be used (from .05 – 3.05 m/sec [from 10 – 600 ft/min]). No external hardware is used.

**Encoder Settings**

Encoder Source Constant Speed (Intern ▼)

Conveyor Speed (mm/sec)  mm/sec

**Physical Encoder (Tachometer):** A physical encoder is connected to the Encoder input and is enabled.

**Encoder Settings**

Encoder Source Physical Encoder (Tach ▼)

Encoder Step (hundredths of millimeter)

**Derived Encoder (PLL):** determines the encoder rate from an external signal. This is used in applications where the distance between fixed-sized packages/trays is constant.

**Encoder Settings**

Encoder Source Derived Encoder (PLL) ▼

Derived Encoder Input Source Trigger (Input 1) ▼

Derived Encoder Input Edge Rise to Rise ▼

Derived Encoder Input Pulse Width  mm

Encoder Step (hundredths of millimeter)

**Conveyor Speed (mm/sec)**

This parameter is available only when the Physical Encoder is disabled. It defines the constant speed of the conveyor in mm/sec.

**Encoder Step (Hundredths of millimeters)**

Enter the step value of the encoder.

**Encoder Step Settings Table:**

Encoder Model	PPR (Pulses Per Revolution)	PPI (Pulses Per Inch)	Encoder Step Setting
OEK-4 (Dat-alogic)	250	20	63
OEK-2 (Photocraft)	24	2	635
OEK-2	48	4	317
OEK-2	192	16	79
OEK-2	240	20	63



The maximum allowed encoder frequency is 5 kHz (equivalent to an encoder set to 20 PPI with a conveyor speed of 381 m [1250 ft.] /minute).

### **Beam Shutter Settings**

#### **Beam Shutter**

Select Disabled, Enabled, or Triggered from the drop-down list. The Beam Shutter turns the laser off and can be used to increase the overall laser diode life when used in high ambient temperature applications (over 35° C); to reduce power consumption; or to turn off the laser for safety purposes.

- **Disabled:** The laser is always on.
- **Triggered:** The laser is turned off as soon as the code(s) are read or when the reading phase ends. The laser is turned on again when the next reading phase starts
- **Enabled:** The laser is always off and all operations are suspended.

#### **PackTrack Beam Shutter Timeout**

Select a time value from the drop-down list. This parameter is available only when Operating Mode = PackTrack™ and [Beam Shutter](#) = Triggered. By setting this parameter the laser is turned off as soon as the selected timeout expires. The next trigger signal will turn the laser back on.

3. When you have finished making changes, click **Update All** to save all pending changes, click **Reset All** to revert to all previously saved values, and click **Reset Page** to revert to previous saved values on the current page.



## Barcode Settings Table

Use the **Barcode Settings Table** to select and configure the barcodes to be read in your application.

To edit the **Barcode Settings**:

1. In the menu under Modify Settings, navigate to **Global Settings | Barcode Settings**. The Barcode Settings window opens.

Idx	Symbology	Minimum Length	Maximum Length
1	Code 93	8	13
2	Code 128	4	40
3	Interleaved 2 of 5	8	8
4	UPC-A	12	No Add On
5	Disabled		

**Barcode 1**

Enable

Code Symbology

Minimum Label Length

Maximum Label Length

Match String Rule

Pattern Match String

**Options**

Decoding Safety

Decoding Severity

Bar Count

Match Direction Rule

2. Enter the appropriate information in the form as described below:

### Top Panel

Displays a list of barcodes that have been added to the system with the following columns:

#### Idx

Select the Idx for the row/barcode you wish to enter or edit.

If a row is disabled, a barcode type can be selected and configured for that row.

If a barcode type is displayed in the selected row, its configuration can be edited.

#### Symbology

Displays the name of the barcode symbology for that row. If no symbology has been added for a row, disabled is displayed.

#### Minimum Length

Displays the minimum barcode character length for that row's symbology.

#### Maximum Length

Displays the maximum barcode character length for that row's symbology.

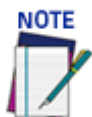

## Barcode n

Input fields will vary depending on the selected symbology. You can set up to 10 bar codes.

### Enable

Select the Enable check box to activate the selected barcode. Deselect the Enable check box to disable the selected barcode. When the check box has been selected, configuration and code type options are displayed

### Code Symbology

Select a barcode symbology from those available in the Code Symbology drop-down list.



### EAN Add On

This options is only available for EAN and UPC options.

Select No Add On, 2 digits Add On, or 5 digit Add On from the EAN Add On drop-down list. Selecting 2 digit Add On or 5 digit Add On adds that many digits as a supplement to the barcode. EAN is the acronym for International Article Number, previously known as European Article Number.

### Minimum Label Length

Enter the minimum character length for the selected barcode. 2D will appear if a 2D code symbology is selected.

### Maximum Label Length

Enter the maximum character length for the selected barcode. 2D will appear if a 2D code symbology is selected.

### Match String Rule

Select Match or Do Not Match from the drop-down list. This parameter defines the matching rule, which defines which codes can be transmitted.

**Match:** All codes matching the Pattern Match String will be transmitted

**Do Not Match:** All codes not matching the Pattern Match String will be transmitted

### Pattern Match String (max. 200 chars)

Click  to activate the Text Entry Tool and create a pattern match string. A code can also be identified by its content. A pattern matching string is programmable for each code.

It is possible to define the matching string by inserting:

all printable characters

\* = defining any string consisting of an undefined number of characters (it may be empty)

? = identifying any character to be found in the position indicated within the string

If your application requires inserting ?, \* and NUL as characters, it is necessary to use the following syntax:

? character = <NUL>?

\* character = <NUL>\*

NUL character = <NUL>00

other extended ASCII characters = <NUL>xy, where xy identifies the character hex value

### Examples:

**Match a code starting with 123 string and followed by any string of characters:**

Match String = 123\*

Example Code = 123aC53

**Match a code ending with 123 string preceded by any string of characters:**

Match String = \*123

Example Code = 41pO123

**Match a code having 123 string in any position:**

Match String = \*123\*

Example Code = 41pO123253

**Match a code starting with 123 string followed by three generic characters and an undefined string of characters, in this case no character:**

Match String = 123???\*

Example Code = 123ad2

**Match any code of four characters:**

Match String = ????

Example Code = gT6k

**Match a code with 6 characters in any position having 12 as central characters:**

Match String = \*??12??\*

Example Code = data12og35

**The following is an example of a very complex string where ? and\* are used both as commands and as characters:**

Match String = \*45<NUL>??\*??AC<NUL>\*251?\*

Example Code = GEN45?3iusdsAC\*2516300



**For Codabar codes the start/stop characters must be considered in the match conditions. For all codes which use check digits, if the Check Digit is transmitted, it must be considered in the match conditions.**



**Input fields will vary depending on the selected symbology.**

**OPTIONS**  
**Code 128**

<b>Options</b>	
Decoding Safety	<input type="text" value="1"/>
Decoding Severity	<input type="text" value="3"/>
Bar Count	<input type="text" value="Variable"/>
Match Direction Rule	<input type="text" value="Disable"/>
Remove Function Characters	<input checked="" type="checkbox"/>

**GS1-128(EAN128), Code 93**

<b>Options</b>	
Decoding Safety	<input type="text" value="1"/>
Decoding Severity	<input type="text" value="3"/>
Bar Count	<input type="text" value="Variable"/>
Match Direction Rule	<input type="text" value="Forward"/>



**Contact Datalogic Technical Support before modifying the Decoding Safety or Decoding Severity parameters.**

**Decoding Safety**

Enter a number from 1 to 100 (1 = control disabled) in the field provided. It verifies that an N number of decodes are performed with the same result before code reading is accepted as valid. Only available when Reading Mode is Linear.

**Decoding Severity**

Enter a number from 1 to 5 (1 = lowest severity level and 5 = highest severity level). During decoding poorly printed or damaged codes can be discarded because they do not match the expected code. The Decoding Severity defines a ratio between the actual and the expected code image. The lower the ratio, the higher the difference between images. Setting a low value increases the possibility for decoding errors.

### Bar Count

Select Variable or an available value from the drop-down list. The Bar Count allows you to further specify the number of elements in the read code for Code 128, GS1-128, Code 93, ISBT 128 or Code 39 Full ASCII. For these codes, the same number of barcode elements (bars + spaces) can be associated with a different number of characters.

**Variable:** to select the correct number of characters, set Label Length to the desired fixed value and Bar Count to Variable



**Code 128 or GS1-128:** from 25 to 499 – a variable number of characters in steps of 6.

**Code 93 or ISBT 128:** from 25 to 385 – a variable number of characters in steps of 6.

**Code 39 Full ASCII:** from 29 to 619 – a variable number of characters in steps of 10.

To select a particular barcode length in elements, set Bar Count to the desired fixed value and Label Length to Variable.



### Match Direction Rule

Select Disable, Forward, or Reverse from the drop-down list. This parameter defines the direction, according to which a code can be transmitted. The direction refers to the code direction with respect to the scan line, in particular: Forward = the code start character precedes the stop character in the scan line (Start Ch + Code + Stop Ch); Reverse = the code stop character precedes the start character in the scan line (Stop Ch + Code + Start Ch)

**Disable:** All codes are transmitted no matter what the direction is

**Forward:** All codes having a forward direction are transmitted

**Reverse:** All codes having a reverse direction are transmitted

### Remove Function Characters

Select the check box to remove functional characters.

**Interleaved 2 of 5, Code 39**

Options	
Decoding Safety	<input type="text" value="1"/>
Decoding Severity	<input type="text" value="3"/>
Check Digit	<input type="checkbox"/>
Match Direction Rule	Forward ▼

**WARNING**

Contact Datalogic Technical Support before modifying the Decoding Safety or Decoding Severity parameters.

**Decoding Safety**

Enter a number from 1 to 100 (1 = control disabled) in the field provided. It verifies that an N number of decodes are performed with the same result before code reading is accepted as valid. Only available when Reading Mode is Linear.

**Decoding Severity**

Enter a number from 1 to 5 (1 = lowest severity level and 5 = highest severity level). During decoding poorly printed or damaged codes can be discarded because they do not match the expected code. The Decoding Severity defines a ratio between the actual and the expected code image. The lower the ratio, the higher the difference between images. Setting a low value increases the possibility for decoding errors.

**Check Digit**

Select the check box to improve decoding safety: it is generally the last digit aligned to the right of the code and verifies the validity of the preceding digits. The calculation technique and number of check digits depend on the code selected.

It is advised to enable the check digit whenever correct code identification is difficult.

**Match Direction Rule**

Select Disable, Forward, or Reverse from the drop-down list. This parameter defines the direction, according to which a code can be transmitted. The direction refers to the code direction with respect to the scan line, in particular: Forward = the code start character precedes the stop character in the scan line (Start Ch + Code + Stop Ch); Reverse = the code stop character precedes the start character in the scan line (Stop Ch + Code + Start Ch)

**Disable:** All codes are transmitted no matter what the direction is

**Forward:** All codes having a forward direction are transmitted

**Reverse:** All codes having a reverse direction are transmitted

**EAN-13, EAN-8, UPC-A, UPC-E, All EAN-UPC, Aztec, DataMatrix, Maxicode**

Options	
Decoding Safety	<input type="text" value="1"/>
Decoding Severity	<input type="text" value="3"/>
Match Direction Rule	<input type="text" value="Forward"/>

**WARNING**

Contact Datalogic Technical Support before modifying the Decoding Safety or Decoding Severity parameters.

**Decoding Safety**

Enter a number from 1 to 100 (1 = control disabled) in the field provided. It verifies that an N number of decodes are performed with the same result before code reading is accepted as valid. Only available when Reading Mode is Linear.

**Decoding Severity**

Enter a number from 1 to 5 (1 = lowest severity level and 5 = highest severity level). During decoding poorly printed or damaged codes can be discarded because they do not match the expected code. The Decoding Severity defines a ratio between the actual and the expected code image. The lower the ratio, the higher the difference between images. Setting a low value increases the possibility for decoding errors.

**Match Direction Rule**

Select Disable, Forward, or Reverse from the drop-down list. This parameter defines the direction, according to which a code can be transmitted. The direction refers to the code direction with respect to the scan line, in particular: Forward = the code start character precedes the stop character in the scan line (Start Ch + Code + Stop Ch); Reverse = the code stop character precedes the start character in the scan line (Stop Ch + Code + Start Ch)

**Disable:** All codes are transmitted no matter what the direction is

**Forward:** All codes having a forward direction are transmitted

**Reverse:** All codes having a reverse direction are transmitted

**Codabar**

Options	
Decoding Safety	<input type="text" value="1"/>
Decoding Severity	<input type="text" value="3"/>
Check Digit	<input type="checkbox"/>
Match Direction Rule	<input type="text" value="Forward"/>
Start Char Tx	<input type="text" value="Disabled"/>
Stop Char Tx	<input type="text" value="Disabled"/>

**WARNING**

Contact Datalogic Technical Support before modifying the Decoding Safety or Decoding Severity parameters.

**Decoding Safety**

Enter a number from 1 to 100 (1 = control disabled) in the field provided. It verifies that an N number of decodes are performed with the same result before code reading is accepted as valid. Only available when Reading Mode is Linear.

**Decoding Severity**

Enter a number from 1 to 5 (1 = lowest severity level and 5 = highest severity level). During decoding poorly printed or damaged codes can be discarded because they do not match the expected code. The Decoding Severity defines a ratio between the actual and the expected code image. The lower the ratio, the higher the difference between images. Setting a low value increases the possibility for decoding errors.

### Check Digit

Select the check box to improve decoding safety: it is generally the last digit aligned to the right of the code and verifies the validity of the preceding digits. The calculation technique and number of check digits depend on the code selected.

It is advised to enable the check digit whenever correct code identification is difficult.

### Match Direction Rule

Select Disable, Forward, or Reverse from the drop-down list. This parameter defines the direction, according to which a code can be transmitted. The direction refers to the code direction with respect to the scan line, in particular: Forward = the code start character precedes the stop character in the scan line (Start Ch + Code + Stop Ch); Reverse = the code stop character precedes the start character in the scan line (Stop Ch + Code + Start Ch)

**Disable:** All codes are transmitted no matter what the direction is

**Forward:** All codes having a forward direction are transmitted

**Reverse:** All codes having a reverse direction are transmitted

### Start/Stop Char Tx (Specific to Codabar)

Select Disabled, Lower Case, or Upper Case from the drop-down list. This parameter is available only for Codabar code symbologies. It allows transmitting the code start/stop character:

**Disabled:** The character is not selected;

**Lower Case:** The character is transmitted in lower case;

**Upper Case:** The character is transmitted in upper case.

3. When you have finished making changes, click **Update All** to save all pending changes, click **Reset All** to revert to all previously saved values, and click **Reset Page** to revert to previous saved values on the current page.



## Barcode Configuration

Use **Barcode Configuration** to configure how the system defines a no read barcode, and configure and filter NOREAD messages.

To edit the **Barcode Configuration**:

1. In the menu under **Modify Settings**, navigate to **Global Settings | Barcode Configuration**. The **Barcode Configuration** window opens.

### Code Combination

Select Single Label, Standard Multi Label, Logical Combination, or Code Collection from the drop-down list. The Code Combination parameter selects the decoding mode for the scanner.

**Single Label** “Single Label” on page 79: In this mode only one barcode can be read in each reading phase; however it can be determined automatically from up to 10 enabled codes. The scanner stops decoding as soon as a code is read.

If the code is not read during the reading phase, the No Read message is produced.

**Standard Multi Label** “Barcode Configuration | Standard Multi Label” on page 78: In Multi Label mode the barcodes selected (up to 10), will all be read in the same reading phase. If the reading phase terminates before all the codes are read, a Global No Read message will be produced, unless it is disabled, in which case a Local No Read will be produced.



**In case of Multi Label, the codes will be distinguished EITHER by their symbology, OR by their contents. If two (or more) codes share the same symbology and same content, the scanner will perceive them as the same code.**

**Logical Combination** “Barcode Configuration | Logical Combination” on page 82: In Logical Combination mode the codes of the groups defined by the Logical Combination Rule are read in the same reading phase.

**Code Collection** “Barcode Configuration | Code Collection” on page 97: In Code Collection mode expected codes are collected within a single reading phase in the order in which they are read. The No Read message is produced only if none of the codes are read. Up to 50 codes can be collected.

## Understanding Barcode Configurations

Each barcode configuration code combination handles no read options differently. Below is an explanation of how they are handled.

### No Read Messages

The **Barcode Settings Table** allows you to setup what types of barcodes will be decoded. You can set up to 10 bar codes. In the following example, four bar codes have been set.

**Barcode Settings**

Idx	Symbology	Minimum Length	Maximum Length
<input checked="" type="radio"/> 1	Code 93	8	13
<input type="radio"/> 2	Code 128	4	40
<input type="radio"/> 3	Interleaved 2 of 5	8	8
<input type="radio"/> 4	UPC-A	12	No Add On
<input type="radio"/> 5	Disabled		

**Barcode 1**

Enable

Code Symbology

Minimum Label Length

Maximum Label Length

Match String Rule

Pattern Match String

Code Label Local No Read String

Barcode Configuration allows you to set up what will be transmitted once barcodes are read. You may read one or more barcode labels on a package at a time.

Global and Local No Read settings are available, as well as filter settings to reduce duplicate reading messages.

There are four Code Combination options: Single Label, Standard Multi Label, Logical Combination and Code Collection.

### Single Label Local No Read Message

In the Barcode Settings Table, four bar codes have been enabled; Code 93, Code 128, I 2of5, and UPC-A. Only one bar code can be read in each reading phase, the first code read successfully is transmitted. If no codes are read a Global No Read message is transmitted.

**Barcode Configuration**

Code Combination

No Read Message

Use 'Global No Read String' when No Codes Read

Global No Read String

Multi Filters

Local No Read cannot be selected for Single Label configurations.

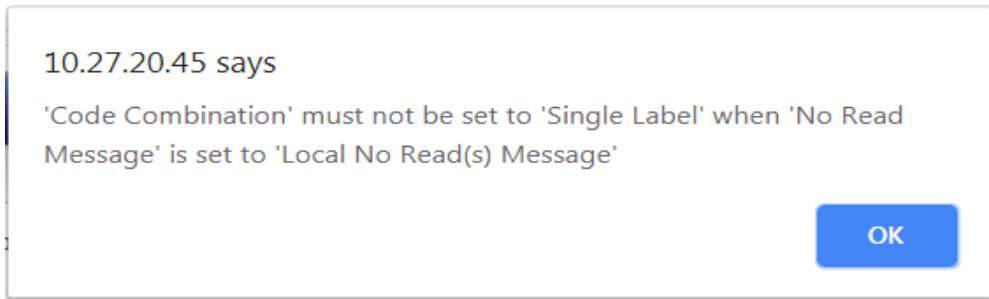

**Single Label Global No Read Message**

The Global No Read Message must be selected.

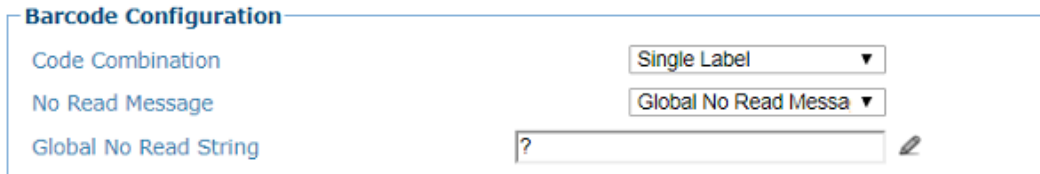

The same four bar codes have been enabled in the Barcode Settings Table and the first code decoded is transmitted: #STX675898767566#CR#LF. If no codes are read the Global No Read String is transmitted: #STX??????#CR#LF

**Standard Multi Label Local No Read Message**

Assuming the same four bar codes have been enabled in the Barcode Settings Table, we now select the Standard Multi Label Code Combination. This specifies that all of the bar codes may be read during the reading phase. If Local No Read Message is selected, a no read message is defined for each of the barcodes in the Barcode Settings Table.

When local no read is selected the No Read string is entered in the barcode settings table.

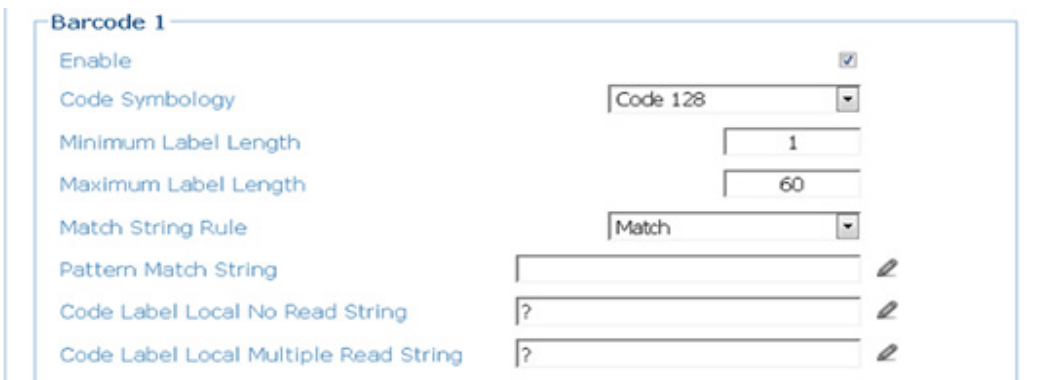

Let’s assume two of the enabled codes were read and two were not, the message is transmitted as: #STX?,1234567890123,?,675898767566#CR#LF

This indicates that the first and third codes enabled did not read while the second and fourth did.

The multiple label options needs to be identified in the standard multi-label option.

### Standard Multi Label Global No Read Message

Again the same four bar codes have been enabled in the Barcode Settings Table, and the Standard Multi Label Code Combination has been selected. However this time we select a Global No Read Message.

**Barcode Configuration**

Code Combination	Standard Multi Label
No Read Message	Global No Read Messa
Global No Read String	??????
Multiple Read Message	Enable
Multiple Read String	?
Multi Filters	<input checked="" type="checkbox"/>

All 4 codes must be read during the trigger cycle.

```
STX0027110002054872550918034976966,1234567890123,0467,675898767566#CR#LF
```

If all four codes are not read a single No Read message is transmitted:

```
#STX???????#CR#LF
```

### Logical Combination Local No Read

As before four codes have been enabled. Four code groups have been defined and a logical combination rule states that code 1 and 2 and 3 and 4 must be read. Each one of the four codes is assigned to its own group. Local No Read Message is selected and a no read string is defined for each code. In this example the second code has not been read. Each group contains 1 possible code.

The transmitted message might look like this:

```
STX0027110002054872550918034976966,?,0467,675898767566#CR#LF
```

This identifies that a no read message for the 2nd group, 2nd code has occurred.

### Code Collection Global No Read

3 of the 4 codes enabled are read. Any number of codes read is transmitted. Only if all of the codes are not read is there a no read and it must be a Global No Read. The transmitted message might look like this:

```
#STX0027110002054872550918034976966,1234567890123,675898767566#CR#LF
```

## Single Label

When **Single Label** has been selected from the **Code Combination** drop-down list, the Barcode Configuration window reveals related input fields.

1. Enter the appropriate information in the form as described below:

### Code Combination – Single Label has been selected. No Read Message

Select Disable No Read Message, Global No Read Message, or Local No Read(s) Message from the drop-down list. The No Read condition occurs whenever a code cannot be read or decoded.

**Disable No Read Message:** The No Read Message is not transmitted.

**Global No Read Message:** The [No Read String](#) will be sent if the scanner is unable to decode one or more barcodes in the reading phase.

The Global No Read String is sent if none of the bar codes in the bar codes settings table are read. When any one of the bar cods in the table are read, then the local no read is used; if no bar codes are read then the Global No Read Message is transmitted if the options is selected.

**Local No Read(s) Message:** Do not use this option when working in Single Label mode. The Local No Read Message uses a not read message for each code selected. With the Standard Multi Label and Code Collection option the Local No Read messaged is defined in the barcode settings table located under the individual bar code option the local no read message is defined on the bar code configuration page. There is no local no read message in the single label option.

### Use 'Global No Read String' when No Codes Read

Select the check box to allow the Global No Read String to be used if no codes at all are read. This option is not available when Global No Read Message is selected from the No Read Message drop-down list.

### Global No Read String (max. 128 chars)

Click  to activate the Text Entry Tool and create a string to be displayed when Global No Read Message is selected from the No Read Message drop-down list.



**These filter options are provided to eliminate false multiple reads.**

### Multi Filters

Select the check box to display the Multi-Filter Settings options.

### **Multi-Filter Settings**

### Contained Filter

Select the check box to reveal the **Max Number of Different Characters** field.

When checked, this filter attempts to eliminate false multiple reads by determining if a short code read is "contained in" (is a sub-string of), another longer code read.

This condition implicates that the short code is probably a misread of the same longer code and therefore should be ignored, (should not be considered as a multiple read of a different code).

This filter is based upon the following rules:

a multiple read condition occurs

all decoded codes of the same type are compared with each other

**Rule 1:** the shorter code is considered contained in the longer code if the character string is found in the same order; the longer code may have a single block of characters in any position (before, after or in between the compared strings)

**Example:** The code 123456 is considered contained in the following codes: 00123456, 12345600, 12378456.

The code 123456 is not considered contained in the following codes: 12346507 (string out of order), 12345700 (string not complete), 120378456 or 0012345600 (multiple blocks in the string).

**Rule 2:** the shorter code is not filtered by rule 1. In the longer code, all possible sub-strings of the same length as the shorter code string are compared with the shorter code string. The shorter code is considered contained in the longer code if the number of different characters between the compared codes is less than or equal to the Max Number of Different Characters. The shorter code will be filtered by rule 2.

**Example:**

If Max Number of Different Characters = 1:

The code 123456 is considered contained in the following codes: 12305600, 00123056, 8812305688 because there is only one different character in the compared string.

The code 123456 is not considered contained in 123066789 because there are two different characters in the compared string.



**If the Contained Filter parameter is used when [Message Tx Selection](#) (see section "Special Host Protocol: None" on page 136) is set to On Decoding, the filter conditions may be satisfied before the reading phase ends resulting in possible successive multiple read errors.**

### **Max Number of Different Characters**

Enter a value from 0 to 5 in the field provided to define the maximum number of different characters allowed to still consider a code as being included in another code and therefore to be filtered.

If the number of different characters between the compared codes exceeds the value of this parameter, the codes are considered as different and will not be filtered (a multiple read of a different code occurs).

If the number of different characters between the compared codes is less than or equal to the value of this parameter, the short code is considered as a sub-string of the longer code and will be filtered (no multiple read occurs).

**Examples:**

If Max Number of Different Characters = 2:

The code 123456 read once, is considered the same as the following codes read multiple times: 133056, 123546, 123457 because there are two or less different characters by position in the compared codes.

The code 123456 read once, is not considered the same as the following codes read multiple times: 153246, 103057, 654321 because there are at least three different characters by position in the compared codes.

### **Voting Filter**

Select the check box to reveal the [Max Number of Different Characters](#) field.

When checked, this filter attempts to eliminate false multiple reads by comparing the number of different characters by position between two codes of the same type and length. This condition implicates that reading a code of the same type and length having very few different characters is probably a misread of the code itself and therefore the code read the least number of times should be ignored, (should not be considered as a multiple read of a different code).

This filter is based upon the following rules:

a multiple read condition occurs;  
 the two codes are of the same type;  
 the two codes have the same length;  
 the number of different characters by position is equal to or less than the number defined by the [Max Number of Different Characters](#) parameter;  
[Message Tx Selection](#) (see section “Special Host Protocol: None” on page 136) must be set to After Reading Phase Off.

### **Filter Out Low Height Codes**

Select the check box to reveal the **Minimum Readings Difference Between Scanners** field.

Background: This option was developed for the airports systems where there are often tall bar height codes and low bar height codes with the same content attached to baggage. Travelers will often remove the large, tall bar height code, while leaving the smaller, low bar height codes attached to the bag. The next time they travel they may have multiple low bar height codes on their baggage plus the new tall bar height and low bar height codes for the new trip.

This option instructs the system to ignore low bar height codes, which are likely read only once or twice, in favor of tall bar height codes, which will likely be read multiple times.

This is used in tunnel applications where multiple barcodes are read and there is a need to filter out one of the barcodes. If less than x number of scanners read the barcode, then it will be considered a NOREAD for that code.

### **Minimum Readings Difference Between Scanners**

Enter the minimum number of scanners that must read a barcode for it to be considered a valid read.

### **Filter Out Single Readings**

If only 1 scanner reads a code it will be considered a NOREAD>

### **Strip Filter**

Select the check box to display the Strip Filter Settings options. This is a second level filter that eliminates characters not managed or needed by the host.

### **Strip Filter Settings**

### **Strip All Non Printable Chars**

Select the check box to remove all non- printable ASCII characters from the code (000-020 and 127).

### **Char(s) to be Stripped**

Click to activate the “Entering Text Using the Text Entry Tool” on page 47 and enter specific characters to be stripped from the code. Click Submit to save your text to the origin window text field, or click Cancel to return to origin window without transferring text.

### **Strip Filter Collapse**

Select the check box to remove the stripped characters from the code and, therefore, reduce the code length (collapsed). It can even be null.

### **Replacement Char**

Click to activate the “Entering Text Using the Text Entry Tool” on page 47 and enter the substitution character to replace all the stripped ones. Click Submit to save your text to the origin window text field, or click Cancel to return to origin window without transferring text.



2. When you have finished making changes, click **Update All** to save all pending changes, click **Reset All** to revert to all previously saved values, and click **Reset Page** to revert to previous saved values on the current page.

## Standard Multi Label

When **Standard Multi Label** has been selected from the **Code Combination** drop-down list, the Barcode Configuration window reveals related input fields.



In case of Multi Label, the codes will be distinguished EITHER by their symbology, OR by their contents. If two (or more) codes share the same symbology and content, the scanner will not perceive them as a unique code.

1. Enter the appropriate information in the form as described below:

### Code Combination – Standard Multi Label has been selected. No Read Message

Select Disable No Read Message, Global No Read Message, or Local No Read(s) Message from the drop-down list. The No Read condition occurs whenever a code cannot be read or decoded.

**Disable No Read Message:** The No Read Message is not transmitted.

**Global No Read Message:** The No Read String will be sent if the scanner is unable to decode one or more barcodes in the reading phase.

**Local No Read(s) Message:** This option is useful when one or more codes are not read in the reading phase or when more codes than the expected number set by the configuration parameters are read.

If working in Standard Multi Label mode, this option activates the Code Label Local No Read String and the Code Label Local Multiple Read String parameters which allow setting a Local No Read String and a Local Multiple string in the Barcode Settings Table for each defined code symbology.

### Use 'Global No Read String' when No Codes Read

Select the check box to allow the Global No Read String to be used if no codes at all are read. This option is not available when Global No Read Message is selected from the No Read Message drop-down list.

### Global No Read String (max. 128 chars)

Click  to activate the Text Entry Tool and create a string to be displayed when Global No Read Message is selected from the No Read Message drop-down list. Click Submit to save your text to the origin window text field, or click Cancel to return to origin window without transferring text.



These filter options are provided to eliminate false multiple reads.

### Multiple Read Message

Select Disable or Enable from the drop-down list. This string will be sent if, during the reading phase, the scanner reads more than the number of the expected barcodes set by the configuration parameters.

**Multiple Read String (max. 128 chars)**

Click  to activate the Text Entry Tool and create a string to be displayed in case of Multiple Read Message. Click Submit to save your text to the origin window text field, or click Cancel to return to origin window without transferring text.

This parameter is only available when Multiple Read Message is enabled and the No Read Message selection is different from Local No Read(s) String. It is possible to select either the ASCII or HEX value. If disabled, the scanner transmits the first code read.

**Send All Multiple Read Labels**

Select Enable or Disable. For Advanced Data Formats only, by enabling this parameter all multiple read labels will be included in the output message. They can be separated by the Multiple Read Separator.

**Multiple Read Label Separator String (max. 128 chars):**

The Multiple Read Label Separators (up to 128 bytes) are used to separate multiple read barcodes in the reading phase.

This is meaningful when the Code Combination parameter is set to Multi Label or Logical Combination and the Send All Multiple Read Labels parameter has been enabled.

If selected, they occur within the Code Field and are transmitted after each decoded multiple read barcode.

**Multi Filters**

Select the check box to display the Multi-Filter Settings options.

**Multi-Filter Settings**

Multi-Filter Settings	
Contained Filter	<input type="checkbox"/>
Voting Filter	<input type="checkbox"/>
Filter Out Low Height Codes	<input type="checkbox"/>
Strip Filter	<input type="checkbox"/>
Priority Filter Enable	<input type="checkbox"/>

**Contained Filter**

Select the check box to reveal the [Max Number of Different Characters](#) field.

When checked, this filter attempts to eliminate false multiple reads by determining if a short code read is "contained in" (is a sub-string of), another longer code read. This condition implicates that the short code is probably a misread of the same longer code and therefore should be ignored, (should not be considered as a multiple read of a different code).

This filter is based upon the following rules:

a multiple read condition occurs

all decoded codes of the same type are compared with each other

Rule 1: the shorter code is considered contained in the longer code if the character string is found in the same order; the longer code may have a single block of characters in any position (before, after or in between the compared strings)

Example: The code 123456 is considered contained in the following codes: 00123456, 12345600, 12378456.

The code 123456 is not considered contained in the following codes: 12346507 (string out of order), 12345700 (string not complete), 120378456 or 0012345600 (multiple blocks in the string).

Rule 2: the shorter code is not filtered by rule 1. In the longer code, all possible sub-strings of the same length as the shorter code string are compared with the shorter code string. The shorter code is considered contained in the longer code if the number of different characters between the compared codes is less than or equal to the Max Number of Different Characters. The shorter code will be filtered by rule 2.

Example:

If Max Number of Different Characters = 1:

The code 123456 is considered contained in the following codes: 12305600, 00123056, 8812305688 because there is only one different character in the compared string.

The code 123456 is not considered contained in 123066789 because there are two different characters in the compared string.

CAUTION: If the Contained Filter parameter is used when Message Tx Selection (see section “Special Host Protocol: None” on page 136 ) is set to On Decoding, the filter conditions may be satisfied before the reading phase ends resulting in possible successive multiple read errors.

### **Max Number of Different Characters**

Enter a value from 0 to 5 in the field provided to define the maximum number of different characters allowed to still consider a code as being included in another one and therefore to be filtered.

If the number of different characters between the compared codes exceeds the value of this parameter, the codes are considered as different and will not be filtered (a multiple read of a different code occurs).

If the number of different characters between the compared codes is less than or equal to the value of this parameter, the short code is considered as a sub-string of the longer code and will be filtered (no multiple read occurs).

Examples:

If Max Number of Different Characters = 2:

The code 123456 read once, is considered the same as the following codes read multiple times: 133056, 123546, 123457 because there are two or less different characters by position in the compared codes.

The code 123456 read once, is not considered the same as the following codes read multiple times: 153246, 103057, 654321 because there are at least three different characters by position in the compared codes.

### **Voting Filter**

Select the check box to reveal the [Max Number of Different Characters](#) field.

When selected, this filter attempts to eliminate false multiple reads by comparing the number of different characters by position between two codes of the same type and length. This condition implicates that reading a code of the same type and length having very few different characters is probably a misread of the code itself and therefore the code read the least number of times should be ignored, (should not be considered as a multiple read of a different code).

This filter is based upon the following rules:

a multiple read condition occurs;

the two codes are of the same type;

the two codes have the same length;

the number of different characters by position is equal to or less than the number defined by the [Max Number of Different Characters](#) parameter;

[Message Tx Selection](#) (see section “Special Host Protocol: None” on page 136 ) must be set to After Reading Phase Off.

### **Filter Out Low Height Codes**

Select the check box to reveal the Minimum Readings Difference Between Scanners field.

Background: This option was developed for the airports systems where there are often tall bar height codes and low bar height codes with the same content attached to baggage. Travelers will often remove the large, tall bar height code, while leaving the smaller, low bar height codes attached to the bag. The next time they travel they may have multiple low bar height codes on their baggage plus the new tall bar height and low bar height codes for the new trip. This option instructs the system to ignore low bar height codes, which are likely read only once or twice, in favor of tall bar height codes, which will likely be read multiple times.

This is used in tunnel applications where multiple barcodes are read and there is a need to filter out one of the barcodes. If less than x number of scanners read the barcode, then it will be considered a NOREAD for that code.

### **Minimum Readings Difference Between Scanners**

Enter the minimum number of scanners that must read a barcode for it to be considered a valid read.

### Filter Out Single Readings

With the check box selected, if only 1 scanner reads a code it will be considered a NOREAD.

### Strip Filter

Select the check box to display the Strip Filter Settings options. This is a second level filter that when enabled allows eliminating characters not managed by the host.

### **Strip Filter Settings**



### Strip All Non Printable Chars

Select the check box to remove all non- printable ASCII characters from the code (000-020 and 127).

### Char(s) to be Stripped

Click  to activate the *“Entering Text Using the Text Entry Tool”* on page 47 and enter specific characters to be stripped from the code. Click Submit to save your text to the origin window text field, or click Cancel to return to origin window without transferring text.

### Strip Filter Collapse

Select the check box to remove the stripped characters from the code and, therefore, reduce the code length (collapsed). It can even be null.

### Replacement Char

Click  to activate the *“Entering Text Using the Text Entry Tool”* on page 47 and enter the substitution character to replace all the stripped ones. Click Submit to save your text to the origin window text field, or click Cancel to return to origin window without transferring text.

2. When you have finished making changes, click **Update All** to save all pending changes, click **Reset All** to revert to all previously saved values, and click **Reset Page** to revert to previous saved values on the current page.

## Logical Combination

When **Logical Combination** has been selected from the Code Combination drop-down list, the Barcode Configuration window reveals related input fields.

The screenshot displays the 'Barcode Configuration' window with the following settings:

- Code Combination:** Logical Combination (dropdown)
- Logical Combination Rule:** 1^2 (text input with edit icon)
- No Read Message:** Local No Read(s) Mes (dropdown)
- Use 'Global No Read String' when No Codes Read:**
- Global No Read String:** ? (text input with edit icon)
- Multiple Read Message:** Enable (dropdown)
- Group No Read Messages:**
  - Group 1 No Read String:** NoRead (text input with edit icon)
- Group Multiple Read Messages:**
  - Group 1 Multiple Read String:** ? (text input with edit icon)
- Multi Filters:**
- Multi-Filter Settings:**
  - Contained Filter:**
  - Maximum Number of Different Characters:** 0 (text input)
  - Voting Filter:**
  - Maximum Number of Different Characters:** 2 (text input)
  - Filter Out Low Height Codes:**
  - Minimum Readings Difference Between Scanners:** 2 (text input)
  - Filter Out Single Readings:**
  - Strip Filter:**
  - Strip Filter Settings:**
    - Strip All Non Printable Chars:**
    - Char(s) to be Stripped:** (text input with edit icon)
    - Strip Filter Collapse:**
    - Replacement Char:** # (text input with edit icon)
- Priority Filter Enable:**
- Priority Filter Group List:** 1 (text input)
- Priority Filter Type:** Advanced (dropdown)
- Priority Filter Advanced String:** (text input)

Buttons at the bottom: Update All, Reset All, Reset Page

1. Enter the appropriate information in the form as described below:

### Code Combination

Logical Combination has been selected.

### Logical Combination Rule

Click  to activate the **code group** selection dialog box.

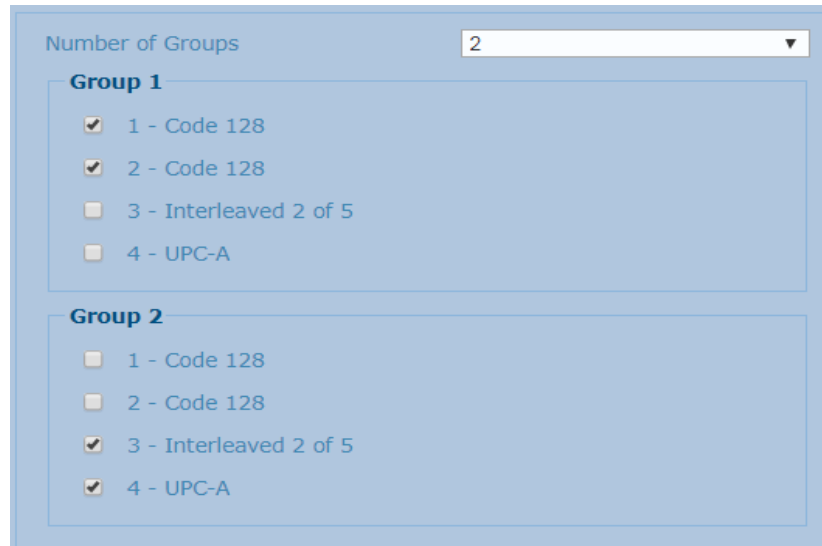

Number of Groups: 2

**Group 1**

- 1 - Code 128
- 2 - Code 128
- 3 - Interleaved 2 of 5
- 4 - UPC-A

**Group 2**

- 1 - Code 128
- 2 - Code 128
- 3 - Interleaved 2 of 5
- 4 - UPC-A

Select the number of groups you wish to use from the Number of Groups drop-down list. Then select the check box next to the Groups/Codes you wish to define. Click Submit to save your selections, or click Cancel to return to the origin window without saving.

The Group order defines the output message sequence, while each group identifies an expected codes within the selected group.

When editing the logical combination rule, proceed as follows:

1. Define the [Barcode Settings](#) indicating the type of expected code labels. It is possible to define up to 10 different code types; These codes should be selected in the Barcode Settings Table before Logical Combination is configured.

2. Define how many code types (groups) are expected by editing the combination rule through the following logical operators. Each group may include one or more selected code types.

& = AND operator which separates a group from the previous/following one;  
^ = XOR operator to be used to combine different code labels within the same group. It allows reading one of the defined code labels.

The maximum number of groups to be defined for each rule string is 15.

If Local No Read Message is selected from the No Read Message drop-down list, the Group No Read Messages parameter is displayed. Define a Local No Read String for each group.



**Examples: Logical Combination Rule**

For all the following examples the No Read Message parameter is set to Global No Read Message.

**Example 1**

Code label setting#1 = Code 128

Logical Combination Rule = 1&1

Defines 2 groups, each of them expecting a Code 128 label.

Decoded Code Symbology		Output Message
First Label #1	Second Label #1	
---	---	<Header><Global No Read Message><Terminator>
X	---	<Header><Global No Read Message><Terminator>
---	X	<Header><Global No Read Message><Terminator>
X	X	<Header><Code 128 data><Data Packet Separator><Code 128 data><Terminator>



If **Multiple Read Message** is enabled and a third label belonging to the Code 128 symbology is decoded, the Multiple Read string is transmitted instead. If the Multiple Read Message is disabled, the third code label is ignored and only the first two codes are transmitted.

For advanced formatting, if the Send All Multiple Read Labels parameter is enabled, then all three labels are sent in the output message; the multiple read label is separated by its own Multiple Read Label Separator String which should be different from the Data Packet Separator (DPS).

**Example 2**

Code label setting#1 = Code 39

Code label setting#2 = Code 128

Logical Combination Rule = 1^2

Defines a single group expecting a Code 128 label OR a Code 39 label.

Decoded Code Symbology		Output Message
Label #1	Label #2	
---	---	<Header><Global No Read Message><Terminator>
X	---	<Header><Code 39 data><Terminator>
---	X	<Header><Code 128 data><Terminator>
X	X	<Header><First decoded code/Multiple Read Message string><Terminator>

**Example 3**

Code label setting#1 = EAN 8

Code label setting#2 = UPC-A

Logical Combination Rule = 1&1&1^2

Defines three different groups. The first two groups expect an EAN 8 label while the third one expects an EAN 8 label OR an UPC-A label.

Decoded Code Symbology				Output Message
First Label #1	Second Label #1	Third-Label #1	Label #2	
---	---	---	---	<Header><Global No Read Message><Terminator>
X	---	---	---	<Header><Global No Read Message><Terminator>
---	X	---	---	<Header><Global No Read Message><Terminator>
---	---	X	---	<Header><Global No Read Message><Terminator>
---	---	---	X	<Header><Global No Read Message><Terminator>
X	X	X	---	<Header><EAN 8 data><DPS><EAN 8 data><DPS><EAN 8 data><Terminator>
X	X	---	X	<Header><EAN 8 data><DPS><EAN 8 data><DPS><U{PD-A data}<Terminator>
X	X	X	X	<Header><EAN 8 data><DPS><EAN 8 data><DPS><First decoded code/Multiple Read Message string><Terminator>

**Example 4**

Code label setting#1 = Code 93

Code label setting#2 = Interleaved 2/5

Code label setting#3 = EAN-8

Code label setting#4 = UPC-A

Logical Combination Rule = 1^2&3^4

Defines 2 groups, each of them expecting one of the defined code types. The first group may expect a Code 93 label or an Interleaved 2/5 label. The second group may expect an EAN-8 label or an UPC-A label.

Decoded Code Symbology				Output Message
Label #1	Label #2	Label #3	Label #4	
---	---	---	---	<Header><Global No Read Message><Terminator>
X	---	---	---	<Header><Global No Read Message><Terminator>
---	X	---	---	<Header><Global No Read Message><Terminator>
---	---	X	---	<Header><Global No Read Message><Terminator>
---	---	---	X	<Header><Global No Read Message><Terminator>
X	X	---	---	<Header><Global No Read Message><Terminator>
X	---	X	X	<Header><Code93><DPS>< First decoded code/Multiple Read Message string><Terminator>
X	X	X	---	<Header><First decoded code/Multiple Read Message string><DPS><EAN 8 data><Terminator>
---	X	X	X	<Header>< Interleaved 2/5 data><DPS>< First decoded code/Multiple Read Message string ><Terminator>
X	---	X	---	<Header><Code 93 data><DPS><EAN 8 data><Terminator>

X	---	---	X	<Header><Code 93 data><DPS><UPC-A data><Terminator>
---	X	X	---	<Header><Interleaved 2/5 data><DPS><EAN 8 data><Terminator>
---	X	---	X	<Header><Interleaved 2/5 data><DPS><UPC-A data><Terminator>
X	X	X	X	<Header><First decoded code/Multiple Read Message string><DPS>< First decoded code/Multiple Read Message string ><Terminator>

**No Read Message**

Select Disable No Read Message, Global No Read Message, or Local No Read(s) Message from the drop-down list. The No Read condition occurs whenever a code cannot be read or decoded.

**Disable No Read Message:** The No Read Message is not transmitted.

**Global No Read Message:** The No Read String will be sent if the scanner is unable to decode one or more barcodes in the reading phase.

**Local No Read(s) Message:** This option is useful when one or more codes are not read in the reading phase or when more codes than the expected number set by the configuration parameters are read.

If working in Logical Combination mode, this option reveals Group No Read Messages fields, which allows entering group no read strings.

**Group No Read Messages**

Group 1 No Read String  

Group 2 No Read String  

**Use 'Global No Read String' when No Codes Read**

Select the check box to allow the Global No Read String to be used if no codes at all are read. This option is not available when Global No Read Message is selected from the No Read Message drop-down list.

**Global No Read String (max. 128 chars)**

Click  to activate the Text Entry Tool and create a string to be displayed when Global No Read Message is selected from the No Read Message drop-down list. Click Submit to save your text to the origin window text field, or click Cancel to return to origin window without transferring text.

**Multiple Read Message**

Select Disable or Enable from the drop-down list. This string will be sent if, during the reading phase, the scanner reads more than the number of the expected barcodes set by the configuration parameters.

If Disable No Read Message or Global No Read Message is selected from the No Read Message drop-down list, this string will be sent if, during the reading phase, the scanner reads more than the number of the expected barcodes set by the configuration parameters.

If Local No Read(s) Message is selected from the No Read Message drop-down list, the Group Multiple Read Message fields appears, allowing the user to enter strings for each Group

**Group Multiple Read Messages**

Group 1 Multiple Read String  

Group 2 Multiple Read String  

**Multiple Read String (max. 128 chars)**

Click  to activate the Text Entry Tool and create a string to be displayed in case of Multiple Read Message. Click Submit to save your text to the origin window text field, or click Cancel to return to origin window without transferring text.

This parameter is only available when Multiple Read Message is enabled and the No Read Message selection is different from Local No Read(s) String. It is possible to select either the ASCII or HEX value. If disabled, the scanner transmits the first code read.

**Send All Multiple Read Labels**

Select Enable or Disable. For Advanced Data Formats only, by enabling this parameter all multiple read labels will be included in the output message. They can be separated by the Multiple Read Separator.

**Multiple Read Label Separator String (max. 128 chars):**

The Multiple Read Label Separators (up to 128 bytes) are used to separate multiple read barcodes in the reading phase.

This is meaningful when the Code Combination parameter is set to Multi Label or Logical Combination and the Send All Multiple Read Labels parameter has been enabled.

If selected, they occur within the Code Field and are transmitted after each decoded multiple read barcode.

**Multi Filters**

Select the check box to display the Multi-Filter Settings options.

**Multi-Filter Settings**

Multi-Filter Settings	
Contained Filter	<input type="checkbox"/>
Voting Filter	<input type="checkbox"/>
Filter Out Low Height Codes	<input type="checkbox"/>
Strip Filter	<input type="checkbox"/>
Priority Filter Enable	<input type="checkbox"/>

**Contained Filter**

Select the check box to reveal the [Max Number of Different Characters](#) field.

When checked, this filter attempts to eliminate false multiple reads by determining if a short code read is "contained in" (is a sub-string of), another longer code read. This condition implicates that the short code is probably a misread of the same longer code and therefore should be ignored, (should not be considered as a multiple read of a different code).

This filter is based upon the following rules:

a multiple read condition occurs

all decoded codes of the same type are compared with each other

Rule 1: the shorter code is considered contained in the longer code if the character string is found in the same order; the longer code may have a single block of characters in any position (before, after or in between the compared strings)

Example: The code 123456 is considered contained in the following codes: 00123456, 12345600, 12378456.

The code 123456 is not considered contained in the following codes: 12346507 (string out of order), 12345700 (string not complete), 120378456 or 0012345600 (multiple blocks in the string).

Rule 2: the shorter code is not filtered by rule 1. In the longer code, all possible sub-strings of the same length as the shorter code string are compared with the shorter code string. The shorter code is considered contained in the longer code if the number of different characters between the compared codes is less than or equal to the Max Number of Different Characters. The shorter code will be filtered by rule 2.

If Max Number of Different Characters = 1:

The code 123456 is considered contained in the following codes: 12305600, 00123056, 8812305688 because there is only one different character in the compared string.

The code 123456 is not considered contained in 123066789 because there are two different characters in the compared string.

**WARNING**



**If the Contained Filter parameter is used when Message Tx Selection is set to On Decoding, the filter conditions may be satisfied before the reading phase ends resulting in possible successive multiple read errors.**

### Max Number of Different Characters

Enter a value from 0 to 5 in the field provided to define the maximum number of different characters allowed to still consider a code as being included in another one and therefore to be filtered.

If the number of different characters between the compared codes exceeds the value of this parameter, the codes are considered as different and will not be filtered (a multiple read of a different code occurs).

If the number of different characters between the compared codes is less than or equal to the value of this parameter, the short code is considered as a sub-string of the longer code and will be filtered (no multiple read occurs).

If Max Number of Different Characters = 2:

The code 123456 read once, is considered the same as the following codes read multiple times: 133056, 123546, 123457 because there are two or less different characters by position in the compared codes.

The code 123456 read once, is not considered the same as the following codes read multiple times: 153246, 103057, 654321 because there are at least three different characters by position in the compared codes.

### Voting Filter

Select the check box to reveal the [Max Number of Different Characters](#) field.

When checked, this filter attempts to eliminate false multiple reads by comparing the number of different characters by position between two codes of the same type and length. This condition implicates that reading a code of the same type and length having very few different characters is probably a misread of the code itself and therefore the code read the least number of times should be ignored, (should not be considered as a multiple read of a different code).

This filter is based upon the following rules:

- a multiple read condition occurs;
  - the two codes are of the same type;
  - the two codes have the same length;
  - the number of different characters by position is equal to or less than the number defined by the [Max Number of Different Characters](#) parameter;
- [Message Tx Selection](#) must be set to After Reading Phase Off.

### Max Number of Different Characters

Enter a value from 0 to 5 in the field provided to define the maximum number of different characters allowed to still consider a code as being included in another one and therefore to be filtered.

If the number of different characters between the compared codes exceeds the value of this parameter, the codes are considered as different and will not be filtered (a multiple read of a different code occurs).

If the number of different characters between the compared codes is less than or equal to the value of this parameter, the short code is considered as a sub-string of the longer code and will be filtered (no multiple read occurs).

#### **Examples:**

If Max Number of Different Characters = 2:

The code 123456 read once, is considered the same as the following codes read multiple times: 133056, 123546, 123457 because there are two or less different characters by position in the compared codes.

The code 123456 read once, is not considered the same as the following codes read multiple times: 153246, 103057, 654321 because there are at least three different characters by position in the compared codes.

**Filter Out Low Height Codes**

Select the check box to reveal the Minimum Readings Difference Between Scanners field.

Background: This option was developed for the airports systems where there are often tall bar height codes and low bar height codes with the same content attached to baggage. Travelers will often remove the large, tall bar height code, while leaving the smaller, low bar height codes attached to the bag. The next time they travel they may have multiple low bar height codes on their baggage plus the new tall bar height and low bar height codes for the new trip.

This option instructs the system to ignore low bar height codes, which are likely read only once or twice, in favor of tall bar height codes, which will likely be read multiple times.

This is used in tunnel applications where multiple barcodes are read and there is a need to filter out one of the barcodes. If less than x number of scanners read the barcode, then it will be considered a NOREAD for that code.

**Minimum Readings Difference Between Scanners**

Enter the minimum number of scanners that must read a barcode for it to be considered a valid read.

**Filter Out Single Readings**

With the check box selected, if only 1 scanner reads a code it will be considered a NOREAD.

**Strip Filter**

Select the check box to display the Strip Filter Settings options. This is a second level filter that when enabled allows eliminating characters not managed by the host.

**Strip Filter Settings**
**Strip All Non Printable Chars**

Select the check box to remove all non- printable ASCII characters from the code (000-020 and 127).

**Char(s) to be Stripped**

Click  to activate the Text Entry Tool and enter specific characters to be stripped from the code. Click Submit to save your text to the origin window text field, or click Cancel to return to origin window without transferring text.

**Strip Filter Collapse**

Select the check box to remove the stripped characters from the code and, therefore, reduce the code length (collapsed). It can even be null.

**Replacement Char**

If Strip Filter Collapse is not selected, click  to activate the Text Entry Tool and enter the substitution character to replace all the stripped ones. Click Submit to save your text to the origin window text field, or click Cancel to return to origin window without transferring text

**Priority Filter Enable**

Select the check box to display the Priority Filter options. This function allows the user to prioritize barcodes.

**Example:**

If there is a message with a field that should contain one of multiple code types (for example, Code128, Code39 and I2of5). In this field, the user wants:

If Code 128 is read, it goes in the field (any code39 and I2of5 are ignored)

If Code 128 is not read - if Code39 is read, it goes in the field (and I2of5 is ignored)

If Code 128 and Code30 are not read – if i2of5 is read, it goes in the field.

### **Priority Filter Group List**

Enter the Group List in the field provided. This field defines the specific Logical Combination groups to which the Priority Filter will apply. The groups are numbered according to the order in which they are listed (from left to right) in the Logical Combination Rule parameter.

Format: Group Number(s) separated by the comma character

#### **Example:**

1,3 means the Priority Filter is applied to Logical Groups 1 and 3. Logical Group 2 will not have the Priority Filter applied, however it will follow the normal rules of code analysis, and if selected, the Strip Filter parameters will apply.

### **Priority Filter Type**

Select Normal or Advanced from the drop-down list.

#### **Description:**

Normal: Uses the Logical Combination Rule string to define the priority

Advanced: Uses the Priority Filter Advanced String to define the priority. Advanced type allows the priority filter to essentially take "priority" over the Logical Combination Rule string.

#### **NORMAL**

When the Priority Filter Type is set to Normal, the operators used in the Logical Combination Rule string have the following meaning:

& = AND operator which separates a group from the previous/following one;

^ = The priority is given to the code label indicated to the left of the operator. If this code is read, the group is in Good Read independent from any other code in the same group.

#### **Example:**

Logical Combination Rule = 1^2&5^3^4&6^7 (3 groups)

Results Without Priority Filter:

Group 1 – read either code 1 or 2 = Good Read; read both code 1 and 2 = Multiple Read

Group 2 – read either code 5 or 3 or 4 = Good Read; read any combination = Multiple Read

Group 3 – read either code 6 or 7 = Good Read; read both code 6 and 7 = Multiple Read

Results With Priority Filter:

Filter Enabled on Groups = 1,2

Group 1 – read code 1 = Good Read independent from reading code 2

Group 2 – read code 5 = Good Read independent from reading code 3 or 4; read code 3 = Good Read independent from reading code 4

Group 3 – read either code 6 or 7 = Good Read; read both code 6 and 7 = Multiple Read

#### **ADVANCED**

When the Priority Filter Type is set to Advanced, the Priority Filter Advanced String applies to the Logical Combination Groups. This string must correspond to the order of the groups defined in the Logical Combination Rule string.

The following operators can be used:

& = Code group separator. This operator separates a group from the previous/following one;

^ = The priority is given to the code label indicated to the left of this operator. If this code is read, the group is in Good Read independent from any other code in the same group.

| = Equal priority operator (vertical line). Codes separated by this operator have the same priority and if both codes are read a Multiple Read will result.

The only difference from the implicit pattern string of the Normal (default) case when the Logical Combination Rule string is used, is the Equal Priority operator.

#### **Example:**

Logical Combination Rule = 1^2&5^3^4&8^6^7 (3 groups)



**Results Without Priority Filter:**

Group 1 – read either code 1 or 2 = Good Read; read both code 1 and 2 = Multiple Read

Group 2 – read either code 5 or 3 or 4 = Good Read; read any combination = Multiple Read

Group 3 – read either code 8 or 6 or 7 = Good Read; read any combination = Multiple Read

**Results With Priority Filter:**

Filter Enabled on Groups = 1,3

Filter Type =Custom

Custom Filter Pattern String = 1^2&8^6|7 (2 groups)

Group 1 – read code 1 = Good Read independent from reading code 2

Group 2 – read either code 5 or 3 or 4 = Good Read; read any combination = Multiple Read

Group 3 – read code 8 = Good Read independent from reading code 6 or 7; no read on code 8 and read either code 6 or 7 = Good Read; no read on code 8 and read both code 6 and 7 = Multiple Read

**Priority Filter Advanced String**

Enter the character string (see above).

2. When you have finished making changes, click **Update All** to save all pending changes, click **Reset All** to revert to all previously saved values, and click **Reset Page** to revert to previous saved values on the current page.

## Barcode Configuration | Code Collection

When Code Collection has been selected from the Code Combination drop-down list, the Barcode Configuration window reveals related input fields.

The screenshot shows the 'Barcode Configuration' window. At the top, 'Code Combination' is set to 'Code Collection'. Below it, 'No Read Message' is set to 'Disable No Read Mess:'. There is a checkbox for 'Use 'Global No Read String' when No Codes Read'. A sub-section titled 'Code Collection Settings' contains a checkbox for 'Associate All 'Same Codes' Read By Any Scanner', two input fields for 'Code Different When Scan Gap Is Greater Than' and 'Code Different When Code Position Gap Is Greater Than' (both set to 0), and a checkbox for 'Multi Filters'. At the bottom are buttons for 'Update All', 'Reset All', and 'Reset Page'.

1. Enter the appropriate information in the form as described below:

### Code Combination – Code Collection has been selected. No Read Message

Select Disable No Read Message, Global No Read Message, or Local No Read(s) Message from the drop-down list. The No Read condition occurs whenever a code cannot be read or decoded.

**Disable No Read Message:** The No Read Message is not transmitted.

**Global No Read Message:** The No Read String will be sent if the scanner is unable to decode one or more barcodes in the reading phase.

**Local No Read(s) Message:** This option is useful when one or more codes are not read in the reading phase or when more codes than the expected number set by the configuration parameters are read.

### Use 'Global No Read String' when No Codes Read

Select the check box to allow the Global No Read String to be used if no codes at all are read. This option is not available when Global No Read Message is selected from the No Read Message drop-down list.

### Global No Read String (max. 128 chars)

Click  to activate the Text Entry Tool and create a string to be displayed when Global No Read Message is selected from the No Read Message drop-down list. Click Submit to save your text to the origin window text field, or click Cancel to return to origin window without transferring text.

### Code Collection Settings

The screenshot shows the 'Code Collection Settings' section. It includes a checkbox for 'Associate All 'Same Codes' Read By Any Scanner', two input fields for 'Code Different When Scan Gap Is Greater Than' and 'Code Different When Code Position Gap Is Greater Than' (both set to 0), and a checkbox for 'Multi Filters'.

### Associate All Same Codes When Read By Any Scanner

Select the check box to enable this function, which eliminates duplicate codes from a single scanner.



**The next two options are only available when the Operating Mode is set to On Line and the Associate All "Same Codes" Read By Any Scanner is unchecked.**

### Code Different When Scan Cap is Greater Than

Enter a minimum distance in mm which is required for the system to consider the next code a different one.

The parameter set to 0 means the filter is disabled: when there is no scan gap all the consecutive codes read will be considered as only one code. This defines the gap between two packages.

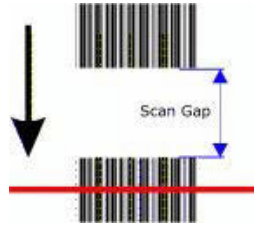

### Code Different when Code Position Gap is Greater Than

Enter a minimum distance in mm which is required for the system to consider the next code a different one. This defines the gap between two bar codes.

This parameter is available only when the Code Combination parameter is set to Code Collection and the scanner role is Master. If enabled, it allows transmitting all codes belonging to the same programmed Slot (same symbology and content) but read by different scanners (including the Master) in a single instance.

Scanner Role:

**Master SYNCHRONIZED:** The scanner is connected as a Master in a master/slave synchronized configuration.

**Slave SYNCHRONIZED:** The scanner is connected as a Slave in a master/slave synchronized configuration. (See note below.)

**Other:** This selection is for a stand-alone scanner.

The parameter set to 0 means the filter is disabled: when there is no code position gap all the consecutive codes read will be considered as only one code.

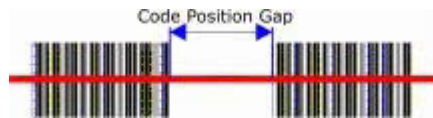

### Multi Filters

Select the check box to display the Multi-Filter Settings options.

#### Multi-Filter Settings

Multi-Filter Settings	
Contained Filter	<input type="checkbox"/>
Voting Filter	<input type="checkbox"/>
Filter Out Low Height Codes	<input type="checkbox"/>
Strip Filter	<input type="checkbox"/>
Priority Filter Enable	<input type="checkbox"/>

### Contained Filter

Select the check box to reveal the [Max Number of Different Characters](#) field.

When checked, this filter attempts to eliminate false multiple reads by determining if a short code read is "contained in" (is a sub-string of), another longer code read. This condition implicates that the short code is probably a misread of the same longer code and therefore should be ignored, (should not be considered as a multiple read of a different code).

This filter is based upon the following rules:

a multiple read condition occurs

all decoded codes of the same type are compared with each other

Rule 1: the shorter code is considered contained in the longer code if the character string is found in the same order; the longer code may have a single block of characters in any position (before, after or in between the compared strings)

Example: The code 123456 is considered contained in the following codes: 00123456, 12345600, 12378456.

The code 123456 is not considered contained in the following codes: 12346507 (string out of order), 12345700 (string not complete), 120378456 or 0012345600 (multiple blocks in the string).

Rule 2: the shorter code is not filtered by rule 1. In the longer code, all possible sub-strings of the same length as the shorter code string are compared with the shorter code string. The shorter code is considered contained in the longer code if the number of different characters between the compared codes is less than or equal to the Max Number of Different Characters. The shorter code will be filtered by rule 2.

Example:

If Max Number of Different Characters = 1:

The code 123456 is considered contained in the following codes: 12305600, 00123056, 8812305688 because there is only one different character in the compared string.

The code 123456 is not considered contained in 123066789 because there are two different characters in the compared string.



**If the Contained Filter parameter is used when [Message Tx Selection](#) (see section ) is set to On Decoding, the filter conditions may be satisfied before the reading phase ends resulting in possible successive multiple read errors.**

#### Max Number of Different Characters

Enter a value from 0 to 5 in the field provided to define the maximum number of different characters allowed to still consider a code as being included in another one and therefore to be filtered.

If the number of different characters between the compared codes exceeds the value of this parameter, the codes are considered as different and will not be filtered (a multiple read of a different code occurs).

If the number of different characters between the compared codes is less than or equal to the value of this parameter, the short code is considered as a sub-string of the longer code and will be filtered (no multiple read occurs).

If Max Number of Different Characters = 2:

The code 123456 read once, is considered the same as the following codes read multiple times: 133056, 123546, 123457 because there are two or less different characters by position in the compared codes.

The code 123456 read once, is not considered the same as the following codes read multiple times: 153246, 103057, 654321 because there are at least three different characters by position in the compared codes.

#### Voting Filter

Select the check box to reveal the [Max Number of Different Characters](#) <XREF> field.

When checked, this filter attempts to eliminate false multiple reads by comparing the number of different characters by position between two codes of the same type and length. This condition implicates that reading a code of the same type and length having very few different characters is probably a misread of the code itself and therefore the code read the least number of times should be ignored, (should not be considered as a multiple read of a different code).

This filter is based upon the following rules:

a multiple read condition occurs;

the two codes are of the same type;

the two codes have the same length;

the number of different characters by position is equal to or less than the

number defined by the [Max Number of Different Characters](#) parameter;

[Message Tx Selection](#) (see section ) must be set to After Reading Phase Off.

**Max Number of Different Characters**

Enter a value from 0 to 5 in the field provided to define the maximum number of different characters allowed to still consider a code as being included in another one and therefore to be filtered.

If the number of different characters between the compared codes exceeds the value of this parameter, the codes are considered as different and will not be filtered (a multiple read of a different code occurs).

If the number of different characters between the compared codes is less than or equal to the value of this parameter, the short code is considered as a sub-string of the longer code and will be filtered (no multiple read occurs).

If Max Number of Different Characters = 2:

The code 123456 read once, is considered the same as the following codes read multiple times: 133056, 123546, 123457 because there are two or less different characters by position in the compared codes.

The code 123456 read once, is not considered the same as the following codes read multiple times: 153246, 103057, 654321 because there are at least three different characters by position in the compared codes.

**Filter Out Low Height Codes**

Select the check box to reveal the Minimum Readings Difference Between Scanners field.

Background: This option was developed for the airports systems where there are often tall bar height codes and low bar height codes with the same content attached to baggage. Travelers will often remove the large, tall bar height code, while leaving the smaller, low bar height codes attached to the bag. The next time they travel they may have multiple low bar height codes on their baggage plus the new tall bar height and low bar height codes for the new trip.

This option instructs the system to ignore low bar height codes, which are likely read only once or twice, in favor of tall bar height codes, which will likely be read multiple times.

This is used in tunnel applications where multiple barcodes are read and there is a need to filter out one of the barcodes. If less than x number of scanners read the barcode, then it will be considered a NOREAD for that code.

**Minimum Readings Difference Between Scanners**

Enter the minimum number of scanners that must read a barcode for it to be considered a valid read.

**Filter Out Single Readings**

With the check box selected, if only 1 scanner reads a code it will be considered a NOREAD.

**Strip Filter**

Select the check box to display the Strip Filter Settings options. This is a second level filter that when enabled allows eliminating characters not managed by the host.

**Strip Filter Settings**



**Strip All Non Printable Chars**

Select the check box to remove all non- printable ASCII characters from the code (000-020 and 127).

**Char(s) to be Stripped**

Click  to activate the Text Entry Tool and enter specific characters to be stripped from the code. Click Submit to save your text to the origin window text field, or click Cancel to return to origin window without transferring text.

### Strip Filter Collapse

Select the check box to remove the stripped characters from the code and, therefore, reduce the code length (collapsed). It can even be null.

### Replacement Char

If Strip Filter Collapse is not selected, click  to activate the Text Entry Tool and enter the substitution character to replace all the stripped ones. Click Submit to save your text to the origin window text field, or click Cancel to return to origin window without transferring text.

2. When you have finished making changes, click **Update All** to save all pending changes, click **Reset All** to revert to all previously saved values, and click **Reset Page** to revert to previous saved values on the current page.

## Serial Ports

Use the Serial Ports menu tree selections during initial setup to configure any serial ports used by your barcode scanning system. If necessary, you can later make modifications to the global system settings using the same menu selections, including:

[“Main Serial Port” on page 103](#)

[“Aux Serial Port” on page 106](#)



## Main Serial Port

Use the **Main Port** window to configure communication between the scanner and a Host, in a multi-sided layout, between the Master (scanner/controller) and a Host.

To edit the Main Serial Port settings:

1. In the menu under **Modify Settings**, navigate to **Global Settings | Serial Ports | Main Serial Port**. The Main Port window opens.

2. Enter the appropriate information in the form as described below:

### Enable Data Transmission

Select the check box to enable Data Tx. If selected, the Main Serial Port channel is used by the scanner to transmit data and/or messages.

### Heartbeat

Select Disable, Enable Unconditioned, or Enable Conditioned from the drop-down list. This parameter is available when the Data TX parameter is checked. It enables/disables the transmission of the Heartbeat message signaling that the device is still active.

**Disable:** The Heartbeat message is not transmitted

**Enable Unconditioned:** The Heartbeat message is always transmitted, even if communication is still active

**Enable Conditioned:** The Heartbeat message is transmitted only when there is no communication

### **Heartbeat Settings**

### Heartbeat Timeout

Enter a time value in seconds to define the amount of time between two message transmissions. If the input timeout expires and no transmission has occurred, the Heartbeat message will be transmitted.

### Heartbeat Message (max. 32 chars)

Click  to activate the Text Entry Tool and create heartbeat header text to signal the beginning of the heartbeat message. Characters from NUL (00H) to ~ (7EH) can

be used. Click Submit to save your text to the origin window text field, or click Cancel to return to origin window without transferring text.

The Heartbeat Message (header) string must be different from the Heartbeat Terminator string.

**Heartbeat Terminator (max. 32 chars)**

Click  to activate the Text Entry Tool and create Heartbeat Terminator text to signal the end of the heartbeat message. Characters from NUL (00H) to ~ (7EH) can be used. Click Submit to save your text to the origin window text field, or click Cancel to return to origin window without transferring text.

The Heartbeat Terminator string must be different from the Heartbeat Message (header) string.

**Send Failure Bitmap**

Select the check box to include a Failure Bitmap in the heartbeat message. The Failure Bitmap is the information pertaining to any error that may be encountered by the scanner. This message may be transmitted in the following format.

**Failure Bitmap Format**

Select the format of the Failure Bitmap from the drop-down.

- Decimal (ASCII)
- Hexidecimal (ASCII)
- Bitmap (ASCII)
- Numeric (Binary)

**Failure Bitmap Size**

Select the size fo the Failure Bitmap from the drop-down. Options are, Variable, or 1-32.

**Line Settings**

Line Settings	
Main Port Communication Mode	Standard ▼
Main Port Electrical Interface	RS232 ▼
Handshake	None ▼
Baud Rate	115200 ▼
Parity	None ▼
Data Bits	8 ▼
Stop Bits	1 ▼

**Main Port Communication Mode**

Select Standard or Siemens 3964 from the drop-down list.

Siemens 3964: The procedure 3964(R) adds control characters (security layer) to the information data when transferring it. These control characters enable the communication partner to check whether the data has been received in full and without any errors. The procedures 3964(R) evaluate the following control characters:

Control characters	Meaning
STX	Start of Text
DLE	Data Link Escape
ETX	End of Text
BCC	Block Check Character (only 3964R/RK512)
NAK	Negative Acknowledge

**Main Port Electrical Interface**

Select RS232 or RS422 full duplex from the drop-down list. The Main serial interface is compatible with these available electrical standards.

**Handshake**

Select None, Hardware (RTS/CTS), or Software (Xon/Xoff) from the drop-down list. Handshake is a communication control used to protect against data loss, it can be achieved via hardware (RTS\CTS protocol) or software (Xon\Xoff protocol).

**Baud Rate**

Select a value from 1200 to 115200 from the drop-down list. Baud Rate is the transmission speed in a communication line.

**Parity**

Select None, Odd, or Even from the drop-down list. Parity is a parameter indicating the presence of a control bit in the communication protocol frame.

**Checksum**

Click the checkbox to enable a check digit representing the sum of the correct digits which can detect errors in the data. Only available for Siemens 3964.

**Priority**

Select Low or High from the drop-down list. Only available for Siemens 3964.

**Data Bits**

Select 7 or 8 from the drop-down list. Data Bits is a parameter indicating the number of bits composing the data packet of the communication protocol frame.

**Stop Bits**

Select 1 or 2 from the drop-down list. Stop Bits is a parameter indicating the number of stop bits in the data packet of the communication protocol frame.

3. When you have finished making changes, click **Update All** to save all pending changes, click **Reset All** to revert to all previously saved values, and click **Reset Page** to revert to previous saved values on the current page.

## Aux Serial Port

Use the **Aux Serial Port** window to configure communication through the Auxiliary Serial Port. For this communication mode, RS232 interface is automatically selected.

To edit the **Aux Serial Port** settings:

1. In the menu under **Modify Settings**, navigate to **Global Settings | Serial Ports | Aux Serial Port**. The Aux Serial Port window opens.

2. Enter the appropriate information in the form as described below:  
**Search for CBX BM100 at Device Startup**

Select the check box to automatically search for a BM100 storage module when the scanner is powered on.

Only available if BM100 included.

### **Enable Data Transmission**

Select the check box to enabled Data Tx. If selected, the Aux Serial Port channel is used by the scanner to transmit data and/or messages.

### **Heartbeat**

Select Disable, Enable Unconditioned, or Enable Conditioned from the drop-down list. This parameter is available when the Data TX parameter is checked. It enables/disables the transmission of the Heartbeat message signaling that the device is still active.

**Disable:** The Heartbeat message is not transmitted

**Enable Unconditioned:** The Heartbeat message is always transmitted, even if communication is still active

**Enable Conditioned:** The Heartbeat message is transmitted only when there is no communication

### **Heartbeat Settings**

### **Heartbeat Timeout**

Enter a time value in seconds to define the amount of time between two message transmissions. If the input timeout expires and no transmission has occurred, the Heartbeat message will be transmitted.

### **Heartbeat Message (max. 32 chars)**

Click to activate the Text Entry Tool and create heartbeat header text to signal the beginning of the heartbeat message. Characters from NUL (00H) to ~ (7EH) can be used. Click Submit to save your text to the origin window text field, or click Cancel to return to origin window without transferring text.

The Heartbeat Message (header) string must be different from the Heartbeat Terminator string.

### Heartbeat Terminator (max. 32 chars)

Click  to activate the Text Entry Tool and create Heartbeat Terminator text to signal the end of the heartbeat message. Characters from NUL (00H) to ~ (7EH) can be used. Click Submit to save your text to the origin window text field, or click Cancel to return to origin window without transferring text.

The Heartbeat Terminator string must be different from the Heartbeat Message (header) string

### Send Failure Bitmap

Select the check box to include a Failure Bitmap in the heartbeat message. The Failure Bitmap is the information pertaining to any error that may be encountered by the scanner. This message may be transmitted in the following format.

### Failure Bitmap Format

Select the format of the Failure Bitmap from the drop-down.

Decimal (ASCII)  
Hexidecimal (ASCII)  
Bitmap (ASCII)  
Numeric (Binary)

### Failure Bitmap Size

Select the size for the Failure Bitmap from the drop-down. Options are, Variable, or 1-32.

### Line Settings

Line Settings	
Baud Rate	115200 ▼
Parity	None ▼
Data Bits	8 ▼
Stop Bits	1 ▼

### Baud Rate

Select a value from 1200 to 115200 from the drop-down list. Baud Rate is the transmission speed in a communication line.

### Parity

Select None, Odd, or Even from the drop-down list. Parity is a parameter indicating the presence of a control bit in the communication protocol frame.

### Data Bits

Select 7 or 8 from the drop-down list. Data Bits is a parameter indicating the number of bits composing the data packet of the communication protocol frame.

### Stop Bits

Select 1 or 2 from the drop-down list. Stop Bits is a parameter indicating the number of stop bits in the data packet of the communication protocol frame.

- When you have finished making changes, click **Update All** to save all pending changes, click **Reset All** to revert to all previously saved values, and click **Reset Page** to revert to previous saved values on the current page.

## Ethernet

Use the **Ethernet** menu tree selections during initial setup to configure the Ethernet settings for your barcode scanning system.

Ethernet is the most popular physical layer LAN technology in use today. It is the IEEE 802.3 series standard, based on the CSMA/CD access method that provides two or more stations to share a common cabling system. This access method, Carrier Sense Multiple Access with Collision Detection, is the basis for Ethernet systems providing a wide range of speed.

The design goals for Ethernet are to create a simply defined topology that makes efficient use of shared resources that are easy to reconfigure and maintain and provides compatibility across many manufacturer and systems.

Ethernet supports many different network protocols; Datalogic scanners support IP plus TCP or UDP over Ethernet and 802.3 frame format as Ethernet protocol low level.

If necessary, you can later make modifications to the global system settings using the same menu selections, including:

Ethernet

[“Ethernet | Line Settings” on page 109](#)

[“Ethernet | User Sockets” on page 111](#)

[“Ethernet | Ethernet\\_IP” on page 115](#)

[“Ethernet | WebSentinel” on page 119](#)

## Ethernet | Line Settings

Use the **Line Settings** window to define and report the fundamental information about the system.

**To edit the Line Settings:**

1. In the menu under Modify Settings, navigate to Global Settings | Ethernet | Line Settings. The Line Settings window opens.

2. Enter the appropriate information in the form as described below:

### **Host Network (HOST)**

#### Enable DHCP

Select the check box to cause the IP address parameters to become inactive. They are then used to display the addresses assigned by a DHCP server.

#### Host IP Address

Enter the Internet Protocol (IP) network address for ETH2 (Setup) in the field provided. Consult your network administrator to obtain a new address. [Host IP](#)

#### Netmask

Enter the device subnet mask address in the field provided. Consult your network administrator to obtain a new address.

#### Host IP Gateway

Enter the device gateway address in the field provided. Consult your network administrator to obtain a new address.

#### Host IP DNS1

Enter the address of the Primary Domain Name System (DNS) in the field provided.



### Host IP DNS2

Enter the address of the Secondary Domain Name System (DNS) in the field provided.

### Setup Network (CFG) Setup IP Address

Enter the IP address for ETH2 (CFG) in the field provided. Consult your network administrator to obtain a new address.

### Setup Netmask

Enter the subnet mask address for ETH2 (Setup) in the field provided. Consult your network administrator to obtain a new address.

### Disable Config Net on Inactive SC5000

Click the check-box to disable the config port on the inactive SC5000.

3. When you have finished making changes, click **Update All** to save all pending changes, click **Reset All** to revert to all previously saved values, and click **Reset Page** to revert to previous saved values on the current page.

## Ethernet | User Sockets

Use the **User Sockets** (User Socket Settings) window to setup, edit, and configure numbered user sockets for your barcode scanning system. User sockets are another interface available for Ethernet communication.

To edit the **User Socket** settings:

1. In the menu under **Modify Settings**, navigate to **Global Settings | Ethernet | User Sockets**. The User Sockets window opens.

The screenshot shows the 'User Socket Settings' window. At the top, there is a table with the following data:

Idx	Type	Protocol	Port
<input checked="" type="radio"/> 1	Client	TCP	51236
<input type="radio"/> 2	Server	TCP	51237
<input type="radio"/> 3			
<input type="radio"/> 4	Server	TCP	51232
<input type="radio"/> 5			

Below the table is the 'User Socket 1' configuration section. It includes:

- Enable User Socket:**
- Enable Data Transmission:**
- Heartbeat:** **Enable Unconditioned** (dropdown)
- Heartbeat Settings:**
  - Heartbeat Timeout:** 60 sec
  - Heartbeat Message:** <STX>
  - Heartbeat Terminator:** <ETX>
  - Send Failure Bitmap:**
  - Failure Bitmap Format:** Bitmap (ASCII) (dropdown)
  - Failure Bitmap Size:** 32 (dropdown)
- Socket Configuration:**
  - Type:** Client (dropdown)
  - Server Address:** 0.0.0.0
  - Protocol:** TCP (dropdown)
  - Port:** 51236

At the bottom of the window are three buttons: **Update All**, **Reset All**, and **Reset Page**.

2. Enter the appropriate information in the form as described below:

### User Socket List

Select an option button in the list at the top of this window to create a new user socket, or to edit an existing one.

### Idx

Select the Idx for the row/user socket you wish to enter or edit.

If a row is disabled, a user socket can be selected and configured for that row.

If a user socket is displayed in the selected row, its configuration can be edited.

### Type

The type of socket specified.

### Protocol

The type of protocol specified.

**Port**

The port number specified.

**User Socket n  
Enable User Socket**

Select the check box to enable User Sockets and reveal the related configuration options.

**Enable Data Transmission**

Select the check box to enable User Sockets and reveal the related configuration options. When enabled, Ethernet User Socket is selected as the channel to be used by the scanner for transmitting data and/or messages.

**Heartbeat**

Select Disable, Enable Unconditioned, or Enable Conditioned from the drop-down list. This parameter is available when the Data TX parameter is checked. It enables/disables the transmission of the Heartbeat message signaling that the device is still active.

**Disable:** The Heartbeat message is not transmitted

**Enable Unconditioned:** The Heartbeat message is always transmitted, even if communication is still active

**Enable Conditioned:** The Heartbeat message is transmitted only when there is no communication

**Heartbeat Settings**

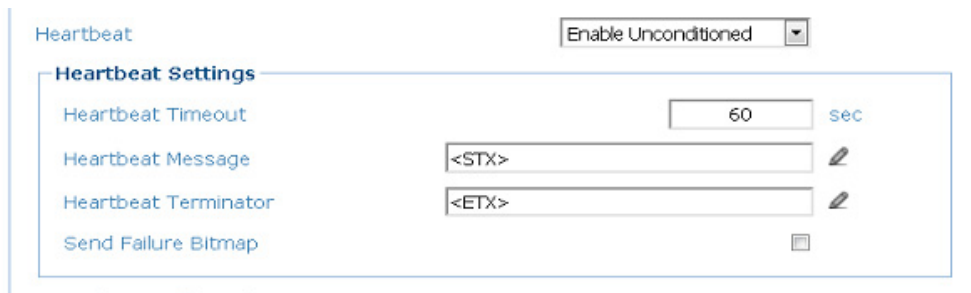

**Heartbeat Timeout**

Enter a time value in seconds to define the amount of time between two message transmissions. If the input timeout expires and no transmission has occurred, the Heartbeat message will be transmitted.

**Heartbeat Message (max. 32 chars)**

Click to activate the Text Entry Tool and create heartbeat header text to signal the beginning of the heartbeat message. Characters from NUL (00H) to ~ (7EH) can be used. Click Submit to save your text to the origin window text field, or click Cancel to return to origin window without transferring text.

The Heartbeat Message (header) string must be different from the Heartbeat Terminator string.

**Heartbeat Terminator (max. 32 chars)**

Click to activate the Text Entry Tool and create Heartbeat Terminator text to signal the end of the heartbeat message. Characters from NUL (00H) to ~ (7EH) can be used. Click Submit to save your text to the origin window text field, or click Cancel to return to origin window without transferring text.

The Heartbeat Terminator string must be different from the Heartbeat Message (header) string

**Send Failure Bitmap**

Select the check box to include a Failure Bitmap in the heartbeat message.

**Failure Bitmap Format**

Select the Format of the Failure Bitmap from the drop-down. Options are; Decimal (ASCII), Hexidecimal (ASCII), Bitmap (ASCII) and Numeric (Binary)

### Failure Bitmap Size

Select the size of the Failure Bitmap from the drop-down; options are Variable, or 1-32.

### Socket Configuration Type

Select Server or Client from the drop-down list to define the type of the socket:

**When the Protocol selected is TCP (see below):**

**Server:** The station waits for connections and can communicate with a maximum of 3 clients simultaneously.

Socket Configuration	
Type	Server
Protocol	TCP
Port	51236

**Client:** The station tries a connection towards the server.

Socket Configuration	
Type	Client
Server Address	0.0.0.0
Protocol	TCP
Port	51236

**When the Protocol selected is UDP (see below):**

**Server:** Special Datalogic mode in which the station waits to receive a message (content of message does not matter), then responds with UDP host messages to that client. You must enter a port number, and if using a fixed UDP destination port, you must enter the number for that port as well.

Socket Configuration	
Type	Server
Protocol	UDP
Port	51236
Fixed UDP Destination Port	<input checked="" type="checkbox"/>
UDP Destination Port	51242

**Client:** Choose this option for standard UDP protocol. You must define the Server Address that will be receiving the UDP messages and port. If using a fixed UDP source port, you must enter the UDP source port number.

Socket Configuration	
Type	Client
Server Address	0.0.0.0
Protocol	UDP
Port	51236
Fixed UDP Source Port	<input checked="" type="checkbox"/>
UDP Source Port	51248

### Server Address

Enter the IP address of the server to which the client tries to connect. This parameter is available only when the socket is configured as a Client.

### Protocol

Select TCP (Transmission Control Protocol) or UDP (User Datagram Protocol) from the drop-down list to define the protocol to be used for the Ethernet communication.



**When using the UDP protocol:**

**The User Socket Client Port is bound to the Server Port.**

**The maximum size for maintaining a whole datagram is 1436 bytes, messages exceeding this value will be fragmented.**

### Port

Enter the Port Number of the socket.

### Fixed UDP Destination Port

When using UDP Server, select the check box to enable a fixed UDP Destination Port.

### UDP Destination Port

When using UDP Server with a Fixed UDP Destination Port, enter the port number.

### Fixed UDP Source Port

When using UDP Client, select the check box to enable a Fixed UDP Source Port.

### UDP Source Port

When using UDP Client with a fixed UDP Source Port, enter the port number.

3. When you have finished making changes, click **Update All** to save all pending changes, click **Reset All** to revert to all previously saved values, and click **Reset Page** to revert to previous saved values on the current page.

## Ethernet | Ethernet\_IP

Use the **Ethernet I/P** window to set up digital inputs and outputs for the barcode scanner.

**To enable or disable Ethernet/IP:**

1. In the menu under **Modify Settings**, navigate to **Global Settings | Ethernet | Ethernet/IP**. The Ethernet/IP window opens.

2. Enter the appropriate information in the form as described below:

### Enable Ethernet/IP

Select the check box to enable Ethernet/IP and reveal the related configuration options.

### Heartbeat Enable

Select from the drop-down; Disable, Enable Unconditioned, or Enable Conditioned.

### Heartbeat Settings Heartbeat Timeout

Enter a time value in seconds to define the amount of time between two message transmissions. If the input timeout expires and no transmission has occurred, the Heartbeat message will be transmitted.

### Heartbeat Message (max.32 chars)

Click  to activate the Text Entry Tool and create heartbeat header text to signal the beginning of the heartbeat message. Characters from NUL (00H) to ~ (7EH) can be used.

The Heartbeat Message (header) string must be different from the Heartbeat Terminator string.

### Heartbeat Terminator (max.32 chars)

Click  to activate the [Text Entry Tool](#) and create Heartbeat Terminator text to signal the end of the heartbeat message. Characters from NUL (00H) to ~ (7EH) can be used.

The Heartbeat Terminator string must be different from the Heartbeat Message (header) string.

### Send Failure Bitmap

Select the check box to include a Failure Bitmap in the heartbeat message.

### Failure Bitmap Format

Select the format of the Failure Bitmap from the drop-down. Options are; Decimal (ASCII), Hexidecimal (ASCII), Bitmap (ASCII) and Numeric (Binary).

**Failure Bitmap Size**

Select the size of the Failure Bitmap from the drop-down. Options are; Variable, or 1-32.

**Ethernet/IP Object Selection**

Select DLA Object or ASI Object from the drop-down list.

**DLA Object** – Refers to Datalogic Devices

**ASI Object** – Refers to legacy Accu-Sort Devices

**DLA Object: Digital Input Lines**

Ethernet/IP	
Enable Ethernet/IP	<input checked="" type="checkbox"/>
Heartbeat Enable	Disable
Ethernet/IP Object Selection	DLA Object

Digital Input Lines	
Trigger (Input 1) Echo	Enable
Aux (Input 3) Echo	Disable
I/O 4 (Input 4) Echo	Disable
Phase Echo	Disable

Digital Output Lines	
Control Output 1	Disable
Control Output 2	Disable
Control Output 3	Disable
Control Output 4	Disable

Update All    Reset All    Reset Page

**Trigger (Input 1) Echo**

Select Disable or Enable from the drop-down list. If enabled, the Scanner Master or SC5000 Controller Trigger (Input 1) status is echoed to the Ethernet Client via bit 0 in Byte InputBits of the DL\_InputStruct.

**Aux (Input 3) Echo**

Select Disable or Enable from the drop-down list. If enabled, the Scanner Master or SC5000 Controller Input 3 status is echoed to the Ethernet Client via bit 2 in Byte InputBits of the DL\_InputStruct.

**I/O 4 (Input 4) Echo**

Select Disable or Enable from the drop-down list. If enabled, the Scanner Master or SC5000 Controller Input 4 status is echoed to the Ethernet Client via bit 3 in Byte InputBits of the DL\_InputStruct.

**Phase Echo**

This parameter is configurable only if Start Input from Bus is enabled.

Select Disable or Enable from the drop-down list. If enabled, the Reading Phase status is echoed to the Ethernet Client via bit 7 in Byte InputBits of the DL\_InputStruct.

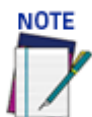

**ASI Object: On Demand Options**

Contact Datalogic Support for information on setting up ASI Objects (legacy Accu-Sort Devices). See [Support Through the Website](#)

**Ethernet/IP Object Selection**

Select DLA Object or ASI Object from the drop-down list.

**DLA Object** – Refers to Datalogic Devices

**ASI Object** – Refers to legacy Accu-Sort Devices

**Enable ControlLogix On-Demand Messaging**

Select the check box to enable On-Demand Messaging when ASI Object is selected.

**ASI Object: On -Demand Options**  
**Message Format**

**On-Demand Messaging** is a special option for communicating with ControlLogix/ CompactLogix Controllers. When enabled, you must provide the Controller IP Address, the Slot number of the processor in the Controller and a Tag Name. To use On-Demand messaging, a tag of the same name is then defined on the ControlLogix/CompactLogix Controller and every time a bar code is read, the Bar Code object is transferred to the ControlLogix/CompactLogix Tag.

**PLC IP Address**

Enter the IP Address for the PLC Controller (Rockwell Automation: Allen-Bradley ControlLogix or CompactLogix).

**Tag Name**

Enter a tag name (up to 40 characters) in the field provided.

**PLC Slot Number**

Enter the PLC Slot number in the field provided. This corresponds to the physical slot used on the PLC.

**ASI Object: Message Options****Message Format**

Select ASCII or Binary from the drop-down list.

**ASCII** – Select to transmit an ASCII barcode message (as defined by the Message Type). The only difference is that the Header and Trailer are omitted from the barcode messages transmitted using EtherNet/IP. When ASCII messages are in use, the Byte Swap ASCII Data selection will swap the high and low byte of data within each 16 bit word. This is useful for processing data on some Programmable Controllers.

**Binary** – Select to convert barcode data to a “numeric value” and transferred

as a 32 bit word. The user can specify the byte ordering of this word. If any non-numeric (not ASCII '0' to '9' or leading or trailing space) characters are contained in the barcode, the numeric value is zero.

### ASCII Message Byte Swap

Select the check box to enable the function. Available when Binary is selected from the Message Format drop-down list. When ASCII messages are in use, the ASCII Message Byte Swap selection will swap the high and low byte of data within each 16 bit word. This is useful for processing data on some Programmable Controllers.

### Binary Message Byte Order

Select Little Endian or Big Endian from the drop-down list. Available when Binary is selected from the Message Format drop-down list.

**Little Endian:** The least significant byte (little end) of the data is positioned at the byte with the lowest address.

**Big Endian:** The most significant byte (big end) of the data is positioned at the byte with the lowest address.

### Digital Output Lines Control Output 1

This parameter is configurable only if Digital Output 1 Use is set to EthernetIP. Select Disable or Enable from the drop-down list. If enabled, it allows the Ethernet Client to drive the Scanner Master or SC5000 Controller Output 1 via bit 0 in Byte OutputBits of the DL\_OutputStruct.

Digital Output Lines

Select Digital Output Number to View/Modify: 1

Digital Output 1

Digital Output 1 Use: EthernetIP

Digital Output 1 Line State: Normally Open

Update All   Reset All   Reset Page

### Control Output 2

This parameter is configurable only if Digital Output 2 Use is set to EthernetIP. Select Disable or Enable from the drop-down list. If enabled, it allows the Ethernet Client to drive the Scanner Master or SC5000 Controller Output 2 via bit 1 in Byte OutputBits of the DL\_OutputStruct.

3. When you have finished making changes, click **Update All** to save all pending changes, click **Reset All** to revert to all previously saved values, and click **Reset Page** to revert to previous saved values on the current page. 0.

# Ethernet | WebSentinel

Use the **WebSentinel** window to enable and configure the barcode scanner for use with Datalogic WebSentinel™. WebSentinel PLUS is an advanced monitor and information collector. It offers key features, benefits, and insights to end-users and System Integrators specializing in Factory Automation and Transportation and Logistics. It is built on the large Datalogic experience in T&L applications and provides real-time statistics, diagnostics, quick viewing of parcel activity, and reporting capabilities.

To enable or disable WebSentinel:

1. In the menu under **Modify Settings**, navigate to **Global Settings | Ethernet | WebSentinel**. The WebSentinel window opens.

**WebSentinel**

Enable

WebSentinel Socket User Socket 4 ▼

**Monitor Settings**

Conveyor Speed Check Type Percent ▼

Maximum Conveyor Speed Percent Error (%) 5

Input Timeout (secs) 3 sec

**Message Settings**

Parcel Message Type Standard ▼

WebSentinel - Partial Read Is Treated As Good Read ▼

Update All Reset All Reset Page



Access the WebSentinel QuickStart Guide.

**NOTE**

Site View

Global Settings

Local Settings

User Profile Settings

Troubleshooting

Help

- Help
- About
- License Agreement (EU)
- Quick Start Guide

WebSentinel PLUS QuickStart

Introduction

WebSentinel PLUS is a browser-based application that gives facility managers and engineers unparalleled ability to monitor multiple conveyor systems and their goods which they apply or access multiple facilities from wherever an internet connection is available. WebSentinel PLUS provides real time and historical performance data of all easy to use browser-based interface, as well as automatic status and error condition reporting of all Datalogic products and systems to which it is connected.

- Check Prerequisites
- Quick Start Guide for setting up the WebSentinel PLUS
- Common Datalogic Devices to WebSentinel PLUS

The installed barcode readers, cameras, dimensions, and cameras communicate with the WebSentinel PLUS Server through the site local area network. Once WebSentinel PLUS then stores up to 45 days' worth of site data in its database. See "Typical WebSentinel PLUS configuration" example below.

A static IP address (LAN) is assigned to the non-wired WebSentinel PLUS Server, and you can access the application through any internet browser that has access to that network. To access the application WebSentinel PLUS Server IP address with the browser's address field, you can log on to the WebSentinel PLUS Login window. With a proper user ID and password, you can log in and begin monitoring the scan points at your facility.

2. Enter the appropriate information in the form as described below:

## Enable

Select the check box to enable WebSentinel and reveal the related configuration options.

## WebSentinel Socket

Select a socket number for WebSentinel from those available in the drop-down list.

### Monitor Settings

#### Conveyor Speed Check Type

Select Percentage or Absolute from the drop-down list to determine how the conveyor speed is evaluated.

#### Max Conveyor Speed Percent Error (%)

In the text field provided, enter the percentage of discrepancy allowed in the conveyor speed before an error is sent. This option is available when Percentage is selected from the Conveyor Speed Check Type drop-down list.

#### Max Conveyor Speed Absolute Error (mm/s)

In the text field provided, enter the milliseconds of discrepancy allowed in the conveyor speed before an error is sent. This option is available when Absolute is selected from the Conveyor Speed Check Type drop-down list.

#### Input Timeout (secs)

Enter a time interval in seconds, after which the input will be checked for errors. If an error is found, it will be sent to WebSentinel.

### Message Settings

#### Parcel Message Type

Select Standard, Extended, or Extended ADP from the drop-down to specify the type of message.

**Extended** – WebSentinel PLUS versions earlier than 1.6.0.1369

**Extended ADP** – WebSentinel PLUS versions 1.6.0.1369 and later

#### WebSentinel – Partial Read Is Treated As

Select No Read or Good Read from the drop-down to specify how a partial read is treated.

3. When you have finished making changes, click **Update All** to save all pending changes, click **Reset All** to revert to all previously saved values, and click **Reset Page** to revert to previous saved values on the current page.

## Fieldbus

Use the **Fieldbus** window to configure Fieldbus type communication between the scanner and Host, or, in a multi-sided layout, between several scanners and a Host.

To edit the Fieldbus settings:

1. In the menu under Modify Settings, navigate to **Global Settings | Fieldbus**. The Fieldbus window opens.

2. Enter the appropriate information in the form as described below:

### Fieldbus Type

Fieldbus type is displayed. When using the CBX510 with Fieldbus modules, select the correct Fieldbus Type. For SC5000, this option is preset and read-only based on the controller model used.



**The Fieldbus is only available on specific models of the SC5000.**

### Data Tx

Select Enable or Disable from the drop-down list. If enabled, the fieldbus port is used by the scanner to transmit data and/or messages.

### Heartbeat

Select Disable, Enable Unconditioned, or Enable Conditioned from the drop-down list.

This parameter is available when the Data TX parameter is checked. It enables/disables the transmission of the Heartbeat message signaling that the device is still active.

**Disable:** The Heartbeat message is not transmitted

**Enable Unconditioned:** The Heartbeat message is always transmitted, even if communication is still active

**Enable Conditioned:** The Heartbeat message is transmitted only when there is no communication

### Heartbeat Settings

**Heartbeat Settings**

Heartbeat Timeout  sec

Heartbeat Message (max. 32 chars)  

Heartbeat Terminator (max. 32 chars)  

#### Heartbeat Timeout

Enter a time value in seconds to define the amount of time between two message transmissions. If the input timeout expires and no transmission has occurred, the Heartbeat message will be transmitted.

#### Heartbeat Message (max. 32 chars)

Click  to activate the Text Entry Tool and create heartbeat header text to signal the beginning of the heartbeat message. Characters from NUL (00H) to ~ (7EH) can be used.

The Heartbeat Message (header) string must be different from the Heartbeat Terminator string.

#### Heartbeat Terminator (max. 32 chars)

Click  to activate the Text Entry Tool and create Heartbeat Terminator text to signal the end of the heartbeat message. Characters from NUL (00H) to ~ (7EH) can be used.

The Heartbeat Terminator string must be different from the Heartbeat Message (header) string.

#### Send Failure Bitmap

Select the check box to include a Failure Bitmap in the heartbeat message.

#### Failure Bitmap Format

Select the format of the Failure Bitmap from the drop-down. Options are; Decimal (ASCII), Hexidecimal (ASCII), Bitmap (ASCII) and Numeric (Binary).

#### Failure Bitmap Size

Select the size of the Failure Bitmap from the drop-down. Options are; Variable, or 1-32.

### Flow Control Settings

#### Baud Rate

This is a read-only parameter. The default value Auto allows the Host to control the data transmission speed of the Profibus network.

#### Data Flow Control

Select Disable, DAD Driver, or DPD Driver from the drop-down list. This implements a reliable transmission protocol between Fieldbus Master (PLC) and Fieldbus Slave (SC5000 or Scanner Master) allowing specific functions such as Synchronization, Fragmentation/Reassembling and Data Consistency

#### Consistency

Select Disable or Enable from the drop-down list. This parameter is available only when the Data Flow Control parameter is set to DAD or DPD Driver. If enabled, it allows improving the overall communication robustness of the Fieldbus network.

---

**Profibus Settings, Profibus SC5000 Redundant (SC5000 Profibus models)****Node Address**

Enter a Node Value in the field provided, to define the value that distinguishes this node from all other nodes on the same link. Each node identifies a device within the network.

Valid values are in the range 0 – 126.

Node Address 126 forces the SSA (Set Station Address) service which allows the Fieldbus Master to assign the slave node address.

**Node Address (Working/ Protecting) SC500 Redundant**

Enter a Node Value in the fields provided, to define the value that distinguishes these nodes from all other nodes on the same link. Each node identifies a device within the network. The behavior is controlled by the IP Selector parameter in Modify Settings | Global Settings | Redundant Operation.

Valid values are in the range 0 – 126.

Node Address 126 forces the SSA (Set Station Address) service which allows the Fieldbus Master to assign the slave node address.

**Master Input Area Size**

Enter a value from 8 – 144 bytes to define the size of the message command sent from the Fieldbus module to the Fieldbus Master (Host). The default value is 8 bytes.

The maximum Input + Output Area Size for the Profibus interface is 152 bytes.

**Master Output Area Size**

Enter a value from 8 – 144 bytes to define the size of the message command sent to the Fieldbus module from the Fieldbus Master (Host). The default value is 8 bytes.

The maximum Input + Output Area Size for the Profibus interface is 152 bytes.

**MAC Address**

This is a read-only parameter. It displays the address of the Profinet channel reserved for internal communication.

### MAC Address 1

This is a read-only parameter. It displays the address of the Profinet channel reserved for internal communication.

### MAC Address 2

This is a read-only parameter. It displays the address of the Profinet channel reserved for internal communication.

### Ethernet Bus Rate

This is a read-only parameter. The bus rate is set to Auto allowing the Host to manage the bus speed.

### **Set by Network Station Name**

Enter the name of the station.

### IP Addressing

**Static:** the IP Address can be set manually through the IP Address, IP Net Mask and IP Gateway parameters.

**DHCP:** the IP address is assigned by a DHCP server. In this case the IP Address parameters are read-only and display the DHCP assigned address.

**Remote:** the IP Address is assigned by a remote network device (PC) using an IPConfig address configuration application. In this case the IP address parameters are read-only and display the remotely assigned address.

### IP Address

Enter the device **Internet Protocol (IP)** network address in the field provided. Consult your network administrator to obtain a new address.

### IP Net Mask

Enter the device **Subnet Mask Address** in the field provided. Consult your network administrator to obtain a new address.

### IP Gateway

Enter the device **Gateway Address** in the field provided. Consult your network administrator to obtain a new address.

### **Digital Input Lines**



If any of the following parameters are enabled, the Data Flow Control DAD/DPD Driver starts at Byte 1 (second byte) of the Fieldbus Master Input Area, and Byte 0 (first byte) is reserved for Digital Input Line Echo parameters. If none of the following parameters are enabled, the Data Flow Control DAD/DPD Driver starts at Byte 0 (first byte) of the Fieldbus Master Input Area. For more details, refer to the DAD/DPD Driver Reference Manual

### Trigger (Input 1) Echo

Select Disable or Enable from the drop-down list. If enabled, the Scanner Master or SC5000 Controller Trigger (Input 1) status is echoed to the Fieldbus Master via bit 0 in Byte 0 (first byte) of the Input Area.

### Aux (Input 3) Echo

Select Disable or Enable from the drop-down list. If enabled, the Scanner Master or SC5000 Controller Input 3 status is echoed to the Fieldbus Master via bit 2 in Byte 0 (first byte) of the Input Area.

### I/O 4 (Input 4) Echo (SC5000 Only)

Select Disable or Enable from the drop-down list. If enabled, the SC5000 Controller Input 4 status is echoed to the Fieldbus Master via bit 3 in Byte 0 (first byte) of the Input Area.

### Phase Echo

This parameter is configurable only if Start Input from Bus is enabled.

Select Disable or Enable from the drop-down list. If enabled, the Reading Phase status is echoed to the Fieldbus Master via bit 7 in Byte 0 (first byte) of the Input Area.



## Digital Output Lines

### Control Output 1

This parameter is configurable only if Digital Output 1 Use is set to Profibus/Profinet. Select Disable or Enable from the drop-down list. If enabled, it allows the Fieldbus Master to drive the Scanner Master or SC5000 Controller Output 1 via bit 0 in Byte 0 (first byte) of the Output Area.

### Control Output 2

This parameter is configurable only if Digital Output 2 Use is set to Profibus/Profinet. Select Disable or Enable from the drop-down list. If enabled, it allows the Fieldbus Master to drive the Scanner Master or SC5000 Controller Output 2 via bit 1 in Byte 0 (first byte) of the Output Area.

3. When you have finished making changes, click **Update All** to save all pending changes, click **Reset All** to revert to all previously saved values, and click **Reset Page** to revert to previous saved values on the current page.

## Messaging

Use the Messaging selections during initial setup to configure system messaging for your system. If necessary you can later make modifications to the configuration using the same menu selections, including:

“Messaging | Message Format” on page 127

“Messaging | Message Builder” on page 139

“Messaging | Statistics” on page 145

“Messaging | Protocol Index” on page 147

“Messaging | Pass-Thru” on page 151

“Messaging | Diagnostics Messages” on page 153

# Messaging | Message Format

Use the **Message Format** window to configure Standard or Advanced system messages.

**To edit the Message Format settings:**

1. In the menu under Modify Settings, navigate to Global Settings | Messaging | Message Format. The Message Format window opens.

2. Enter the appropriate information in the form as described below:

## **Messaging Formatting** **Special Host Protocol**

Select None or a specific custom protocol from the drop-down list. In some cases, a customer specific protocol may have been created. When selected, a group of optionsspecific to that protocol are made available.

**None**  
**Crisplant**  
**Mettler Toledo**

## **Message Format**

Select [Standard](#), or [Advanced](#) from the Format Type drop-down list.

Standard: All ports will transmit using the standard Format parameters.

Advanced: 5 different formats are configurable. These options are selected under the Advanced Format option.



**The User Socket must be selected under Ethernet > User Sockets to be available.**

**SPECIAL HOST PROTOCOL: NONE**

**Format Type: Standard**

**Header String (max. 128 chars.)**

Click  to activate the Text Entry Tool and create a Header String in the text field provided. Headers (up to 128 bytes) can be defined and transmitted as a block preceding the barcode(s). Use characters from NUL (00H) to ~ (7EH).

Click Submit to save your text to the origin window text field, or click Cancel to return to origin window without transferring text.

**Termination String (max. 128 chars.)**

Click  to activate the Text Entry Tool and create a Termination String in the text field provided. Terminators (up to 128 bytes) can be defined and transmitted as a block following the barcode(s). Use characters from NUL (00H) to ~ (7EH). Click Submit to save your text to the origin window text field, or click Cancel to return to origin window without transferring text.

**Data Packet Separators (max. 128 chars.)**

Click  to activate the Text Entry Tool and create a Data Packet Separators in the text field provided. The Data Packet Separators (up to 128 bytes) are used to separate barcodes in the reading phase. Use characters from NUL (00H) to ~ (7EH).

For this reason, it is very useful when the Standard Multi Label, Code Collection or Code Combination parameters have been selected in the Barcode Configuration. If selected, they occur within the Code Field and are transmitted after each decoded code.

Click Submit to save your text to the origin window text field, or click Cancel to return to origin window without transferring text.

**Code Position Tx**

Select the check box to enable. If enabled, the code position information is included in the output data format.

**Code Direction Identifier Enable**

Select the check box to enable. If enabled, it allows you to define the forward and reverse strings indicating the scanning direction with respect to the code direction.

Code Direction Identifier Enable	<input checked="" type="checkbox"/>
Forward Direction String	<input type="text" value="+"/>
Reverse Direction String	<input type="text" value="-"/>
Unknown Direction String	<input type="text" value="/"/>
Code Field Length Setting	Variable Length
Code Identifier	Disabled

**Forward Direction String (max. 32 chars.)**

Click  to activate the Text Entry Tool and create a Forward Direction String in the text field provided. A Forward Direction String can be included in the output message to indicate that the current code has been scanned in the forward direction (scanning from left to right). This string ("+" is the default value) can be customized by the user including up to 32 characters.

Click Submit to save your text to the origin window text field, or click Cancel to return to origin window without transferring text.

**Reverse Direction String (max. 32 chars)**

Click  to activate the Text Entry Tool and create a Reverse Direction String in the text field provided. A Reverse Direction String can be included in the output message to indicate that the current code has been scanned in the reverse direction (scanning from right to left).

The string ("-") is the default value) can be customized by the user including up to 32 characters.

Click Submit to save your text to the origin window text field, or click Cancel to return to origin window without transferring text.

**Unknown Direction String (max. 32 chars.)**

Click  to activate the Text Entry Tool and create an Unknown Direction String in the text field. An Unknown Direction String can be included in the output message when it is not possible to determine the scanning direction of a code. The string ("?" is the default value) can be customized by the user including up to 32 characters.

Click Submit to save your text to the origin window text field, or click Cancel to return to origin window without transferring text.

**Code Field Length Setting**

Select **Variable** or **Fixed** from the drop-down list. If Variable is chosen, all possible code field lengths (in number of characters/digits) allowed for the code selected are accepted. If Fixed is chosen, only the length defined by the Code Field Length parameter is accepted.

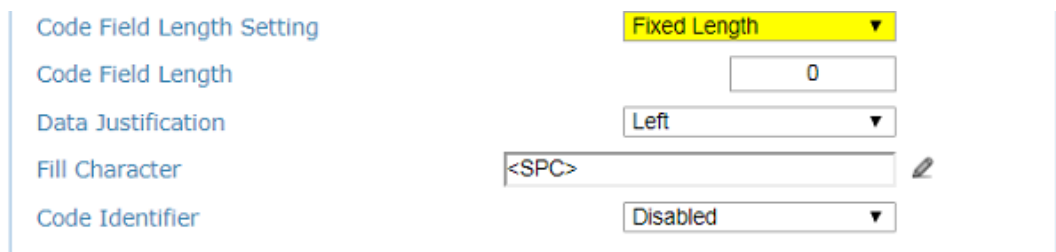

**Code Field Length**

This parameter is only available when **Fixed** is selected as the Code Field Length Setting. Enter length of the code field to be transmitted (in number of characters/digits) in the field provided.

Enter a length in the field provided. This parameter is applied only to the <Barcode> field contained in two specific messages (Barcode information and Diagnostics) of the protocol. It is available when the Code Field Length Setting is set to Fixed.

This defines (in number of characters/digits) the length of the <Barcode> field to be transmitted in a value range from 0 to 48.

**Data Justification**

This parameter is only available when **Fixed** is selected as the Code Field Length Setting. Select Left or Right from the drop-down list. This parameter is applied only to the <Barcode> field contained in two specific messages (Barcode information and Diagnostics) of the protocol. This defines the position of the Fill Character within the code:

- Left:** Fill Character is left aligned and precedes the <Barcode> field
- Right:** Fill Character is right aligned and follows the <Barcode> field

**Fill Character**

This parameter is only available when **Fixed** is selected as the Code Field Length Setting. Click  to activate the Text Entry Tool and create a fill character in the field provided. This parameter is applied only to the <Barcode> field contained in two specific messages (Barcode information and Diagnostics) of the protocol. It is available when the Code Field Length Setting is set to Fixed. The Fill Character is inserted into each character position of a code field that has more characters (as defined in the Code Field Length) than exist in the barcode read. A character from NUL (00H) to ~ (7EH) can be used.

Click Submit to save your changes, or click Cancel to return to previous.

**Code Identifier**

Select Disable, Standard AIM ID, or User Specified from the drop-down list. A Code Identifier string can be included in the output message.

- If **Disable** is selected, no code identifier is included in the output message.
- If **Standard AIM ID** is selected, the AIM standard identifier is included in the output message
- If **User Specified** is selected, the Code Identifier Strings group is activated at the bottom of the window, allowing you to define an identifier string for each code symbology. The string will be included in the output message.

**Code Identifier Strings**

This section of the Message Format window is only available when **User Specified** is selected as the Code Identifier. Click  to activate the Text Entry Tool and create a custom code identifier string for any listed code symbology. Click Submit to save your text to the origin window text field, or click Cancel to return to origin window without transferring text.

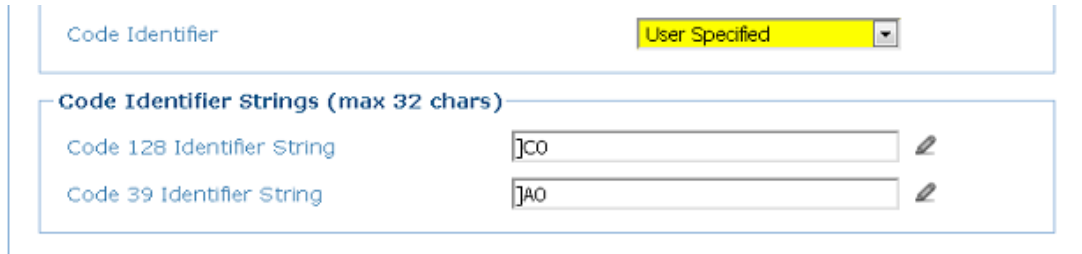

**SPECIAL HOST PROTOCOL: CRISPLANT PROTOCOL**

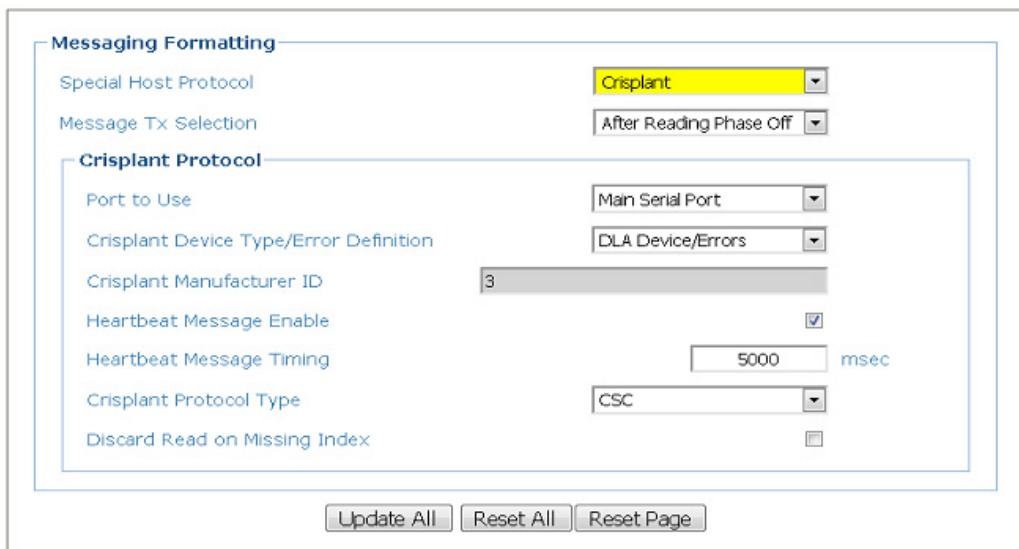

**Port to Use**

Select **Aux Serial Port, Main Serial Port, User Socket (1–6), or Fieldbus** from the drop-down list.

**Crisplant Device Type/Error Definition**

Select **DLA Device/Errors** or a **ASI-Axiom/Errors** from the drop-down list. This allows selection of different device types, as the error codes required by Crisplant vary from device to device.

- DLA Device/Errors:** select when using current Datalogic devices
- ASI-Axiom/Errors:** Select when using legacy Accu-Sort devices

**Crisplant Manufacturer ID**

This field is determined by the Crisplant Device Type/Error Definition selected above and cannot be edited.

This defines the "Scanner Identity" byte of the Error and Heartbeat messages of the Crisplant Protocol.

**Heartbeat Message Enable**

Select the check box to enable the transmission of the Heartbeat message.

**Heartbeat Message Timing**

Enter a value in milliseconds to define the amount of time between two code transmissions. If the selected timeout expires and no transmission has occurred, the Heartbeat message will be transmitted.

### Crisplant Protocol Type

Select CSC, CMC, or P10 from the drop-down list. This defines the type of Crisplant protocol to be used:

**CSC:** the <CR><LF> characters do not appear at the end of transmitted/received telegrams

**CMC:** the <CR><LF> characters appear at the end of transmitted/received telegrams

**P10:** the <CR><LF> characters appear at the end of transmitted/received telegrams

The Parameter Crisplant Manufacturer ID is forced to the Value 'a' (61H) and cannot be modified for this selection, the error messages are modified with respect to CSC and CMC protocols

### Discard Read on Missing Index

Select the check box to enable. When selected, if a Missed Index error occurs, an empty telegram is sent to the Crisplant Host.

If not selected, and a Missed Index error occurs, the telegram contains the codes that were read relative to the pack.

**SPECIAL HOST PROTOCOL: METTLER TOLEDO PROTOCOL**

**Messaging Formatting**

Special Host Protocol Mettler Toledo

**Mettler Toledo Protocol**

Conveyer Direction Input Aux (Input 3)

SW Divide Encoder Frequency

**Message Definition**

Header

Trailer

Heartbeat Enable

Heartbeat Timeout  maec

Heartbeat Message

Code Field Length Setting Variable Length

Add AIM Prefix

AM/PM Behavior

Multi-Tx Transport Disable

Spontaneous Status Message

Purolator Custom Check

**Code Filters**

Enable UPS Code Filter

**UPS Code Filters**

Tracking Label - Starts with '12'

Service Upgrade Label - Starts with '403', Length is 8

**PTN Code Filters**

Select all codes of PTN type, except codes below (that must be selected)

Starts with '400'

Starts with '420'

Starts with '421'

Starts with '51L'

Starts with '52L'

Starts with '54L'

Starts with '55L'

**Postal Code Filters**

Starts with '420', Length is 8 or 12

Starts with '421', Length from 6 to 15

Starts with '51L', Length is 8, 9 or 12

Starts with '52L', Length is 8, 9 or 12

Starts with '54L', Length is from 6 to 19

Starts with '55L', Length is from 6 to 19

**Diagnostic Messages**

Main Serial Port	<input type="checkbox"/>	Aux Serial Port	<input type="checkbox"/>	User Socket 1	<input type="checkbox"/>
User Socket 2	<input type="checkbox"/>	User Socket 3	<input type="checkbox"/>	User Socket 4	<input type="checkbox"/>
User Socket 5	<input type="checkbox"/>	User Socket 6	<input type="checkbox"/>		

**Debug Messages**

Main Serial Port	<input type="checkbox"/>	Aux Serial Port	<input type="checkbox"/>	User Socket 1	<input type="checkbox"/>
User Socket 2	<input type="checkbox"/>	User Socket 3	<input type="checkbox"/>	User Socket 4	<input type="checkbox"/>
User Socket 5	<input type="checkbox"/>	User Socket 6	<input type="checkbox"/>		

This protocol is a standard interface for Mettler Toledo precision scales and balancers.



### Conveyer Direction Input

Select Trigger (Input 1) or Aux (Input 3) from the drop-down list. The selection defines which digital input transmits information about the conveyer direction. The conveyer direction is Forward when the selected input is active (default active closed). If Input 1 is used the scanner Phase On LED also signals the direction state.

### SW Divide Encoder Frequency

Select the check box to enable. If selected, the encoder frequency value is divided by two before it is transmitted to the Host. This parameter only effects the value contained in the <Encoder> field of the messages sent from the scanner to the Host.

### **Message Definition Header**

Enter a message header in the field provided. A Header (up to 128 bytes) can be defined and transmitted as a block preceding all messages sent from the scanner. Character from NUL (00H) to ~ (7EH) can be used.

### Trailer

Enter a message trailer in the field provided. A Trailer (up to 128 bytes) can be defined and transmitted as a block following all messages sent from the scanner. Character from NUL (00H) to ~ (7EH) can be used.

### Heartbeat Enable

Select the check box to enable heartbeat.

### Heartbeat Timeout

Enter a value in milliseconds. This parameter is available when the Heartbeat parameter is enabled. It defines the amount of time between two message transmissions. If the selected timeout expires and no transmission has occurred, the Heartbeat message will be transmitted.

### Heartbeat Message

Click  to activate the Text Entry Tool and create a heartbeat message in the field provided. This parameter is available only when the Heartbeat parameter is enabled. This defines the Heartbeat message.

Click Submit to save your changes, or click Cancel to return to previous.

### Code Field Length Setting

Select Fixed Length or Variable Length from the drop-down list. This parameter is applied only to the <Barcode> field contained in two specific messages (Barcode information and Diagnostics) of the protocol. The code field length (in number of characters/digits) can be specified in order to be transmitted:

**Variable:** All possible code field lengths (in number of characters/digits) allowed for the code selected are accepted

**Fixed:** The code is entirely transmitted even if it is longer than the defined length. If shorter, it will be transmitted with the addition of the Fill Character.

### Add AIM Prefix

Select check box to enable. If enabled, it adds the AIM standard prefix to the barcode to be sent to the host. No separator character will be added between the AIM prefix and the barcode.

### AM/PM Behavior

Select the check box to enable. If enabled, the Host is ready to receive the following message:

<STX><COMMAND><ETX>

where:

<COMMAND> = 'A' indicates that the Host starts working in AM mode / 'P' indicates that the Host starts working in PM (default) mode

When working in AM mode:

each code is only filtered by the Encoder Timeout parameter;

the Purolator Custom Check parameter is not effective; the Heartbeat message will never be transmitted; the transmitted message is not subject to padding with the Fill Character and the output message format is the following:

<STX><scanner\_nr><space><barcode><ETX><CR><LF>

where:

<scanner\_nr> = 2-digit number in the range 00–31

### **AM Message Target**

Select **Main Serial Port**, **Aux Serial Port**, or a **User Socket** from the drop-down list.

### **Multi-Tx Transport Disable**

This parameter manages the message transmission through the different communication channels.

If unchecked (check box not selected), messages are transmitted through all the communication channels having the Data Tx parameter enabled.

If checked (check box selected), messages are sent through all the communication channels having the Data Tx parameter enabled until the scanner receives one of the three possible communication messages (Status Request, Encoder Counter Request, Initialization Command). As soon as this condition occurs, all messages will be transmitted only through the specific channel sending one of the three possible communication messages while other channels are ignored. In this way, the last channel sending one of the possible communication messages will become the one used for transmission.

### **Spontaneous Status Message**

Select check box to enable. In case of diagnostic errors, this message is sent every 40 seconds.

### **Purolator Custom Check**

Select the check box to enable. If enabled, all service labels sharing the following characteristics will not be filtered by the Code Filter Depth and Encoder Timeout parameters:

- all service labels containing 2 characters only (e.g. "F1", "F2", ecc);
- all service labels of 8 characters starting with "ENP";
- all service labels of 9 characters starting with "OSNR".

### **Code Filter**

#### **Enable UPS Code Filter**

Select the check box to enable. If selected, the UPS Code Filters, PTN Code Filters, and Postal Code Filters panels open.

### **UPS Code Filters**

#### **Tracking Label – Starts with '1Z'**

Select check box to enable. If selected, function allows the transmission of codes belonging to the Code 128 and Code 39 families starting with '1Z', '3Z', '1B' or '3B'. The length of these codes is 18 digits.

#### **Service Upgrade Label – Starts with '403', Length is 8**

Select check box to enable. If selected, function allows the transmission of codes belonging to the Code 128 and Code 39 families starting with '403'. The length of these codes is 8 digits.

### **PTN Code Filters**

Select all codes of PTN type, except codes below (that must be selected)

Select check box to enable. If selected, it is possible to transmit all Code 128 and Code 39 codes belonging to this type having a length of 11 digits with the exception of those starting with:

- '400', '420', '421', '51L', '52L', '54L', '55L'

Starts with...

Select each check box to enable/include that prefix.

### **Postal Code Filters**

#### **Starts with...**

Select each check box to enable/include that prefix. This allows the transmission of codes belonging to the Code 128 and Code 39 families having any of the following selected characteristics:

- starting with '420' and with length 8 or 12 digits
- starting with '421' and with length from 6 to 15 digits

starting with '51L' and with length 8, 9 or 12 digits  
starting with '52L' and with length 8, 9 or 12 digits  
starting with '54L' and with length from 6 to 19 digits  
starting with '55L' and with length from 6 to 19 digits

### **Diagnostic Messages**

Select the check boxes as needed to enable. If selected, these parameters allow selecting the desired communication channel (Main, Aux, User Socket#n) to be used for transmitting barcode messages coming from slaves.

The selection is available only if the desired communication channel is free (Data TX parameter disabled).

The diagnostic data format can be defined through the commands provided by a terminal interface.

### **Debug Messages**

Select the check boxes as needed to enable. If selected, these parameters allow selecting the desired communication channel (Main, Aux, User Socket#n) to be used for transmitting debug messages coming from slaves.

The selection is available only if the desired communication channel is free (Data TX parameter disabled).

### **DPD Code Filters**

If DPD Code Filter is enabled, the user can select the DPD code to be transmitted by selecting its check box. All codes different from the selected DPD will also be transmitted.

This group allows selecting the DPD code type(s) to be transmitted. These codes belong to the Interleaved 2/5 or Code 128 family and have one of the following characteristics:

12of5 Code, Length is 10

12of5 Code, Length is 12

12of5 Code, Starts with '0', Len"Special Host Protocol: None" on page 136gth is 4

12of5 Code, starts with '90',Length is 4

Code 128, Length is 28

All codes belonging to code families other than Interleaved 2/5 and Code 128 will also be transmitted.

**SPECIAL HOST PROTOCOL: NONE**  
**Format Type: Advanced**

**Messaging Formatting**

Special Host Protocol: None

Message Format: Advanced

Message Tx Selection: After Reading Phase Off

Maximum Tx Delay after Phase Off: 100 msec

Header Tx Start: With Data

Termination After No Read Message: Enable

---

**Advanced Format**

Select an Message Number to Modify: 1

---

**Advanced Format: Message Definition 1**

**Message Destination**

Main Serial Port <input type="checkbox"/>	Aux Serial Port <input type="checkbox"/>	User Socket 1 <input checked="" type="checkbox"/>
User Socket 2 <input type="checkbox"/>	User Socket 3 <input type="checkbox"/>	User Socket 4 <input type="checkbox"/>
User Socket 5 <input type="checkbox"/>	User Socket 6 <input type="checkbox"/>	EtherNet/IP <input type="checkbox"/>
Profibus <input type="checkbox"/>	Profinet <input type="checkbox"/>	

Message Destination Bitmap: 8192

Message Alignment: None

Header: <STX> ✎

Terminator: <ETX> ✎

Message Location for Global No Read: Only No Read Message

Global Scale Type (Units): Metric (mm)

Code Identifier: AIM

[Message Builder](#)

Update All
Reset All
Reset Page

**Message Tx Selection**

Select On Decoding or After Reading Phase Off from the drop-down list. Message Tx selects the transmission of the output message on decoding or after the reading phase as illustrated below. This option is only available when Operation Mode is set to On Line.

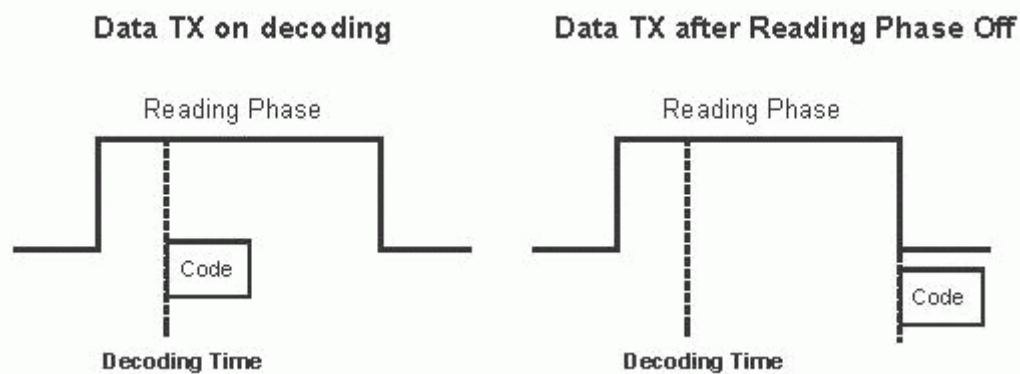

This option is only available when an **Operating Mode** of **On Line** is selected in **Modify Settings | Global Settings | Operating Mode**.

**Max. Tx Delay after Phase Off**

Select Disabled or a millisecond value (50 to 500 msec) from the drop-down list. This parameter defines a timeout, which is the maximum delay allowable for message transmission after the reading phase is closed. If this timeout expires before message transmission, the message will be discarded.



This option is only available when an **Operating Mode of On Line** is selected in **Modify Settings | Global Settings | Operating Mode**.

**Header Tx Start**

Select With Data or After Reading Phase On from the drop-down list. If With Data is selected, the header will be transmitted with data. If After Reading Phase On is selected, the header will be transmitted after the reading phase activation. See illustration below:

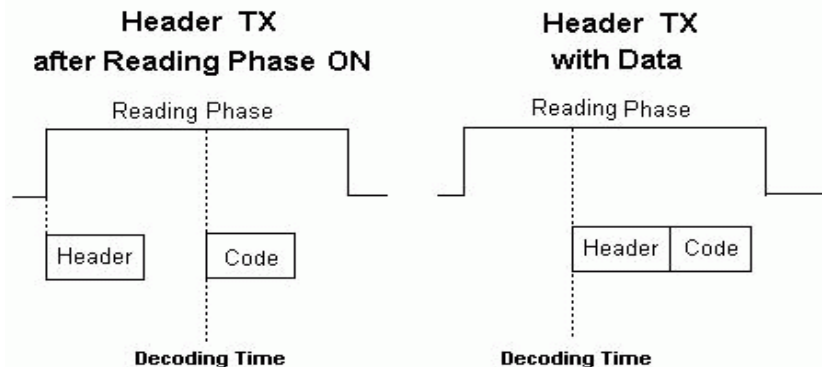

This option is only available when an **Operating Mode of On Line** is selected in **Modify Settings | Global Settings | Operating Mode**.

**Termination After No Read Message**

Select Enable or Disable from the drop-down list. If Enable is selected, a termination string is added to the No Read message string.



This option is only available when an **Operating Mode of On Line** is selected in **Modify Settings | Global Settings | Operating Mode**.

**Select a Message Number to Modify**

Select a numbered message you wish to modify from the drop-down list. the unit has the ability to handle five distinct message structures. Each message may be transmitted out of separate ports.

**Advanced Format: Message Definition n**



The User Socket must be enabled in Ethernet > Sockets to be available here.

**Message Destination**

Select the check box for each port or socket that should receive the message.

**Message Destination Bitmap**

Indicates the destination of the message.

**Message Alignment**

Select None, Left, or Right from the drop-down list.

**Align Length**

Enter the number of characters by which to extend the message when Left or Right is selected from the Message Alignment drop-down box.

### Align Filler Char

Click  to activate the Text Entry Tool and create a filler character in the text field provided. This filler is used to extend the Align Length.

### Header

Click  to activate the Text Entry Tool and create a Header in the text field provided. Headers (up to 128 bytes) can be defined and transmitted as a block preceding the barcode(s). Use characters from NUL (00H) to ~ (7EH).

Click Submit to save your text to the origin window text field, or click Cancel to return to origin window without transferring text.

### Terminator

Click  to activate the Text Entry Tool and create a Terminator in the text field provided. Terminators (up to 128 bytes) can be defined and transmitted as a block following the barcode(s). Use characters from NUL (00H) to ~ (7EH).

Click Submit to save your text to the origin window text field, or click Cancel to return to origin window without transferring text.

### Message Location for Global No Read

Select Only No Read Message, Before No Read Message, or After No Read Message from the drop-down list.

### Global Scale Type (Units)

Select Metric (mm) or Imperial (0.1 in) from the drop-down list. The scale format that will be transmitted.

### Code Identifier

Select Disable, AIM, or Custom from the drop-down list. A Code Identifier string can be included in the output message.

If **Disable** is selected, no code identifier is included in the output message.

If **AIM** is selected, the AIM standard identifier is included in the output message

If **Custom** is selected, the Code Identifier Strings group is activated at the bottom of the window, allowing you to define an identifier string for each code symbology. The string will be included in the output message.

["Messaging | Message Builder" on page 139](#)

### **Code Identifier Strings**

This section of the Message Format window is only available when Custom is

selected as the Code Identifier. Click  to activate the Text Entry Tool and create a custom code identifier string for any listed code symbology.

Click Submit to save your text to the origin window text field, or click Cancel to return to origin window without transferring text.

3. When you have finished making changes, click **Update All** to save all pending changes, click **Reset All** to revert to all previously saved values, and click **Reset Page** to revert to previous saved values on the current page. 0.

# Messaging | Message Builder

Use the **Message Builder** window to configure Standard or Advanced system messages.

**To use the Message Builder:**

1. In the menu under **Modify Settings**, navigate to **Global Settings | Messaging | Message Builder**. The **Message Builder** window opens.

2. Enter the appropriate information in the form as described below:

## **Message Number to Modify**

Select the number of the message you want to modify from the drop-down list.

## **Message n Item List**

### **Idx**

Displays the index number of the messages. This identifies where an item will be located in the host message. This is the information that is placed in the message field. It can range from free flowing text to bar code related information to package related information

### **Type**

Displays the message type including various Text String, Code Related Item, or Package Related Item messages.

### **Qualifier**

Displays relevant qualifiers for the message item if needed. This is the information that is placed in the message field. It can range from free flowing text to bar code related information to package related information.

### **Add**

Click to add a message item to the bottom of the list.



**Add before**

Click to add a message item above the currently selected message.

**Add after**

Click to add a message item below the currently selected message.

**Move up**

Click to move the selected message item up one level in the list.

**Move down**

Click to move the selected message item down one level in the list.

**Remove**

Click to remove the selected message item.

**Item n Definition****Item Type**

Select **Text String**, **Code Related Item**, or **Package Related Item** from the drop-down list. Each selection reveals a unique set of options.

**String Field**

Click  to activate the Text Entry Tool and create a text string message. This option is available when Item Type > Text String has been selected.

Click Submit to save your text to the origin window text field, or click Cancel to return to origin window without transferring text.

**Code Related Items**

Select a code related item from those available in the drop-down list. This option is available when Item Type > Code Related Item has been selected. The Code Related Items can be associated to a specific programmed code or group label depending on the Code Combination selection.

**Barcode:** Barcode data

**Barcode Length:** Number of characters in code

**Read Bitmap:** In tracking mode – 32-bit mask indicating which scanner in the network has read the code (when character <1> is present in the related position). In On Line mode – 32-bit mask indicating the lowest unit number scanner in the network that read the code (when character <1> is present in the related position)

**Total Read Count:** Indicates how many times the code has been read by all scanners present in the network during the same reading phase

**Read Count (by device):** Indicates the number of times the code has been read by one specific scanner present in the network during the reading phase (selectable among those present)

**X Position:** X coordinate for the code that was read

**Y Position:** Y coordinate for the code that was read

**Z Position:** Z coordinate for the code that was read

**Code Identifier:** Indicates type of code that was read



**Code Direction, Code Distance, Decode Mode, Decode Scans Number, Ink Spread, Laser Number, and Reading Persistence are available only when the associated code is read by the Master device.**

**Code Direction:** Indicates if the code has been read either from either the start character or the stop character

**Code Distance:** Indicates the distance from the scan head to the code that was read

**Decode Mode:** Indicates if the reader is configured for Linear or Reconstruction (ACR) reading mode

**Decode Scans Number:** Indicates the minimum number of decoded scans referred to the single characters in a code when the device is reading in

**Average Code Position:** Average position of the code in the scan line (Average of Minimum and Maximum Code Position)

**Minimum Code Position:** Minimum position of the code in the scan line (closest to the left side/connector side of the scanner)

**Maximum Code Position:** Maximum position of the code in the scan line (farthest from the left side/connector side of the scanner)

**Ink Spread:** Indicates the calculated Ink Spread value. This indicates the sharp or blurry quality of the code



**Encoder Value:** Indicates the encoder/tachometer pulse value from trigger to the code being read

**Laser Number:** If more than one laser is present in the working device, this item indicates the laser used to read the code

**Reading Persistence:** Indicates how many times the laser beam has crossed the complete code during the reading phase

### Package Related Items

Select a package related item from those available in the drop-down list. This option is available when Item Type > Package Related Item has been selected.

**Package Sequence Number:** Indicates the sequential number assigned to the package.

**Total Read Bitmap:** Indicates the complete reading mask related to all codes read during the reading phase

**Failure Bitmap:** 32-bit mask indicating which devices in the network are in fault (when character <1> is present in the related position)

**Total Read Count:** Indicates the sum of all Code-related Total Reading Counts of each code read during the reading phase

**Read Count (by device):** Indicates the number of codes read during the reading phase by the device

**Minimum Code Distance:** Indicates the distance of the code closest to the device read during the reading phase

**Maximum Code Distance:** Indicates the distance of the code most distant from the scanner that has been read during the reading phase

**Decode Mode (Master):** Indicates the programmed Reading Mode, either Linear or Reconstruction

**Number of Rejected Codes:** Indicates the number of codes rejected during the internal analysis (unexpected code, multiple read, discarded by the programmed logical rule)

**Package Length:** Indicates the approximate length of the package

**Start Trigger Encoder Value:** Indicates the encoder/tachometer pulse value when the package first hits the trigger PS

**End Trigger Encoder Value:** Indicates the encoder/tachometer pulse value when the package exits the trigger PS

**Transmit Encoder Value:** Indicates the encoder/tachometer pulse value when the data transmit occurs

**Current Trigger Count:** Indicates the number of trigger cycles that have occurred

**Working Hours (By Device):** Indicates the total number of hours the device has been active

**Total Good Reads:** Indicates the total number of barcodes successfully read

**Total No Reads:** Indicates the total number of barcodes that were not read

**Total Multi Reads:** Indicates the number of times packages carried more codes than the scanner is programmed to read

**Total Partial Reads:** Indicates the total number of barcodes only partially read

**Protocol Index/Aux Message:** Indicates the programmed protocol index string data

**Parcel Length:** This is a field received in the Protocol Index from a dimensioner.

**Parcel Width:** This is a field received in the Protocol Index from a dimensioner.

**Parcel Height:** This is a field received in the Protocol Index from a dimensioner.

**Parcel Volume:** This is a field received in the Protocol Index from a dimensioner.

**Parcel Orientation Angle:** This is a field received in the Protocol Index from a dimensioner.

**Isolated Parcel:** This is a field received in the Protocol Index from a dimensioner.

**Cuboidal Parcel:** This is a field received in the Protocol Index from a dimensioner.

**Dimensioner Ready:** This is a field received in the Protocol Index from a dimensioner.

**Dimensioner Legal For Trade:** This is a field received in the Protocol Index from a dimensioner.

**Parcel Box Length:** This is a field received in the Protocol Index from a dimensioner.

**Parcel Box Width:** This is a field received in the Protocol Index from a dimensioner.

**Parcel Box Height:** This is a field received in the Protocol Index from a dimensioner.

**Parcel Corner X1:** This is a field received in the Protocol Index from a dimensioner.  
**Parcel Corner Y1:** This is a field received in the Protocol Index from a dimensioner.  
**Parcel Corner X2:** This is a field received in the Protocol Index from a dimensioner.  
**Parcel Corner Y2:** This is a field received in the Protocol Index from a dimensioner.  
**Parcel Corner X3:** This is a field received in the Protocol Index from a dimensioner.  
**Parcel Corner Y3:** This is a field received in the Protocol Index from a dimensioner.  
**Parcel Corner X4:** This is a field received in the Protocol Index from a dimensioner.  
**Parcel Corner Y4:** This is a field received in the Protocol Index from a dimensioner.  
**Dimensioner Alibi:** This is a field received in the Protocol Index from a dimensioner.  
**Dimensioner Error:** This is a field received in the Protocol Index from a dimensioner.  
**Parcel weight:** This is a field received in the Protocol Index from a scale.  
**Scale Alibi:** This is a field received in the Protocol Index from a scale.  
**Scale Units:** This is a field received in the Protocol Index from a scale.  
**Scale Error:** This is a field received in the Protocol Index from a scale.  
**Scale Legal For Trade:** This is a field received in the Protocol Index from a scale.



**Hour, Minute, Second, Day, Month, and Year can only be entered through the SC5000 Keypad. They are not entered through the GUI.**

**Code/Group Selection**



**Group selection is related to the bar code Groups that are constructed in the Barcode Configuration > Logical Combination. It is only available when Code Related Item > Bar Code, is selected.**

Select a Code/Group from those available in the drop-down list. This option is available when Item Type > Code Related Item has been selected.

**Device Index**

Select a device index number from the drop-down list. This option is available when Item Type > Code Related Item > Read Count (By Device) or Type > Package Related Items > Read Count (By Device)/Working Hours (By Device) has been selected.

**Text String: Options**  
**Link to Code**

Select Disabled, Previous Code, or Next Code from the drop-down list.

- Disabled:** A code will not be linked to this text string
- Previous Code:** The text string will be linked to the previous generated code
- Next Code:** The text string will be linked to the next generated code

**Code Related Item: Options**  
**Code Cutting**

Select None, Simple, or Pattern from the drop-down list.

- Simple:** Allows cutting a programmable part of the code either at the beginning or at the end of the code.

**Pattern:** Allows cutting a part of the code according to a particular prefixed pattern.

**Number of Leading Chars to Cut**

Enter the number of leading characters to cut from the barcode in the field provided (available when Simple is selected from the Code Cutting drop-down list).

**Number of Trailing Chars to Cut**

Enter the number of trailing characters to cut from the barcode in the field provided (available when Simple is selected from the Code Cutting drop-down list).

**Pattern Delimiting Chars to Cut**

Enter the pattern delimiting characters in the field provided (available when Pattern is selected from the Code Cutting drop-down list).

**Pattern Mode**

Select Keep Before, Keep After, or Keep Middle from the drop-down list (available when Pattern is selected from the Code Cutting drop-down list).

**Keep Before:** Cuts the part of the code that starts with the pattern string (data before the string remains).

**Keep After:** Cuts the part of the code that precedes and includes the pattern string (data after the string remains).

**Keep Middle:** Cuts the part of the code before and after (including) the two pattern strings (data between the two strings remains)

Example:

Referring to the window image above, if the read code is SDFR1235689123ASER the transmitted code (depending on the selected Pattern Mode) will be:

Keep Before: SDFR

Keep After: 5689123ASER

Keep Middle: 5689

**Item Alignment**

Select None, Left, or Right from the drop-down list.

**Item Alignment Length**

Enter an Item Alignment Length in the field provided.

**Item Alignment Filler**

Click to activate the Text Entry Tool and create filler text. Click Submit to save your text to the origin window text field, or click Cancel to return to origin window without transferring text.

**Item Data Size**

Select Variable or a number of digits to use from the drop-down list. This is only available when Package Related Item is selected.

**Item Data Format**

Select Decimal (ASCII), Hexadecimal (ASCII), Bitmap (ASCII), or Numeric (Binary) from the drop-down list. This is only available when Package Related Item is selected.

**Package Related Item: Options**  
**Item Alignment**

Select None, Left, or Right from the drop-down list.

**Item Alignment Length**

Enter an Item Alignment Length in the field provided.

**Item Alignment Filler**

Click to activate the Text Entry Tool and create filler text. Click Submit to save your text to the origin window text field, or click Cancel to return to origin window without transferring text.

**Item Data Size**

Select Variable or a number of digits to use from the drop-down list.

**Item Data Format**

Select Decimal (ASCII), Hexadecimal (ASCII), Bitmap (ASCII), or Numeric (Binary) from the drop-down list.

Item Scale Type (Units) Use Global Scale Type, Metric (mm), Imperial (0.1 in.) if package related item is a measure or a weight.

3. When you have finished making changes, click Update All to save all pending changes, click Reset All to revert to all previously saved values, and click Reset Page to revert to previous saved values on the current page.

## Messaging | Statistics

Use the **Statistics** window to select the desired statistical counters, making up the statistics field, and relative statistics field separator string to be sent to the system by the Stand Alone or Master scanner.

To edit the **Statistics** settings:

1. In the menu under **Modify Settings**, navigate to **Global Settings | Messaging | Statistics**. The **Statistics** window opens.

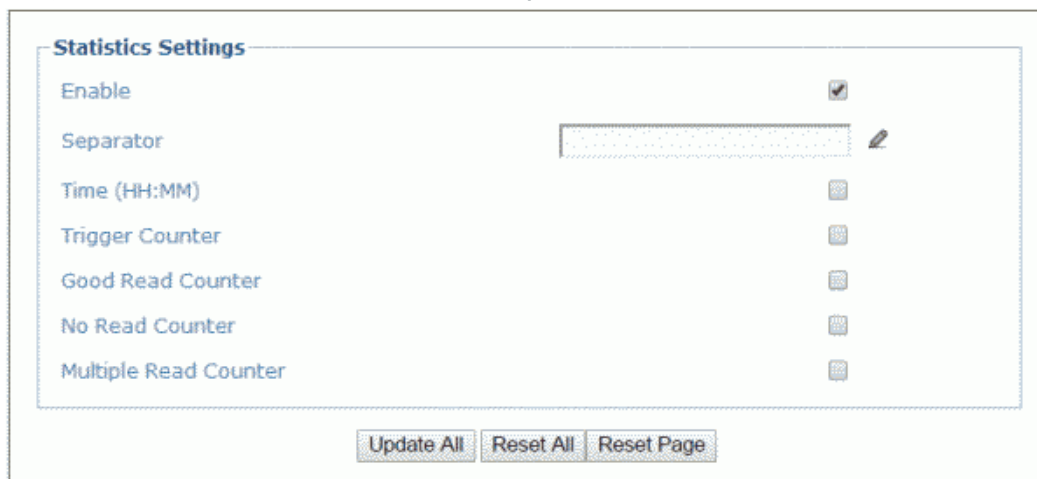

2. Enter the appropriate information in the form as described below:

### Enable

Select the check box to reveal and edit statistic message options. The selections correspond to the message as shown below:

**Barcode Data**

```
14/04/2015 16:20:22> <STX>1234567003..0.50 mm., :-)4 42 96 34 2 0<CR><LF>
```

### Separator

Click to activate the Text Entry Tool and create a Separator in the text field provided. Separator strings (up to 32 bytes) can be created and will be inserted between the last code and the first statistical counter.

Click Submit to save your text to the origin window text field, or click Cancel to return to origin window without transferring text.

**Time (HH:MM)**

Select the check box to include the time counter in the statistical message, reporting the time elapsed in hours and minutes (H MM) from the last hardware reset.

**Trigger Counter**

Select the check box to report the total number of trigger sessions (reading phases) from the last hardware reset.

**Good Read Counter**

Select the check box to report the total number of good reads from the last hardware reset.

**No Read Counter**

Select the check box to report the total number of no reads from the last hardware reset.

**Multiple Read Counter**

Select the check box to report the total number of multiple reads from the last hardware reset.

3. When you have finished making changes, click **Update All** to save all pending changes, click **Reset All** to revert to all previously saved values, and click **Reset Page** to revert to previous saved values on the current page.

## Messaging | Protocol Index

Use the **Protocol Index** window to configure Protocol Index parameters. Protocol Index allows the Host to transmit a string that it has associated to a pack contained within the tracking area.

It is possible to manage several different Protocol Index messages (one per available communication interface), within the same reading phase (for the same package.) If more than one Index message is received on the same communication interface, only the last one will be accepted.

These strings will be received by the SC5000, DX8210 and DS8110 and other devices and included within its output message according to the following order:

1. Built-In Ethernet User Socket 1
2. Built-In Ethernet User Socket 2
3. Built-In Ethernet User Socket 3
4. Auxiliary Serial Port
5. Main Serial Port

**The general output format is:** <Header>Index1 <Data Packet Separator>...IndexN<Data Packet Separator>Standard Message<Terminator>

**The Index field has the following format:** <Index Header>Index Message<Index Terminator>



**This parameter is only available for scanners configured as Standalone or as Master when working in On Line or PackTrack™ operating modes. In OnLine mode, the Protocol Index must arrive during the active reading phase otherwise it will be discarded. If the Distance from Protocol Index to Trigger Line parameter = 0, the Protocol Index must arrive during the active reading phase otherwise it will be discarded. In PackTrack™ mode: If the Distance from Protocol Index to Trigger Line parameter is not=0, the Protocol Index will arrive at the specified distance.**

**To edit the Protocol Index settings:**

1. In the menu under Modify Settings, navigate to **Global Settings | Messaging | Protocol Index**. The **Protocol Index** window opens.

**Protocol Index/Aux Message**

Protocol Index/Aux Message Enable

Receive on Main Serial Port Disable ▾

Receive on Aux Serial Port Disable ▾

Receive on User Socket 1 Enable Without Request ▾

Protocol Index Type Standard ▾

Message Header

Message Terminator

Message Length Variable Length ▾

Message Cutting None ▾

No Index/Message Received Use Repeated Character ▾

No Index/Message - Repeated Character

Receive on User Socket 2 Disable ▾

Receive on User Socket 3 Disable ▾

Receive on User Socket 4 Disable ▾

Receive on User Socket 5 Disable ▾

Receive on User Socket 6 Disable ▾

Receive on Profibus/Profinet Disable ▾

2. Enter the appropriate information in the form as described below:  
**Protocol Index/ Aux Message Enable**

Select the check box to reveal and edit Protocol Index/Aux Message options.

**Receive on Main or Aux Serial Port, or User Socket 1 or 6**

Select Disable, Enable without Request Message, or Enable with Request Message from the drop-down list.

**Disable:** The selected communication channel is not used for Protocol Index string communication.

**Enable without Request Message:** The Host sends the Protocol Index string autonomously on the selected communication channel.

**Enable with Request Message:** The Host waits for the Protocol Index Request Message sent by the scanner, when the trigger detects the presence of a pack, before transmitting the Protocol Index string associated to the pack itself on the selected communication channel.

**Protocol Index Type**

Select Standard, Volume, Scale or Image Name from the drop-down list.

- Standard
- Volume
- Scale
- Image Name
- ASI-ADP / Mux Message (socket only)
- AIM Barcode Messaging

**Request Message**

Click to activate the Text Entry Tool and create a Request Message (up to 128 bytes) to be defined and transmitted. Use characters from NUL (00H) to ~ (7EH). Click Submit to save your changes, or click Cancel to return to previous window.





### Message Header

The data entered in the message header and trailer fields must match the incoming message or the message will not be recognized by the scanner

Click  to activate the Text Entry Tool and create a Header (up to 128 bytes) to be defined and transmitted as a block preceding the Protocol Index string sent by the Host. Use characters from NUL (00H) to ~ (7EH).

Click Submit to save your text to the origin window text field, or click Cancel to return to origin window without transferring text.

### Message Terminator

Click  to activate the Text Entry Tool and create a Terminator to be defined and transmitted as a block following the Protocol Index string sent by the Host. Use characters from NUL (00H) to ~ (7EH).

Click Submit to save your text to the origin window text field, or click Cancel to return to origin window without transferring text.

### Message Length

Select Length in Message, Variable Length, or a length of 3 through 12 from the drop-down list.

Length in Message: The first byte of the scanner output message indicates the length of the Protocol Index string sent by the Host.

Variable Length: The length of the Protocol Index string sent by the Host is variable.

3...12: The Protocol Index string has a fixed length from 3 to 12 characters.

### Message Cutting

Select from the following Message Cutting options:

None  
Simple  
Pattern

### Number of Leading Chars to Cut

Enter the number of leading characters to cut from the barcode in the field provided. (Available when Simple is selected from the Code Cutting options.)

### Number of Trailing Chars to Cut

Enter the number of trailing characters to cut from the barcode in the field provided. (Available when Simple is selected from the Code Cutting options.)

### Pattern Delimiting Chars to Cut

Enter the pattern delimiting characters (available when pattern is selected from the Code Cutting options.)

### Pattern Mode

Select Keep before, keep After, or Keep Middle from the drop-down list (available when pattern is selected from the Code Cutting drop-down list.)

**Keep Before:** Cuts the part of the code that starts with the pattern string (data before the string remains).

**Keep After:** Cuts the part of the code that precedes and includes the pattern string (data after the string remains).

**Keep Middle:** Cuts the part of the code before and after (including) the two pattern strings (data between the two strings remains)

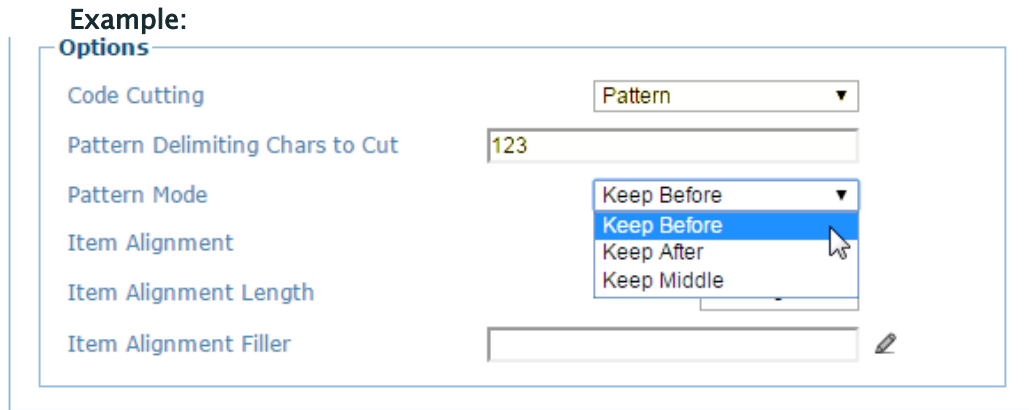

Referring to the window image above, if the read code is SDFR1235689123ASER the transmitted code (depending on the selected Pattern Mode) will be:

**Keep Before:** SDFR

**Keep After:** 5689123ASER

**Keep Middle:** 5689

**No Index/Message Received**

Select one of the following options from the drop-down:

- Use Repeated Character
- Use Specified Message

**No Index/Message – User Message or Repeated Character**

Click  to activate the Text Entry Tool and create a No Index User Message or Repeated Character. Click Submit to save your changes, or Cancel to the previous window.

**Distance from Message Receipt to Trigger**

Enter the distance of travel between when a package hits the trigger (presence sensor) to when it should receive an expected message from, for example, a scale or other device.

When the Receive on Main Serial Port parameter of the selected interface port is set to Enable without Request Message, this parameter specifies the distance from the Trigger Line (i.e. Presence Sensor) to the expected receiving point of the Protocol Index/Aux Message. If set to 0 the Protocol Index/Aux Message must arrive during the active reading phase otherwise it will be discarded.

**Socket Settings**

If ASI ADP/Mux message is selected for Protocol Index Type, the following options are available.

**ASI Device Type**

Select AV6010 or AXIOM/AL5010 from the drop-down

**ASI Device Transmit Edge**

Select Leading or Trailing from the drop-down.

**ASI Device Transmit Point**

Enter the transmit point in inches or mm.

**Receive on Profibus/ Profinet**

Select Disable, Enable with Request, or Enable without Request from the drop-down. This option is only available with the Profibus or Profinet SC5000 unit.

3. When you have finished making changes, click **Update All** to save all pending changes, click **Reset All** to revert to all previously saved values, and click **Reset Page** to revert to previous saved values on the current page.

## Messaging | Pass-Thru

Use the **Pass-Thru** window to pass a message received on ANY port (serial or user socket connection) to any other port(s).

Applications can also be implemented to connect a device such as a hand-held reader to any serial or network port for additional manual code reading capability.

When using Pass-Thru mode, follow these programming notes:

- When using serial ports – Program receiving port same way regarding baud rate, data bits, stop bits and parity to the device sending the data.
- The Termination string must be configured in the same way as the message terminator on the device sending the data. The terminator will be forwarded with the message.

To edit the Pass-Thru settings:

1. In the menu under **Modify Settings**, navigate to **Global Settings | Messaging | Pass-Thru**. The Pass-Thru window opens.

2. Enter the appropriate information in the form as described below:



**The User Socket must be enabled in Ethernet > User Sockets for it to be available in this menu.**

### Source

Select the check box(es) following the Main Serial Port, Aux Serial Port, or numbered User Socket you wish to modify.

### Maximum String Length

Enter the maximum length of the expected string to be received. If the string is longer than the one expected, it will be discarded.

### Termination String

Click  to activate the Text Entry Tool to define the characters terminating the expected string. Click Submit to save your text to the origin window text field, or click Cancel to return to origin window without transferring text.

### Destination

Select the check box next to the destination(s) to be used for the Pass-Thru.

3. When you have finished making changes, click **Update All** to save all pending changes, click **Reset All** to revert to all previously saved values, and click **Reset Page** to revert to previous saved values on the current page. 0.

# Messaging | Diagnostics Messages

Use the **Diagnostic Message** window to select the parameters managing diagnostic message transmission by the **Stand Alone** or **Master** scanner.

To edit the **Diagnostic Message** settings:

1. In the menu under **Modify Settings**, navigate to **Global Settings | Messaging | Diagnostic Message**. The Diagnostic Message window opens.

2. Enter the appropriate information in the form as described below:



**The User Socket must be enabled in Ethernet > User Sockets for it to be available in this menu.**

### Transmit Mode

Select **On Timeout** or **With Code** from the drop-down list. The diagnostic message can be transmitted to the system by the Stand Alone or Master barcode scanner either asynchronously (at programmed intervals), or synchronously with the code.

### Tx Refresh

If Tx Mode is asynchronous (On Timeout) is selected, select a TX Refresh rate in seconds or minutes from the drop-down list to define the time interval in which the diagnostic messages will be transmitted.

### Message Position

If Transmit Mode is synchronous (With Code), the diagnostic messages will be transmitted on the same interface used for code transmission. Select **Append to Code** or **Replace Code** from the drop-down list. This selection determines if the messages will replace the code or be appended to it.

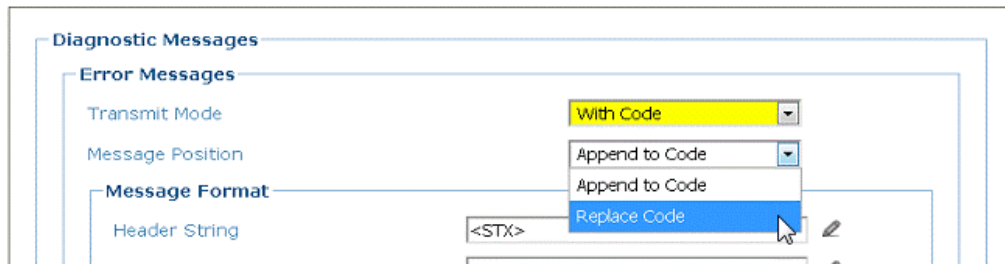

**Message Format**  
**Header String**

Click  to activate the Text Entry Tool to define the header string (up to 128 characters) as a block preceding the diagnostic message. Use characters from NUL (00H) to ~ (7EH).

Click Submit to save your text to the origin window text field, or click Cancel to return to origin window without transferring text.

**Terminator String**

Click  to activate the Text Entry Tool to define the terminator string (up to 128 characters) as a block following the diagnostic message. Use characters from NUL (00H) to ~ (7EH).

Click Submit to save your text to the origin window text field, or click Cancel to return to origin window without transferring text.

**Error Message Type**

Select **Numeric** or **Global String** from the drop-down list to define how the message will be sent.

**Global String (max. 32 chars)**

Click  to activate the Text Entry Tool to define the Global String message (up to 32 bytes) that will be sent as a diagnostic message for any detected diagnostic error.

Click Submit to save your text to the origin window text field, or click Cancel to return to origin window without transferring text.

**Destination**

Select the check box next to the destination(s) to be used for the diagnostic messages. This is only available when the Transmit Mode is set to On Timeout.

**PackTrack/Online Messages**  
**Debug Message Enable**

Select the checkbox to enable debug messages for PackTrack. If selected, this parameter allows transmitting messages concerning the system functioning. This is not available when Operating Mode selection is set to Continuous.

**Debug Message Port**

Select Main Serial, Aux Serial, or Socket n from the drop-down list. The debug message will be transmitted through the selected port.

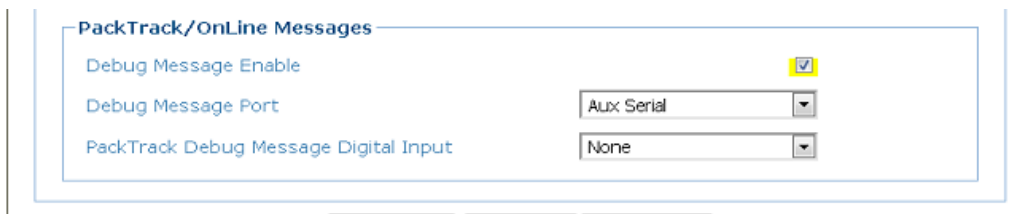

**PackTrack Debug Message Digital Input**

Select **None**, **Trigger (Input 1)**, **Aux (Input 3)**, or **I/O 4 (Input 4)** from the drop-down list. This selection defines which digital input will be used to trigger debug message transmission.

3. When you have finished making changes, click **Update All** to save all pending changes, click **Reset All** to revert to all previously saved values, and click **Reset Page** to revert to previous saved values on the current page.

# Digital I/O

Use the **Digital I/O** window to configure the digital inputs and outputs for your barcode scanning system.

To edit the **Digital I/O** settings:

1. In the menu under **Modify Settings**, navigate to **Global Settings | Digital I/O**. The **Digital I/O** window opens.

**Digital I/O Setting**

**Bidirectional Line Setup**

I/O 4 Direction

**Digital Input Lines**

Trigger (Input 1) Active Level

Aux (Input 3) Active Level

I/O 4 (Input 4) Active Level

**Digital Output Lines**

Select Digital Output Number to View/Modify

**Digital Output 1**

Digital Output 1 Use

Digital Output 1 Line State

**Activation**

Primary Activation Event

Secondary Activation Event

Activate On Error

**Deactivation**

Primary Deactivation Event

Secondary Deactivation Event

Deactivate On Clear Error

Deactivation Timeout  msec

2. Enter the appropriate information in the form as described below:

**Digital Input Lines**  
**Trigger (Input 1) Active Level**

Select Active Closed or Active Open from the drop-down list.

**Active Closed:** Input 1 is active when current flows through (IN1) EXT\_TRIG pins.

**Active Open:** Input 1 is active when there is no current flowing through (IN1) EXT\_TRIG pins.

This parameter setting is not valid, if the input has already been defined in On Line or PackTrack™ [Operating Modes“Operating Mode” on page 54](#).



### Aux (Input 3) Active Level

Select Active Closed or Active Open from the drop-down list.

**Active Closed:** Input 3 is active when current flows through IN3 pins.

**Active Open:** Input 3 is active when there is no current flowing through IN3 pins.



This parameter setting is not valid, if the input has already been defined in On Line or PackTrack™ Operating Modes "Operating Mode" on page 54.

### I/O (Input 4) Active Level

Select Active Closed or Active Open from the drop-down list.

**Active Closed:** Input 4 is active when current flows through IN3 pins.

**Active Open:** Input 4 is active when there is no current flowing through IN3 pins.



This parameter setting is not valid, if the input has already been defined in On Line or PackTrack™ Operating Modes. See "Operating Mode" on page 54.

### Digital Output Lines

#### Select Digital Output Number to View/Modify.

Select the number of the output you will view or modify from the drop-down list.

### Digital Output n

#### Digital Output n Use

Select Local, EthernetIP, Profibus/Profinet, or Redundancy from the drop-down list. This parameter selects the source that drives the digital output. Local output is driven by the device application program. EthernetIP is driven by the EtherNet/IP Host and Profibus/Profinet is driven by the relative Fieldbus Host.

### Digital Output n Line State

Select Normally Open or Normally Closed from the drop-down list.

Each output can be represented with an NPN transistor; this transistor acts like a switch: so, when the transistor is OFF, it acts like an OPEN switch. On the contrary, when the transistor is ON, it acts like a CLOSED switch.

**Normally Open:** The idle state of the output line is open, that is, the NPN transistor is OFF (like an open switch). When the output is activated, the transistor goes ON (like a closed switch).

**Normally Closed:** The idle state of the output line is closed, that is, the NPN transistor is ON (like a closed switch). When the output is activated, the transistor goes OFF (like an open switch).

### Activation

#### Primary Activation Event And Secondary Activation Event

Select a Primary Activation Event from the drop-down list.

**None:** The output is always in line state.

**Complete Read:** The event occurs, if all selected codes are read.

**Partial Read:** The event occurs, if less than the selected codes are read.

**No Read:** The event occurs, if no code is read.

**Trigger On:** The event occurs, when a start event takes place starting the reading phase.

**Trigger Off:** The event occurs, when a stop event takes place ending the reading phase.

**Multiple Read:** The event occurs, if a code is read more than once consecutively.

**Right/Match:** The event occurs, if a code is successfully decoded and matches the [Match Code](#) (Verifier Code).

**Wrong/No Match:** The event occurs, if a code is successfully decoded but does not match the [Match Code](#) (Verifier Code).

### Activate On Error

When using this parameter, all other activation events should be set to None.



Select Disable or Enable from the drop-down list. If this parameter is enabled, the output will activate when a diagnostic error message is sent.

### Deactivation

#### Primary Deactivation Event

Select a Primary Deactivation Event from the drop-down list.

**None:** A deactivation event is NOT defined.

**Timeout:** Indicates the maximum duration of the output pulse. When selected, the Deactivation Timeout text field is revealed.

**Trigger On:** The event occurs, when a start event takes place starting the reading phase.

**Trigger Off:** The event occurs, when a stop event takes place terminating the reading phase.

#### **Secondary Deactivation Event**

Select a Secondary (Alternate) Deactivation Event from the drop-down list (see below).

**None:** A secondary deactivation event is NOT defined.

**Trigger On:** The event occurs, when a start event takes place starting the reading phase.

**Trigger Off:** The event occurs, when a stop event takes place terminating the reading phase.

#### **Deactivate On Clear Error**

Select Disable or Enable from the drop-down list. If this parameter is enabled, the output will deactivate when the error is no longer present.

#### **Deactivation Timeout**

Enter the maximum duration of the output pulse in the text field provided. Input a value from 40 to 15000 milliseconds.

3. When you have finished making changes, click **Update All** to save all pending changes, click **Reset All** to revert to all previously saved values, and click **Reset Page** to revert to previous saved values on the current page.

## Diagnostics

Use the **Diagnostics** window to configure error reporting for your barcode scanning system.

To edit the Diagnostics settings:

1. In the menu under **Modify Settings**, navigate to **Global Settings | Diagnostics**. The Diagnostics window opens.



This window will look different based upon the Operating Mode Selection in Operating Mode settings. The example below is for Online Mode.

2. Enter the appropriate information in the form as described below:

### Sampling Time

Select a Sampling Time in seconds or minutes from the drop-down list. This selection indicates the time lapse between system diagnostic queries.

### Report Slave Scanner Diagnostics

Select the check box to report diagnostic information from the slave scanners in the system.

### Display Warnings as Alarms

Select the check box to report warnings as alarms.

### Errors To Report

Select the check box next to each error type the system should report.

**No Scan Signal Failure**  
**APD Sensor Failure**  
**Motor Failure**  
**SD Card Failure**  
**In-the-Beam Sensor Failure**  
**Laser Failure**  
**Motor Warning**

**Online Mode**

**Diagnostic Settings**

Sampling Time  ▾

Report Slave Scanner Diagnostics

Display Warnings as Alarms

**Errors To Report**

No Scan Signal Failure	<input checked="" type="checkbox"/>	In-the-beam Sensor Failure	<input checked="" type="checkbox"/>
APD Sensor Failure	<input checked="" type="checkbox"/>	Laser Failure	<input checked="" type="checkbox"/>
Motor Failure	<input checked="" type="checkbox"/>	Motor Warning	<input checked="" type="checkbox"/>
SD Card Failure	<input checked="" type="checkbox"/>		

Presence Sensor Stuck Timeout  ▾

No Phase Timeout  ▾

Protocol Index Alarms

Maximum Consecutive Lost Protocol Indexes

Maximum % Of Lost Protocol Indexes  %

**Presence Sensor Stuck Timeout**

Select Disable or a time interval in seconds or minutes from the drop-down list. If a time interval is selected, a stuck sensor will report an error after the selected interval.

**No Phase Timeout**

Select Disable or a time interval in seconds or minutes from the drop-down list. If a time interval is selected, a stuck sensor will report an error after the selected interval.

**Continuous Mode**

**Diagnostic Settings**

Sampling Time  ▾

Report Slave Scanner Diagnostics

Display Warnings as Alarms

**Errors To Report**

No Scan Signal Failure	<input checked="" type="checkbox"/>	In-the-beam Sensor Failure	<input checked="" type="checkbox"/>
APD Sensor Failure	<input checked="" type="checkbox"/>	Laser Failure	<input checked="" type="checkbox"/>
Motor Failure	<input checked="" type="checkbox"/>	Motor Warning	<input checked="" type="checkbox"/>
SD Card Failure	<input checked="" type="checkbox"/>		

Encoder Failure

Encoder Timeout  ▾

Protocol Index Alarms

Maximum Consecutive Lost Protocol Indexes

Maximum % Of Lost Protocol Indexes  %

**Encode Failure**

Click the check box to report encoder errors.

**Encoder Timeout**

Select disable or a time interval in seconds or minutes from the drop-down list. If a time interval is selected, a stuck encoder will report an error after the selected interval.

**PackTrack Mode**

**Diagnostic Settings**

Sampling Time: 2 sec

Report Slave Scanner Diagnostics:

Display Warnings as Alarms:

**Errors To Report**

No Scan Signal Failure	<input checked="" type="checkbox"/>	In-the-beam Sensor Failure	<input checked="" type="checkbox"/>
APD Sensor Failure	<input checked="" type="checkbox"/>	Laser Failure	<input checked="" type="checkbox"/>
Motor Failure	<input checked="" type="checkbox"/>	Motor Warning	<input checked="" type="checkbox"/>
SD Card Failure	<input checked="" type="checkbox"/>		

PTP Time Synchronization Failure:

Encoder Failure:

Encoder Timeout: Disable

Presence Sensor Failure:

No Phase Timeout: Disable

Protocol Index Alarms:

Maximum Consecutive Lost Protocol Indexes: 3

Maximum % Of Lost Protocol Indexes: 5 %

Update All   Reset All   Reset Page

**PTP Time Synchronization Failure**

Click the check box to report PTP (Precision Time Protocol) Time Synchronization errors.

**Encode Failure**

Click the check box to report encoder errors.

**Encoder Timeout**

Select disable or a time interval in seconds or minutes from the drop-down list. If a time interval is selected, a stuck encoder will report an error after the selected interval.

**Presence Sensor Failure**

Click the check box to enable presence sensor failure.

**No Phase Timeout**

Select Disable or a time interval in seconds or minutes from the drop-down list. If a time interval is selected, a stuck sensor will report an error after the selected interval.

3. When you have finished making changes, click **Update All** to save all pending changes, click **Reset All** to revert to all previously saved values, and click **Reset Page** to revert to previous saved values on the current page.

## Energy Saving

Use Energy Saving window to activate/deactivate energy saving features. In particular, it allows turning network scanner motors and lasers on or off according to specific conditions. Use this parameter when the conveyor is stopped for a long period of time.

To view and edit Energy Saving settings:

1. In the menu under Modify Settings, navigate to Global Settings | Energy Saving. Energy Saving window opens.

2. Enter the appropriate information in the form as described below:

### Energy Saving Configuration

Select the check box to reveal Energy Saving Configuration options.

#### Use Encoder For

Select None, Deactivation, Activation, or Activation and Deactivation from the drop-down list. This parameter allows defining the function to be performed by an Encoder:

**None:** No function is performed by the digital input.

**Deactivation:** The digital input is used to deactivate Energy Saving. Thus, the motor and laser of all network scanners will be turned on.

**Activation:** The digital input is used to activate Energy Saving. Thus, the motor and laser of all network scanners will be turned off.

**Activation and Deactivation:** The digital input is used to both activate and deactivate Energy Saving. Thus, the motor and laser of all network scanners will be turned on/off.

#### Activation Encoder Timeout

Select a minute value from the drop-down list. This parameter is available only when the encoder is used for Energy Saving activation. If the encoder is stopped for

more than the programmed timeout, Energy Saving will be activated.

#### **Deactivation Encoder Timeout**

Select a second or minute value from the drop-down list. This parameter is available only when the encoder is used for Energy Saving deactivation. If the encoder runs for at least the programmed timeout, Energy Saving will be deactivated.

#### **Use Digital Input For**

Select None, Deactivation, Activation, or Activation and Deactivation from the drop-down list. This parameter allows defining the function to be performed by a digital input:

**None:** No function is performed by the digital input.

**Deactivation:** The digital input is used to deactivate Energy Saving. Thus, the motor and laser of all network scanners will be turned on.

**Activation:** The digital input is used to activate Energy Saving. Thus, the motor and laser of all network scanners will be turned off.

**Activation and Deactivation:** The digital input is used to both activate and deactivate Energy Saving. Thus, the motor and laser of all network scanners will be turned on/off.

#### **Select Digital Input**

Select a digital input from the drop-down list. This parameter defines the digital input to be used for activating/deactivating Energy Saving.

#### **Select Input Type**

Select Edge or Level from the drop-down list.

#### **Use Main Serial Port For**

Select None, Deactivation, Activation, or Activation and Deactivation from the drop-down list. This parameter allows defining the function to be performed by Main Serial Port:

**None:** No function is performed by the digital input.

**Deactivation:** The digital input is used to deactivate Energy Saving. Thus, the motor and laser of all network scanners will be turned on.

**Activation:** The digital input is used to activate Energy Saving. Thus, the motor and laser of all network scanners will be turned off.

**Activation and Deactivation:** The digital input is used to both activate and deactivate Energy Saving. Thus, the motor and laser of all network scanners will be turned on/off

#### **Header**



**This parameter is available only when a communication channel has been selected to perform a specific function.**

Click  to activate the Text Entry Tool and create a Header (up to 128 bytes) to define a header (1 byte) and transmit it as a block preceding the activation/deactivation string sent to a Master or Stand Alone scanner. Use characters from NUL (00H) to ~ (7EH). Click Submit to save your text to the origin window text field, or click Cancel to return to origin window without transferring text.

#### **Terminator**



**This parameter is available only when a communication channel has been selected to perform a specific function.**

Click  to activate the Text Entry Tool and create a Terminator to define a terminator (1 byte) and transmit it as a block following the activation/deactivation string sent to the Master or Stand Alone scanner. Use characters from NUL (00H) to ~ (7EH). Click Submit to save your text to the origin window text field, or click Cancel to return to origin window without transferring text.

#### **Activation String**



**This parameter is available only when a communication channel has been selected to perform a specific function.**

Click  to activate the Text Entry Tool and create a string that defines the characters to be transmitted within the output message to activate Energy Saving.



Click Submit to save your text to the origin window text field, or click Cancel to return to origin window without transferring text.

### Deactivation String



**This parameter is available only when a communication channel has been selected to perform the Deactivation or Activation & Deactivation function.**

Click  to activate the Text Entry Tool and create a character string to be transmitted within the output message to deactivate Energy Saving. Click Submit to save your text to the origin window text field, or click Cancel to return to origin window without transferring text.

### Use Aux Serial Port For

Select None, Deactivation, Activation, or Activation and Deactivation from the drop-down list. This parameter allows defining the function to be performed by the Aux Serial Port:

**None:** No function is performed by the digital input.

**Deactivation:** The digital input is used to deactivate Energy Saving. Thus, the motor and laser of all network scanners will be turned on.

**Activation:** The digital input is used to activate Energy Saving. Thus, the motor and laser of all network scanners will be turned off.

**Activation and Deactivation:** The digital input is used to both activate and deactivate Energy Saving. Thus, the motor and laser of all network scanners will be turned on/off.

### Header



**This parameter is available only when a communication channel has been selected to perform a specific function.**

Click  to activate the Text Entry Tool and create a Header (up to 128 bytes) to define a header (1 byte) and transmit it as a block preceding the activation/deactivation string sent to a Master or Stand Alone scanner. Use characters from NUL (00H) to ~ (7EH). Click Submit to save your text to the origin window text field, or click Cancel to return to origin window without transferring text.

### Terminator



**This parameter is available only when a communication channel has been selected to perform a specific function.**

Click  to activate the Text Entry Tool and create a Terminator to define a terminator (1 byte) and transmit it as a block following the activation/deactivation string sent to the Master or Stand Alone scanner. Use characters from NUL (00H) to ~ (7EH). Click Submit to save your text to the origin window text field, or click Cancel to return to origin window without transferring text.

### Activation String



**This parameter is available only when a communication channel has been selected to perform the Deactivation or Activation & Deactivation function.**

Click  to activate the Text Entry Tool and create a string that defines the characters to be transmitted within the output message to activate Energy Saving. Click Submit to save your text to the origin window text field, or click Cancel to return to origin window without transferring text.

### Deactivation String



**This parameter is available only when a communication channel has been selected to perform the Deactivation or Activation & Deactivation function.**

Click  to activate the Text Entry Tool and create a character string to be transmitted within the output message to deactivate Energy Saving. Click Submit to save your text to the origin window text field, or click Cancel to return to origin window without transferring text.

### User Socket n For

Select None, Deactivation, Activation, or Activation and Deactivation from the drop-down list. This parameter allows defining the function to be performed by a numbered Socket:

**None:** No function is performed by the digital input.

**Deactivation:** The digital input is used to deactivate Energy Saving. Thus, the motor and laser of all network scanners will be turned on.

**Activation:** The digital input is used to activate Energy Saving. Thus, the motor and laser of all network scanners will be turned off.

**Activation and Deactivation:** The digital input is used to both activate and deactivate Energy Saving. Thus, the motor and laser of all network scanners will be turned on/off.

### Header



This parameter is available only when a communication channel has been selected to perform a specific function.

Click  to activate the Text Entry Tool and create a Header (up to 128 bytes) to define a header (1 byte) and transmit it as a block preceding the activation/deactivation string sent to a Master or Stand Alone scanner. Use characters from NUL (00H) to ~ (7EH). Click Submit to save your text to the origin window text field, or click Cancel to return to origin window without transferring text.

### Terminator



This parameter is available only when a communication channel has been selected to perform a specific function.

Click  to activate the Text Entry Tool and create a Terminator to define a terminator (1 byte) and transmit it as a block following the activation/deactivation string sent to the Master or Stand Alone scanner. Use characters from NUL (00H) to ~ (7EH). Click Submit to save your text to the origin window text field, or click Cancel to return to origin window without transferring text.

### Activation String



This parameter is available only when a communication channel has been selected to perform a specific function.

Click  to activate the Text Entry Tool and create a string that defines the characters to be transmitted within the output message to activate Energy Saving. Click Submit to save your text to the origin window text field, or click Cancel to return to origin window without transferring text.

### Deactivation String



This parameter is available only when a communication channel has been selected to perform the Deactivation or Activation & Deactivation function.

Click  to activate the Text Entry Tool and create a character string to be transmitted within the output message to deactivate Energy Saving. Click Submit to save your text to the origin window text field, or click Cancel to return to origin window without transferring text.

- When you have finished making changes, click **Update All** to save all pending changes, click **Reset All** to revert to all previously saved values, and click **Reset Page** to revert to previous saved values on the current page. 0.

## HMI Settings

Use the **HMI Settings** window to configure some aspects of the scanner LEDs and X-Press™ interface.

To view and edit the HMI Settings:

1. In the menu under **Modify Settings**, navigate to **Global Settings | HMI Settings**. The HMI Settings window opens.

2. Enter the appropriate information in the form as described below:

### **Display Settings**

#### User Interface Type

Select Standard or US Aiport from the drop-down list.

#### 'Last Code Read' Display

Select Disable, Statistics (Last 100 Codes), or Statistics from the drop-down list.

#### Enable Last 10 Codes Display

Select the check box to display the last ten barcodes read.

### **Web Interface Settings**

#### Password

Default Password is DLA,

#### Password (repeat)

Enter a password required to access the Web Interface

3. When you have finished making changes, click **Update All** to save all pending changes, click **Reset All** to revert to all previously saved values, and click **Reset Page** to revert to previous saved values on the current page.

## Device Settings

Use the Device Settings Menu Tree selections during initial mounting and setup to view device information and configure your system devices. If multiple scanners are used in a tunnel or array, each named scanner will be listed under Device Settings with the sub-menus **Device Info**, **Mounting**, and **Options**. If necessary, you can later make modifications to the configuration using the same menu selections, including:

Device Settings

Name Scanner

[“Device Settings | Device Info” on page 169](#)

[“Device Settings | Mounting” on page 171](#)

[“Device Settings | Options” on page 173](#)

## Device Settings | Device Info

Use the **Device Info** window to view information about each device in the system including description, serial number and address. The information on this page is not editable.

To view the **Device Info** window:

1. In the menu under **Modify Settings**, navigate to **Device Settings | Device Name (if applicable) | Device Info**. The **Device Info** window opens.

Device Information	
Description	Controller
Device Address	0
Serial Number	SC5000X01
MAC Address	000E1304D100
Model Name	SC5000-1100
Model Number	101
Hardware Release	2
Number Legs	0
Number Lasers	0
Number Facets	0
Scan Rate (scans/sec)	1000
Software Versions	
Software Version	ARM_release_v0_9_5_4
DSP Version	Decoder_release_v1_8_18_0
FPGA Version	XLC_v20_5_0_0

2. View the following scanner information.

### Description

Displays the scanner description entered in the [System Info](#) window.

### Device Address

Displays the system address which is generated from the Dev information found on the System Information page.

### Serial Number

Displays the serial number sent by the device.

### MAC Address

Displays the MAC (media access control) address of the device.

### Model Name

Displays the Model name sent by the device.

### Model Number

Displays the Model number sent by the device.

### Hardware Release

Displays the hardware release number of the device.

### Number Legs

Displays the number of laser legs (beams) produced by the device. Each DS8110 (Line) scanner has 1 leg, while each DX8210 (X) scanner has 2 legs.

### Number Lasers

Displays the number of lasers used by the scanner.

### Number Facets

Displays the number of facets in the mirror wheel.

**Scan Rate (scans/sec)**

Displays the scans/per second achieved by the scanner.

**Software Versions**

**Software Version**

Displays the currently installed version of the ARM (anonymizing relay monitor) software.

**DSP Version**

Displays the currently installed version of the decoder software.

**FPGA Version**

Displays the currently installed version of the field-programmable gate array software.

## Device Settings | Mounting

Use the **Mounting** window to calibrate your scanner.

To view and edit the **Mounting** settings:

1. In the menu under **Modify Settings**, navigate to **Device Settings | Device Name (if applicable) | Mounting**. The Mounting window opens.



If more than one device is included in the scanning system, the device name will be listed in the menu tree after the Device Settings level.

2. Enter the appropriate information in the form as described below:

### Calibration Method

Select Use Built-In Calibration or **PackTrack Calibration** from the drop-down list. Use Built-In Calibration only available for the DX8210, and you must manually enter the requested data. If PackTrack Calibration is selected, use the wizard to automatically enter most of the data.

Both the Built-In and PackTrack Calibration methods need manually entered data. The Built-In method reduces the number of entries for the scanner to calculate the PackTrack parameters.

### PackTrack Calibration PackTrack Calibration Wizard

Click Launch Wizard to open the PackTrack™ Calibration Wizard. View PackTrack calibration in the On line help for the particular scanner.

### Calibration Adjustment Y Adjustment

Enter the scanner adjustment from Y axis in millimeters in the field provided. This is used to make fine adjustments to the tested calibration. This is used during dynamic calibration to fine tune the Y parameter.

For complete instructions on setting up your scanners using PackTrack, see the DX8210 and DS8110 Reference Manuals, available at [www.datalogic.com](http://www.datalogic.com).

### **PackTrack Calibration Coefficients** **Calibration Item**

1–9

These non-editable fields display the PackTrack calculations.

3. When you have finished making changes, click **Update All** to save all pending changes, click **Reset All** to revert to all previously saved values, and click **Reset Page** to revert to previous saved values on the current page.

### **PackTrack™ Calibration Wizard**

**PackTrack™** is a patented operating mode for **Datalogic Omni-Directional Reading Stations** used to read and correctly assign codes read on different packs when placed in the scanner Reading Area at the same time.

For complete instructions on setting up your scanners using **PackTrack**, see *the DX8210 and DS8110 Reference Manuals*, available at [www.datalogic.com](http://www.datalogic.com).



## Device Settings | Options

Use the **Options** window to configure the scanner LEDs and X-Press Interface. To view the Options settings:

1. In the menu under **Modify Settings**, navigate to **Device Settings | Device Name (if applicable) | Options**. The Options window opens.



If more than one device is included in the scanning system, the device name will be listed in the menu tree after the Device Settings level.

Options will vary depending on which device is being represented.

2. Enter the appropriate information in the form as described below:  
**Field of View Start Angle (DS8110)**

Enter the field of view (FOV) start angle in the field provided. This will adjust the start FOV angle to that specified.

In the example below, the original Start Angle of 30° is reduced to 25° degrees when that value is entered.

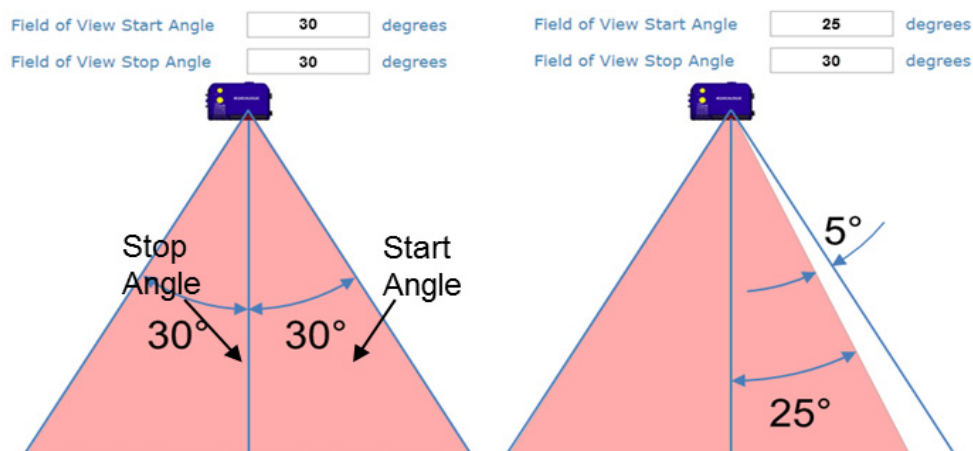

This option is only available for the DS8110 scanner.

### Field of View Stop Angle (DS8110)

Enter the field of view (FOV) stop angle in the field provided. This will adjust the start FOV angle to that specified.



**This option is only available for the DS8110 scanner.**

### Barcode Reconstruction

Select the check box to enable Advanced Code Reconstruction (ACR™ 4) when reading the code. If not checked, standard linear reading mode will be used. [Enable Stacked Codes](#)



**This item may increase data processing time. The delay may affect the scanners ability to provide a good read in time for data transmission.**

Select the check box to improve code reconstruction when two or more codes (of the same or different symbologies) are stacked one on top of the other with little or no space between them.

### Configure ETH-2 for Dedicated Setup/Aux

In a master/slave system (scanner as master, not an SC5000), this option is available for slave scanners. Select the check box to enable.

This option applies to the last slave scanner in the daisy-chain system, allowing the open Ethernet port to work as a dedicated setup port.

In practice, you can always communicate using this port, but selecting the checkbox turns off all of the other EBC traffic on that port.

WARNING



**This option must only be applied to the last slave scanner in the EBC network. Applying this option to the other slaves will disrupt the EBC network.**

WARNING



### **Advanced Reading Settings**

**Advanced Reading Settings are intended for special cases only, and must only be applied with the guidance of Datalogic Support.**

### Use Advanced Analysis (ACRS)

Select the checkbox to enable advanced decoding options that may help some applications. However, they can cause increased processing time.

### Overflow Start Ratio

Enter the minimum expected width of the barcode starting quiet zone, expressed in number of modules from 1 to 50.

### Overflow Stop Ratio

Enter the minimum expected width of the barcode stopping quiet zone, expressed in number of modules from 1 to 50.



**Use the DS8110 and DX8210 Digitizer Settings to increase scan element throughput and provide support for a white belt and wooden box filter.**

## Digitizer Settings

Digitizer Settings	
White Belt Filter	Enabled <input type="button" value="v"/>
White Belt Filter Threshold	<input type="text" value="96"/>
White Belt Filter Range	<input type="text" value="1321"/> mm
Wooden Box Filter	Enabled <input type="button" value="v"/>
Number of FPGA Registers to Patch	None <input type="button" value="v"/>

WARNING



Field-Programmable Gate Array (FPGA) patches are intended for special cases only, and must only be applied with the guidance of Datalogic Support.

### White Belt Filter

Select Enabled or Disabled from the drop-down. Enables filtering to reduce background noise when reading over a white conveyor belt.

### White Belt Filter Threshold

When White Belt Filter is enabled, you need to enter a filter threshold.

### White Belt Filter Range

When White Belt Filter is enabled, you need to enter a filter range.

### Wooden Box Filter

Select Enabled or Disabled from the drop-down. Enables filtering to reduce background noise when codes are on a wood grained surface.

### Number of FPGA Registers to Patch

Select a number from the drop-down list.

### FPGA Register n Offset

Enter the register offset in the field provided.

### FPGA Register n Value

Enter the register value in the field provided.

### FPGA Register n Side to Patch

Select A+B Side, A Side, or B Side from the drop-down list. "Side" refers to the laser leg of the DX8210, and allow you to choose both legs or either one.

- When you have finished making changes, click **Update All** to save all pending changes, click **Reset All** to revert to all previously saved values, and click **Reset Page** to revert to previous saved values on the current page.

## Diagnostics

Use the Diagnostics menu tree selections to monitor your barcode scanning system performance, view system messages, and access online help. The Diagnostic windows include:

[“Diagnostics | Monitor” on page 177](#)

[“Diagnostics | Read Test” on page 179](#)

[“Diagnostics | Status Viewer” on page 180](#)

## Diagnostics | Monitor

Use the Diagnostics > Monitor as the primary tool to monitor the reader's operation and bar code readability in real-time. Status indicators and vital statistics appear on a single screen, enabling you to effectively and efficiently detect and troubleshoot any problems that may occur.

### To open the Monitor window:

In the menu under **Diagnostics**, navigate to **Monitor**. The **Monitor** window opens.

The status indicators in **Diagnostics > Monitor** indicate the following conditions:

### Status

#### Phase/Trigger

**GREEN** indicates trigger input. The LED is activated upon trigger input regardless of trigger source (including software trigger).

#### Good/No Read

**GREEN** indicates a good (valid) bar code has been decoded.

**RED** indicates a no-read (or incomplete decode).

#### Multiple

**RED** indicates more codes than desired were read.

#### Partial

**RED** indicates a partial read.

#### Output 1 – 4

**RED** indicates activity on that output.

#### Belt Speed

Indicates the current speed of the belt indicated by the encoder (tachometer) or internal tachometer.

### Barcode Information

#### Code Distance (cm)

Displays the distance from the laser origin to the scanned barcode.

#### Scan Position

Displays the position of the code in the scan line.

**Near**

**GREEN** indicates the barcode has been scanned by the near-focus laser.

**Far**

**GREEN** indicates the barcode has been scanned by the far-focus laser.

**Messages**

**Message Field**

Displays message data being returned by the scanner for each barcode scanned.

**Read Rate**

**Package Count**

Displays the number of packages detected since the last reset.

**Good Read (%)**

Displays the number of good barcode reads since the last reset.

**Multiple (%)**

Displays the number of multiple barcodes detected since the last reset.

**Partial (%)**

Displays the number of partially read barcodes since the last reset.

**No Read (%)**

Displays the number of no reads (no barcode read on package) since the last reset.

**Reset**

Click to reset the above counters.

**Message Monitor**

**Message Monitor Field**

Select the option button beside Main, Aux, Socket 1, Socket 2, Socket 3, Socket 4, Socket 5, Socket 6, or Fieldbus to display messages for that host port.

Select the option button beside None to stop displaying messages.

**Connect/ Disconnect**

Click Disconnect to stop (freeze) the Monitor window, or click Connect to start the Monitor window.

## Diagnostics | Read Test

Use the Read Test window to check how well a scanner is operating.

To test a scanner's operation:

1. In the menu under **Diagnostics**, navigate to **Read Test**. The **Read Test** window opens.

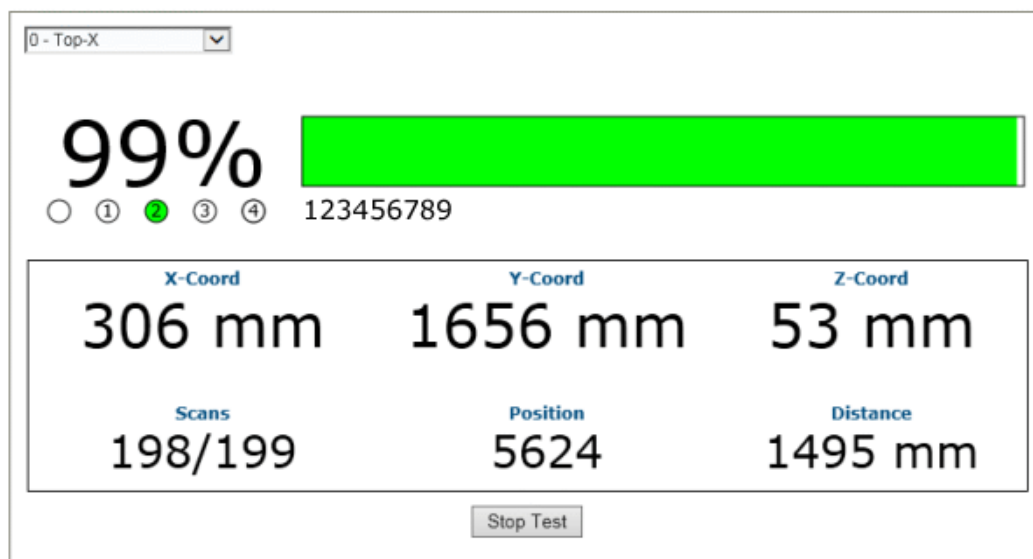

2. If there are multiple scanners in the system, select the scanner to test from the drop-down list at the top of the **Read Test** window.
3. Click the **Start/Stop Test** toggle button to run or stop the real-time performance display of the scanner.

**The Read Test displays the following information:**

- **Read Rate:** This is the percentage readout and bar at the top of the window, displaying the read rate since the start of the test.
- The numbered circle indicators below the read-rate percentage indicate in **GREEN**, which of the scanner's lasers is reading the barcode.
- The alpha numeric text following the numbered circle indicators is the barcode data.
- **Laser Identifiers:** These circles below the Read Rate percentage identify the number of lasers in the scan head as well as highlighting in **GREEN** the laser that is reading the barcode. In the example above, the scanner has four lasers and laser 2 is identified as reading the code. If the first circle is highlighted in **RED**, this indicates a **NOREAD**.
- **XYZ Coord:** This displays the real-time coordinates of the barcodes being read.
  - X = the distance across the conveyor
  - y = the distance from the trigger photo sensor
  - Z = distance from the conveyor surface for a top read and the distance from the far rail for a side read
- **Scans:** Displays the number of times the scanner decoded the test barcode out of the number of opportunities it had to decode the test barcode during a test cycle.
- **Position:** Displays the position of the barcode in the scan line.
- **Distance:** Displays the distance from the laser origin to the last barcode read.

## Diagnostics | Status Viewer

Use the **Status Viewer** to check up on your scanner health.

To access and use the **Status Viewer**:

1. In the menu under Diagnostics, navigate to Status Viewer. The Status Viewer window opens.

The screenshot shows the Status Viewer interface for a device named '1 - Drum'. At the top left, there is a dropdown menu showing '1 - Drum'. The main content area displays the following information:

```

SYSTEM WARNING AND ERROR CODES
Warning Codes: None
Error Codes:  None

HARDWARE STATUS
Motor:        No Errors or Warnings
Lasers:       No Errors or Warnings
Acquisition: No Errors or Warnings

Powered On Time: 11-20:53:29.049

Total Power On Time: 168 years  18 days  6 hours
Total Operating Time: 66 years  326 days  21 hours
  
```

At the bottom of the main content area, there are five buttons: **Status**, **H/W Info**, **Counters**, **Message Log**, and **Clear**.

Below the main content area, there is a section labeled **Command** with a text input field and a **Send Command** button. Below the input field, it says "Use this field to enter and send commands".

2. Select a device to view from the drop-down list at the top-left corner of the window.
3. Click on a button at the bottom of the display window to select the type of information you want to view:
  - **Status:** displays system warnings or errors.

This is a close-up screenshot of the Status Viewer window, showing the same information as the previous screenshot but with a different powered-on time:

```

SYSTEM WARNING AND ERROR CODES
Warning Codes: None
Error Codes:  None

HARDWARE STATUS
Motor:        No Errors or Warnings
Lasers:       No Errors or Warnings
Acquisition: No Errors or Warnings

Powered On Time: 1-01:33:41.237

Total Power On Time:  0 years  294 days  20 hours
Total Operating Time:  0 years  283 days  22 hours
  
```



- **Read Rate:** displays read rate and package count information.

```

READ RATE
Total Packages:      34204
Good Reads:         25086      73%
No Reads:           837        2%
Partial:            8281      24%
Multiple:            0         0%

```

- **H/W Info:** displays information about the selected hardware, including model, serial number, scans/second, laser information, and more.

```

CONFIGURATION
Model Type:  DS8110-2100
Serial Num:  C14C03507
Mac Address: 00-07-be-00-ef-8a
Num Lasers:  2
Num Legs:    1
Num Facets:  7

CURRENT STATUS
Scan Rate:    1000 scans/sec
Current APD DAC: 469

                Temp      VCC
Laser 1:      40.59 C    3.2790
Laser 2:      40.89 C    3.2722
Logic Board:  39.00 C
APD Board:    41.50 C

```

- **Counters:** displays cumulative data about scans, triggers, errors, and much more.

```

SYSTEM INFO
Scan Rate (scans/sec): 999      Belt Speed (m/s): 1.55
Tach Rate (cnts/sec) : 2429    Belt Speed (ft/min): 306

DECODER COUNTERS
Scan Ints:      14796      DSP Codes:      59214
Triggers:      59548      DSP Triggers:   960
Process L0:    25824      Process L1:     0
Max Elements L0: 310      Max Elements L1: 0
Queue Size:    1          Queue Max:      9
Mem Alloc Err: 0          Memory Full:    0

SCAN DATA EXCEPTION COUNTERS
Missed DMA:    0          Missed QDMA:    0
Xfer Overflow: 0          Xfer Bad Length: 0
ASTRA Seg Err: 0          Invalid Leg No: 0
Low Term Count: 0         High Term Count: 0
Motor Var Cnt: 0

ARM Restarts:  0          DSP Restarts:   0

```

- **Message Log:** displays messages logged since the last clear command.

```
0-00:00:00.723: APD Read: DAC/Temp Ref: 243/6400
0-00:00:00.723: APD Read: Gain/Offset/Min/Max/Type: -1/-1/-1/-1/-1
0-00:00:00.725: APD DAC Initialized.
0-00:00:00.852: ADC Configuration Complete.
0-00:00:00.959: Loading FPGA file XLC_v20_0_0_0.fpga.
0-00:00:03.938: FPGA device id: 4c55.
0-00:00:03.938: FPGA version: 6.0(0).
0-00:00:06.378: Loading DSP file Decoder_release_v1_8_17_0.dsp.
0-00:00:06.678: DSP load complete.
0-00:00:06.678: Scan Engine Started.
0-00:00:06.679: FPGA Buffer Export Task Started
0-00:00:14.664: Motor Speed Threshold set to 0xFFFF.
0-00:00:14.664: FIR Filter Coefficients Loaded.
0-00:00:14.664: Scan FOV set to 88 deg (off=1562 len=21420)
0-00:00:15.263: Ethernet Initialization Complete.
0-00:00:15.263: Web Server Initialization Complete.
0-00:00:16.665: DSP Version 1.8.17 Started.
0-00:00:16.665: Scan Engine Initialized.
0-00:00:16.686: IsAlone=0 IsMaster=0 NumDevices=3
Powered On Time: 0-00:38:22.825
```

4. Click **Clear** to clear out the **Message Log**.

---

## Utilities

Use the Utilities menu selections to backup, restore, and update system firmware, or to reboot the scanner. The Utilities windows include:

[“Utilities | Backup or Restore” on page 184](#)

[“Utilities | Reboot” on page 186](#)

[“Utilities | Update Firmware” on page 187](#)

[“Utilities | Launch Genius” on page 189](#)

[“Utilities | Help” on page 190](#)

## Utilities | Backup or Restore

Use **Backup or Restore** to save all the settings to the device and backup the settings to the backup module and/or file.

To use the **Backup or Restore** functions:

1. In the menu under **Utilities**, click **Backup or Restore Info**. The Backup or Restore window opens.

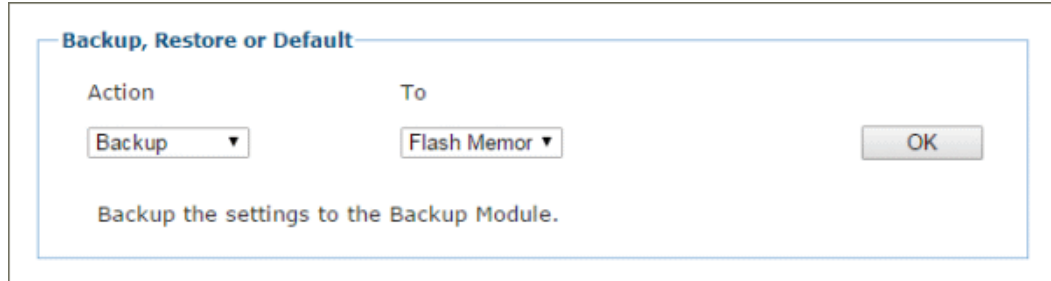

2. From the drop-down lists shown, select an **Action** and a **To/From** option.

### **Backup** Flash Memory

When this option is selected, click OK to save the settings to the Backup Module (BM100) in the CBX Connection Box. A progress box displays the percent complete of the save operation.

Utilities | Backup or Restore

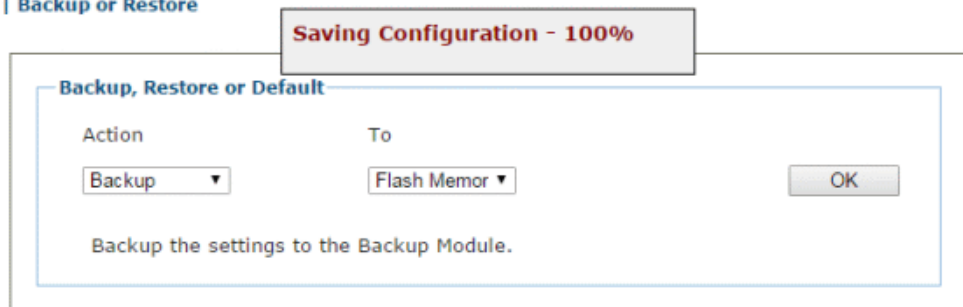

### File

When this option is selected, click OK to download the file to your computer. The file can then be saved to an appropriate backup folder.

### **Restore** Flash Memory

When this option is selected, click OK to retrieve the settings to the Backup Module in the CBX or the SD card in the SC5000. A progress box displays the percent complete of the restore operation.

### File

When this option is selected, a Choose File button is revealed. Click Choose File to open a file browser and locate the settings.txt file to be restored. When the file has been located and selected, click OK to save the file to the device.

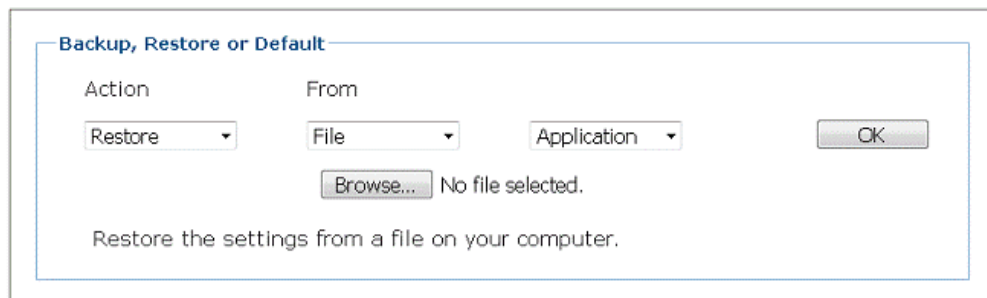

### Application

When File option is selected, you can chose from one of the following to restore:

**Application** – restore just application settings

**App and Env** – restore all settings including Ethernet and Packtrack

**All** – restore all

### **Default**

#### **Application**

When this option is selected, click OK to restore application settings to Factory defaults, except for Ethernet and PackTrack.

#### **App and Env**

When this option is selected, click OK to restore all settings including Ethernet and Packtrack.

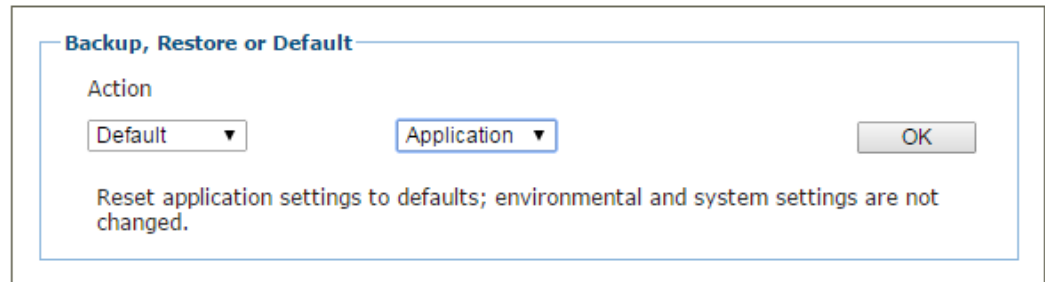

### **All**

When this option is selected, click OK to COMPLETELY RESET the scanner to Factory configuration.

## Utilities | Reboot

Use the **Reboot** window to restart the scanner or system.

To use the **Reboot** function:

1. In the menu under **Utilities**, click **Reboot**. The Reboot window opens.

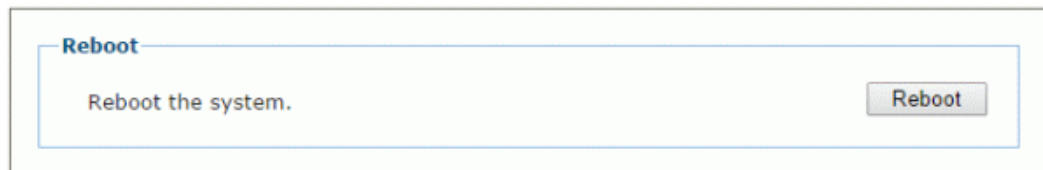

2. Click **Reboot**. A confirmation box appears.

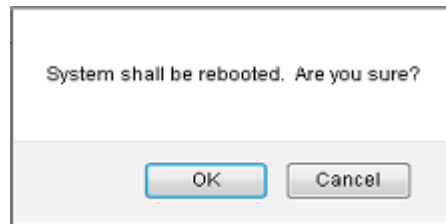

3. Click **OK** to reboot the system, or click **Cancel** to return to the reboot window.

## Utilities | Update Firmware

### WARNING



Use **Update Firmware** to reload the scanner system firmware.

This function should only be performed under the guidance of Datalogic Technical Support.

To Extract Image:

1. In the menu under **Utilities**, click **Update Firmware**. The Update Firmware window opens.

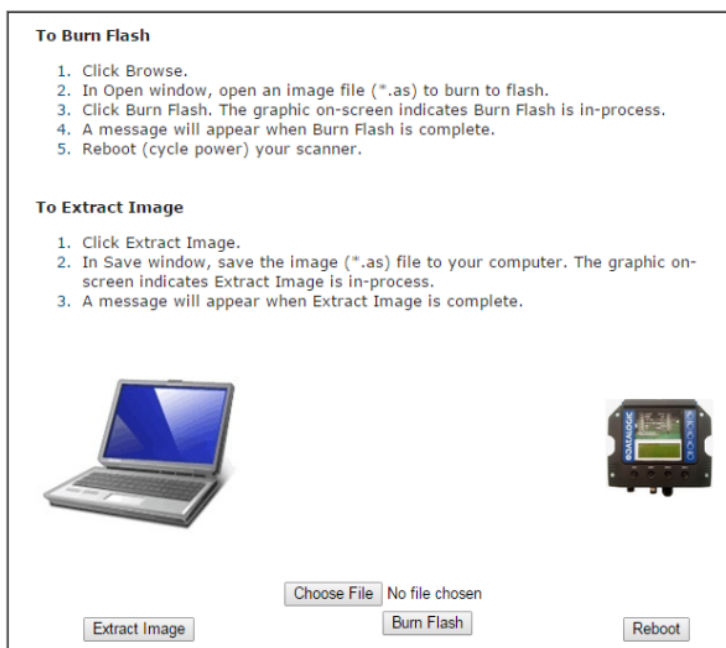

2. Click **Extract Image**. A confirmation box appears.

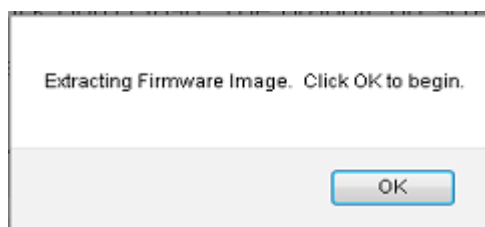

3. Click **OK** to continue
4. The graphic on screen indicates **Extract Image** is in-process. A message will appear when **Extract Image** is complete.

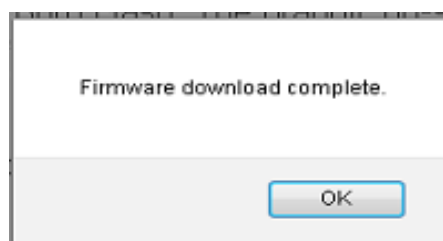

Depending upon the computer settings of the device interfacing with the scanner, you may be prompted to save the image to a location, or it may automatically save it to the PC's download folder.

**To Burn Flash:**

1. Click **Choose File**. In the browse window, select an image file (\*.as) to burn to flash.



**The appearance of these functions may vary from browser to browser.**

2. Click **Burn Flash**. The graphic on-screen indicates **Burn Flash** is in-process.
3. A message will appear when **Burn Flash** is complete.

**To Reboot the System:**

1. Click **Reboot**. A confirmation box appears.

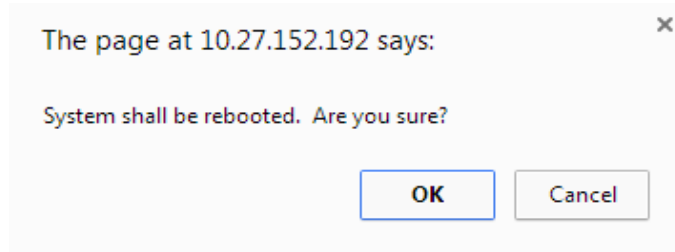

2. Click **OK** to reboot the system, or click **Cancel** to return to the reboot the window without restarting the system.



## Utilities | Launch Genius

Use Launch Genius to launch the legacy configuration tool.

### To Launch Genius:

1. In the menu under Utilities, click Launch Genius. The Launch Genius window opens.

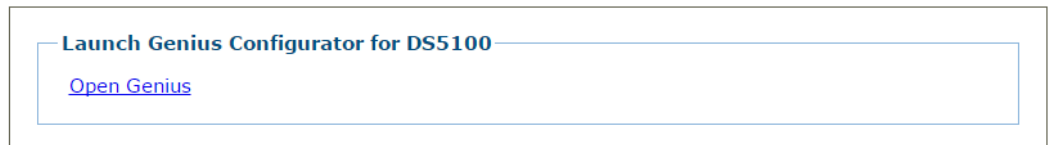

2. Click Open Genius.



**Genius is only used when the DS5100 scanners are connected to the SC5000.**

## Utilities | Help

e-Genius provides complete online help.

To use the Help system:

In the menu under **Utilities**, click **Help**. The Online Help window opens.

The **Welcome** page provides important product information as well as three ways to find specific help information: **Contents**, **Index**, and **Search**.

To display contextual help for a current window:

**SC5000 Controller e-Genius User Interface Online Help**

[Welcome](#)  
[Welcome](#)  
[User\\_Interface](#)  
[Modify\\_Settings](#)  
[Diagnostics](#)  
[Utilities](#)

**WELCOME TO SC5000/DS8110/DX8210 E-GENIUS ONLINE HELP**

The DS8110/DX8210 long range bar code scanners provide fully automated, industrial quality line and omnidirectional bar code identification. The SC5000 Controller provides system master control for large scanning arrays of tunnels. e-Genius for these products provides an easy-to-use series configuration and diagnostics features that enable you to set up your scanning system..

Click on any of the links below to learn how to access and use some of the DS8110/DX8210 and SC5000's best features:

[Getting\\_Started](#)  
[e-Genius\\_Basics](#)  
[Modify\\_Settings](#)  
[Device\\_Settings](#)  
[Diagnostics](#)  
[Utilities](#)

**Contact**

[Website: www.datalogic.com](http://www.datalogic.com)  
 Datalogic S.r.l.  
 Via S. Vitalino 13  
 40012 Calderara di Reno  
 Italy

© 2015-2018 Datalogic S.p.A. and its Group companies w ALL RIGHTS RESERVED. w Protected to the fullest extent under U.S. and international laws. Copying or altering of this document is prohibited without express written consent from Datalogic S.p.A.

Datalogic and the Datalogic logo are registered trademarks of Datalogic S.p.A. in many countries, including the U.S. and the E.U.

All other brand and product names are trademarks of their respective owners.

Datalogic shall not be liable for technical or editorial errors or omissions contained herein, nor for incidental or consequential damages resulting from the use of this material.

**DATALOGIC**  
THE VISION IS YOURS

Click the **Help Icon**  displayed at the top right of the screen. A help window appears, providing you with information for that specific page.

Click links to the Contents, Index, and Search options on the left of the help window.



# Chapter 5

## Barcode Scanning Features

This chapter provides details on how the DS8110 Barcode Scanning System functions during normal operation. It also helps familiarize the user with status indicator LEDs, Control Panel operation, system setup, and how the scanners can be easily and quickly replaced with a new unit if necessary.

WARNING



The procedures outlined in this chapter should only be performed by a Datalogic trained technician.

For further information on training, contact us through the Datalogic website at [www.datalogic.com](http://www.datalogic.com).

### First-time Startup



Before starting up or testing the scanner, it must be connected to a CBX510 Connection Box or an SC5000 Controller depending on the system configuration.

On initial power-up, the DS8110 performs a series of self-diagnostic and LED tests. The complete power-up sequence takes about 20 seconds. When the **READY** LED flashes and turns a steady green the power-up sequence is complete, and the scanner is operational.

### Default Parameters

The barcode scanners are shipped from the factory with these defaults:

- Default Password: DLA
- Control Panel Buttons Enabled
- Code 128 (10–30 characters), Code 39
- IP address HOST (ETH1) 172.27.101.220; Setup (ETH2) 192.168.3.100

Perform the following setup procedure using these defaults or configure your Barcode scanner with your application's parameters using **e-Genius**.

## Check Operations Using Test Mode



Perform the following test using a bar code that matches the default parameters. A barcode test chart is included in the box with each scanner, and a code from the chart can be used to perform the test. If the default parameters have been changed, you must enable the control panel buttons and the other default parameters listed.

To quickly check DS8110 operation:

1. Make sure the scanner is connected to a CBX510 or SC5000.
2. Apply power to the reader.
3. Press and hold the X-Press button until the first two red LEDs light, and then release the button.
4. Position a test barcode symbol approximately 750 mm [30 inches] from the reader. Skew the bar code symbol slightly.
5. The laser(s) should be scanning continuously during normal operations. (Observe the laser safety warnings.)
6. Observe the LEDs. The LEDs illuminate when the reader is scanning and decoding the bar code symbol, and indicate the rough read rate of the scan (*see*).

## Basic Installation Procedures with the CBX510

1. Mechanically install the scanner(s) according to the application drawing for your system.
2. Install the CBX510 according to the application drawing or in a location for best wiring access to scanner(s), encoder (tachometer), and photoelectric sensor.
3. If using more than one scanner, connect the host cable to ETH1 of the designated Master. Then wire ETH2 from the Master to ETH1 of the first Slave, and then from the first slave ETH2 to ETH1 of the next slave and so on.
4. Connect the 25 pin I/O communication cable from the scanner (Master only in multihead systems) to the CBX510.
5. Wire the encoder (tachometer) and photoelectric sensor into the CBX510 (*see sections* and ).
6. After the scanner(s), CBX510, and accessories have been carefully wired, apply power to the system.
7. When everything is powered up, connect a laptop to the ETH2 of the scanner (last slave in a multihead system.)
8. Open a browser and enter the default IP (192.168.3.100, *see section* .). **e-Genius** opens.



Detailed information on connecting a laptop to the system and using **e-Genius** is available in 'Getting Started' on page 43 .

9. Log on to **e-Genius**.

10. From the menu tree, select **Modify Settings | System Info.**



**System Info**

System Description

Role

Force Operation as a Standalone/Master

**Device Information**

Model	Dev	MAC Addr	Software Version	Description	
 	0	0007BE00EF8A	ARM_release_v2_0_0_0	<input type="text" value="DrumScanner"/>	<input type="button" value="ID"/>

**Additional Devices**

Send Barcodes to Non-Singulated Dimensioning System

11. Select **Standalone** (single head) or **Master** (multihead) from the **Role** drop-down list.
12. If Master is selected, the system is poled, and the other scanners are added to the Device information list.
13. From **Modify Settings | Global Settings | Operating Mode**, select a mode, trigger source, encoder setting.

**Operating Mode**

Operating Mode Selection

**Trigger Source**

Start Input Number

Start Input Active Level

Stop Phase Edge

**Mode Settings**

Distance from PS Line to Tx Line  mm

PS Line  mm

Minimum Pack Length  mm

Minimum Distance Error Behaviour

Minimum Distance Between Packs  mm

Window Dimension  mm

**Encoder Settings**

Physical Encoder

Encoder Step (hundredths of millimeter)

**Beam Shutter Settings**

Beam Shutter

PackTrack Beam Shutter Timeout

14. Adjust the barcode settings in **Modify Settings | Global Settings | Barcode Settings Table** according to the needs of your system.

**Barcode Settings**

Idx	Symbology	Minimum Length	Maximum Length
<input checked="" type="radio"/> 1	Code 128	10	12
<input type="radio"/> 2	Code 39	4	40
<input type="radio"/> 3	EAN-13	13	No Add On
<input type="radio"/> 4	UPC-A	12	No Add On
<input type="radio"/> 5	Disabled		

**Barcode 1**

Enable

Code Symbology

Minimum Label Length

Maximum Label Length

Match String Rule

Pattern Match String

**Options**

Decoding Safety

Bar Count

Match Direction Rule

15. in **Modify Settings | Global Settings | Barcode Configuration** select single, multiple, or logical combination of labels, based on your application.

**Barcode Configuration**

Code Combination

No Read Message

No Read String (max. 128 chars)

Multi Filters

16. Move through the menu tree to configure **Serial Ports, Ethernet, and Messaging** settings based on your application requirements.

17. In **Global Settings | Messaging | Message Format** change the **Message Tx Selection** to **After Reading Phase OFF**.

Messaging Formatting	
Role	Standalone ▼
Operating Mode Selection	Packtrack ▼
No Read Message	Local No Read(s) Mes ▼
Code Combination	Standard Multi Label ▼
Multiple Read Message	Disable ▼
Send All Multiple Read Labels	Disable ▼
Message Format	Advanced ▼
Message Tx Selection	After Reading Phase C ▼
Max. Tx Delay after Phase Off	On Decoding
Max. Tx Delay after Phase Off	After Reading Phase Off
	100 msec ▼

18. Run the **PackTrack** calibration procedure (*see section*).
19. When the scanner(s) has been configured and calibrated, backup the system configuration using **Utilities | Backup or Restore**. It is recommended to save the system parameters to the backup module on the CBX510 and to a file on your computer.

Backup, Restore or Default		
Action	To	
Backup ▼	Flash Memo ▼	OK
Backup the settings to the Backup Module in the CBX.		

20. Select **Backup** from the **Action** drop-down list, and select **Flash Memory** from the **To** drop-down list.
21. Click OK. The following message will be displayed.

### Saving Configuration

22. Next, select **Backup** from the **Action** drop-down list, and select **File** from the **To** drop-down list.
23. Click **OK** to download the configuration text file (param.txt) to your computer.



## Basic Installation with SC5000 Controller

1. Mechanically install the scanners according to the application drawing for your system.
2. Install the SC5000 according to the application drawing or in a location for best wiring access to scanner(s), encoder (tachometer), and photoelectric sensor.
3. Connect the host cable to the HOST of the SC5000 (*see figure below*). Next, wire ETH2 from the SC5000 to ETH1 of the first Slave, and then from the first slave ETH2 to ETH1 of the next slave and so on. If wiring the scanners in a complete ring configuration, connect ETH2 of the last slave in the series to ETH1 of the SC5000.

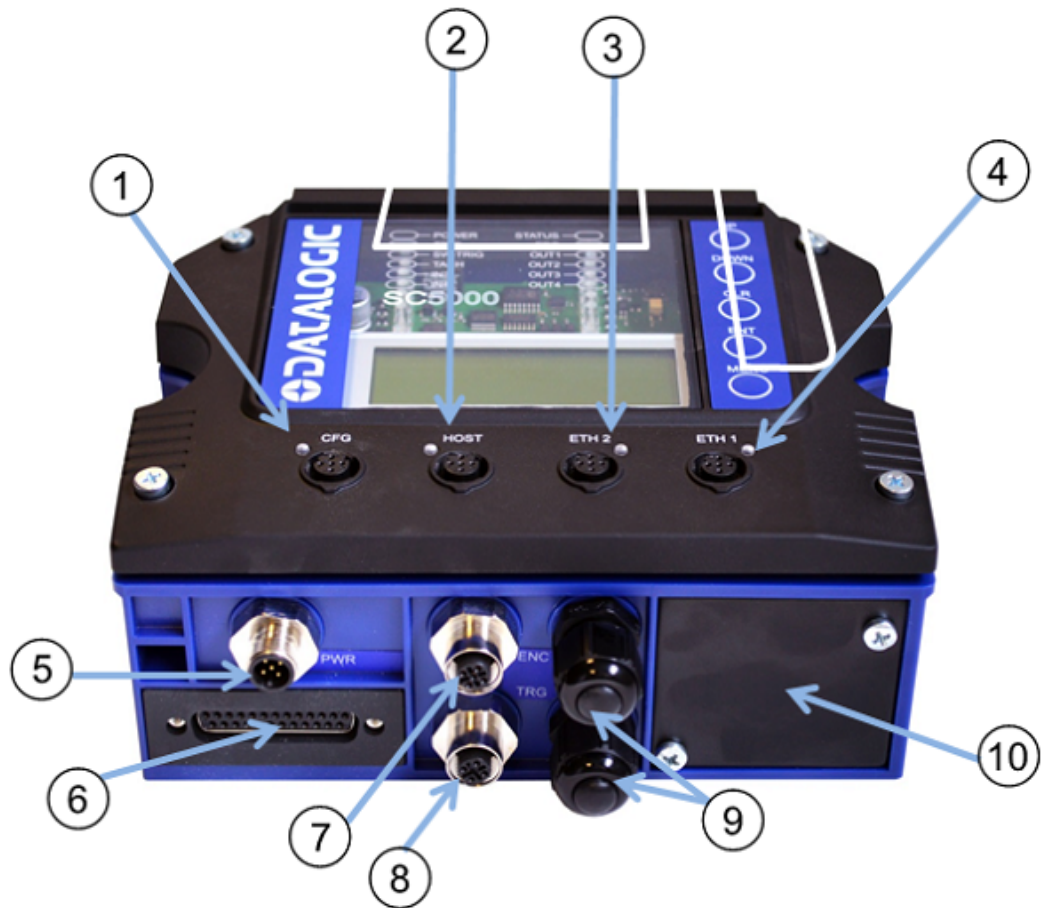

- |   |                            |   |                                    |
|---|----------------------------|---|------------------------------------|
| ① | CFG - Configuration        | ⑥ | 25-Pin D, Scanner Connector        |
| ② | Host                       | ⑦ | ENC – Encoder/Tachometer           |
| ③ | ETH2 – EBC scanner network | ⑧ | TRG – Trigger/Photoelectric Sensor |
| ④ | ETH1 – EBC scanner network | ⑨ | Watertight Wire Seals              |
| ⑤ | PWR - Power                | ⑩ | Connector Add-On Panel             |

4. Connect the encoder (tachometer) and photoelectric sensor (trigger) to the bottom of the SC5000 Controller (*see figure above*).
5. Connect the (unpowered) Power supplies to the scanners and SC5000.

6. After the scanner(s), SC5000, and accessories have been carefully wired, apply power to the system.
7. When everything is powered up, connect a laptop to the CFG port on the front of the SC5000. In a open (non-ring) system, the laptop can be connected to ETH2 of the scanner.
8. Open a browser and enter the default IP (192.168.3.100, *see section .*). **e-Genius** opens.



Detailed information on connecting a laptop to the system and using **e-Genius** is available in Chapter .

9. Log on to **e-Genius** (*see section .*).
10. From the menu tree, select **Modify Settings | System Info.**

**System Info**

System Description

Role

Enable Automatic Slave Replace

**Master Tools**

**Device Information**

Model	Dev	MAC Addr	Software Version	Description	
	0	0007BE0099C2	ARM_release_v2_0_0_0	SC5000	
	1	000E13040075	ARM_release_v2_0_0_0	DrumScanner	ID
	2	000E13041212	ARM_release_v2_0_0_0	DrumXScanner	ID
	3	000E13040114	ARM_release_v2_0_0_0	TableXScanner	ID
	4	0007BE00DAF6	ARM_release_v2_0_0_0	TableScanner	ID

**Additional Devices**

Send Barcodes to Non-Singulated Dimensioning System

**Dimensioning System Info**

IP Address

Port Number

Enable Tach Sync

11. If **Master** is selected, the system is poled, and the other scanners are added to the Device information list. The SC5000 Controller always serves as the Master when used.
12. From **Modify Settings | Global Settings | Operating Mode**, select a mode, trigger source, encoder setting.

The screenshot displays a web-based configuration interface for the SC5000 Controller, organized into several sections:

- Operating Mode:** A dropdown menu is set to "Packtrack".
- Trigger Source:** Three dropdown menus are configured: "Start Input Number" is "Trigger (Input 1)", "Start Input Active Level" is "Active Closed", and "Stop Phase Edge" is "Trailing".
- Mode Settings:** A series of input fields and dropdowns: "Distance from PS Line to Tx Line" (2499 mm), "PS Line" (0 mm), "Minimum Pack Length" (51 mm), "Minimum Distance Error Behaviour" (Compose), "Minimum Distance Between Packs" (30 mm), and "Window Dimension" (15 mm).
- Encoder Settings:** "Physical Encoder" is set to "Enable" and "Encoder Step (hundredths of millimeter)" is set to 64.
- Beam Shutter Settings:** "Beam Shutter" is set to "Triggered" and "PackTrack Beam Shutter Timeout" is set to "10 min".

At the bottom of the interface, there are three buttons: "Update All", "Reset All", and "Reset Page".

13. Adjust the barcode settings in **Modify Settings | Global Settings | Barcode Settings Table** according to the needs of your system.
14. Adjust the barcode settings in **Modify Settings | Global Settings | Barcode Settings Table** according to the needs of your system.

**Barcode Settings**

Idx	Symbology	Minimum Length	Maximum Length
<input checked="" type="radio"/> 1	Code 128	10	12
<input type="radio"/> 2	Code 39	4	40
<input type="radio"/> 3	EAN-13	13	No Add On
<input type="radio"/> 4	UPC-A	12	No Add On
<input type="radio"/> 5	Disabled		

**Barcode 1**

Enable

Code Symbology

Minimum Label Length

Maximum Label Length

Match String Rule

Pattern Match String

**Options**

Decoding Safety

Bar Count

Match Direction Rule

15. In **Modify Settings | Global Settings | Barcode Configuration** select single, multiple, or logical combination of labels, based on your application.

**Barcode Configuration**

Code Combination

No Read Message

No Read String (max. 128 chars)

Multi Filters

16. Move through the menu tree to configure **Serial Ports, Ethernet, and Messaging** settings based on your application requirements.
17. In **Global Settings | Messaging | Message Format** change the **Message Tx Selection** to **After Reading Phase OFF**.

Messaging Formatting	
Role	Standalone
Operating Mode Selection	Packtrack
No Read Message	Local No Read(s) Mes
Code Combination	Standard Multi Label
Multiple Read Message	Disable
Send All Multiple Read Labels	Disable
Message Format	Advanced
Message Tx Selection	After Reading Phase C On Decoding After Reading Phase Off
Max. Tx Delay after Phase Off	100 msec
Max. Tx Delay after Phase Off	100 msec

18. Run the **PackTrack** calibration procedure (*see section*).
19. When the scanner(s) has been configured and calibrated, backup the system configuration using **Utilities | Backup or Restore**. It is recommended to save the system parameters to *Flash Memory* on the SC5000 and to a *File* on your computer.

Backup, Restore or Default	
Action	To
Backup	Flash Memo
OK	
Backup the settings to the Backup Module in the CBX.	

20. Select **Backup** from the **Action** drop-down list, and select **Flash Memory** from the **To** drop-down list.
21. Click **OK**. The following message will be displayed.

### Saving Configuration

22. Next, select **Backup** from the **Action** drop-down list, and select **File** from the **To** drop-down list.
23. Click **OK** to download the configuration text file (param.txt) to your computer.



## LED Indicators

The DS8110 barcode scanners have several tube LEDs spanning the top and front panel.

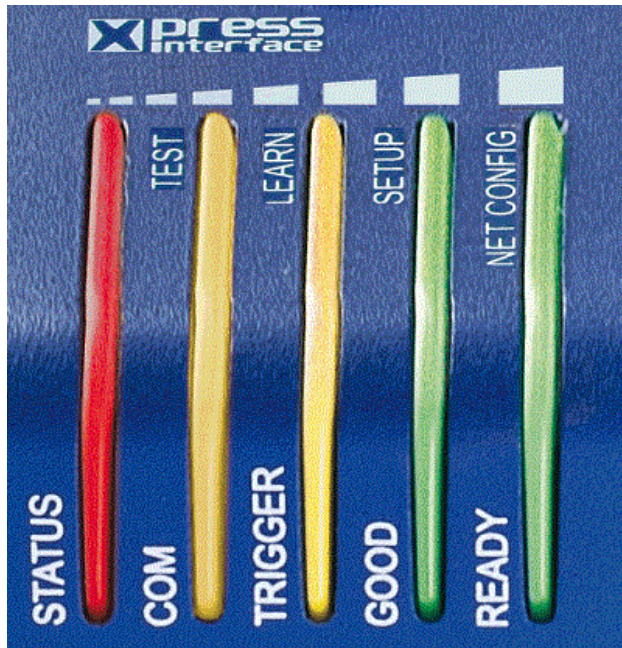

The indicators have the following meanings:

For alternate functions, see *X-Press™ Human Machine Interface* below.



When operating mode is set to PackTrack, the COM/TEST and TRIGGER/LEARN LEDs are inactive on slave Scanners.

LED	Description
STATUS	Flashes RED on a NO READ
COM/TEST	Flashes YELLOW to indicate data transmitting from main serial port.
TRIGGER/LEARN	Flashes YELLOW to indicate an active external presence sensor.
GOOD/SETUP	Flashes GREEN to indicate a barcode was successfully read.
READY/NET-CONFIG	Solid GREEN indicates the device is ready to operate.

## Control Panel Buttons



### X-PRESS™ Human Machine Interface

X-Press is the intuitive Human Machine Interface designed to improve ease of installation and maintenance.

Status information is clearly presented by means of the five colored LEDs, whereas the single push button gives immediate access to the following relevant functions:







- **TEST** with bar graph visualization to check static reading performance
- **LEARN** to self-detect and auto-configure for reading unknown codes
- **SETUP** to allow the open Ethernet port in the last slave scanner in a Master/Slave system to work as a dedicated setup port
- **NETCONFIG** to locate and configure slave scanners in a array (tunnel)

### X-PRESS Functions







Quick access to the following functions is provided by an easy procedure using the push button:

1. Press the button (the Status LED will give a visual feedback).
2. Hold the button until the specific function LED is on (**TEST**, **LEARN**, **SETUP**, or **NETCONFIG**).
3. Release the button to enter the specific function.







Once button is pressed and held, the cycle of LEDs activation is as follows:

	STATUS		
RED			
	COM	TEST	
RED			
	TRIGGER	LEARN	
YELLOW			
	GOOD	SETUP	
GREEN			
	READY	NETCONFIG	
GREEN			

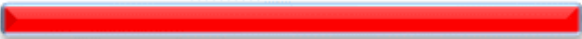
Release Button to Exit

	STATUS		
			
	COM	TEST	
			
	TRIGGER	LEARN	
			
	GOOD	SETUP	
			
	READY	NETCONFIG	
			

Release Button to enter Test Mode

	STATUS		
			
	COM	TEST	
			
	TRIGGER	LEARN	
			
	GOOD	SETUP	
			
	READY	NETCONFIG	
			



Release Button to enter **Learn Mode**

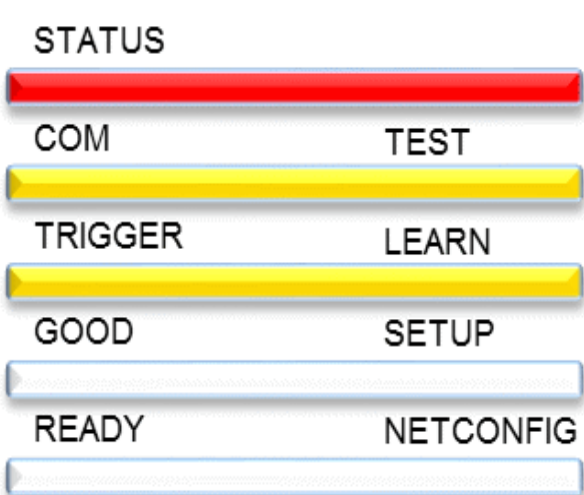

Release Button to enter **Setup Mode**

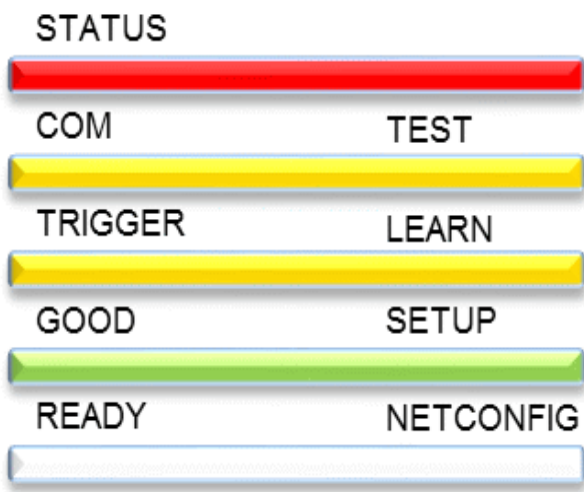

Release Button to enter **Network Configuration Mode**

**Test Mode**

Once entered, the five LEDs are activated and if the scanner starts reading bar-codes. The LEDs indicate the read rate percentage. In case of a NO READ condition, only the Status LED is on and blinks.

The LEDs indicate the read rate percentage as follows:

To exit the **Test Mode**, press the X-PRESS push button once.

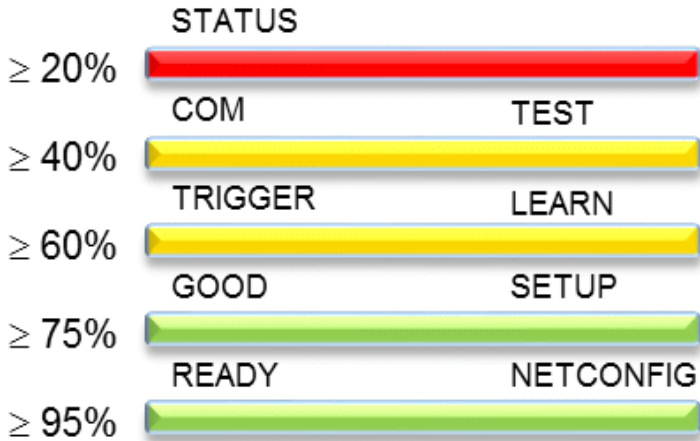



**By default, the Test exits automatically after two minutes**

### Learn

Once entered, the **LEARN** LED blinks and scanner starts a procedure to automatically detect and recognize barcodes, which are presented to it.

Place a barcode into the scan line and the **LEARN** LED goes solid for a short time as Processing and Decoding parameters are successfully saved.

If the calibration cannot be reached after a timeout of about 3 (three) minutes, the scanner will exit Learn Mode without saving the parameters.

### Setup

This mode is available in a master/slave system (scanner as master, not an SC5000.)

This option applies to the last slave scanner in the daisy-chain system, allowing its open Ethernet port to work as a dedicated setup port.

In practice, you can always communicate using this port, but the Setup Mode turns off all of the other EBC traffic on that port.



**This option must only be applied to the last slave scanner in the EBC network. Applying this option to the other slaves will disrupt the EBC network.**

### Netconfig

Once entered from a Master scanner in a multi-scanner array (tunnel), the system detects and identifies Slave scanners in the array. The Slave scanners (and the Master) will then be available in **e-Genius** (*see chapter* ).

Press the X-Press button once again to exit.

## Restore Button and Other Functions

Function	Description
Scanner Replacement	Hold down <b>RESTORE</b> button until all LEDs turn on. After all LEDs go off, then READY LED comes back on. Parameters stored in the CBX510 are now being used in the scanner.
Software Recovery Mode	Hold down <b>X-Press</b> button while scanner is powered up.
Reset Scanner to Factory Defaults	Hold down <b>X-Press</b> and <b>RESTORE</b> buttons while scanner powers. When default is successful, all LEDs will flash 3 times.

## PackTrack™

**PackTrack** is a patented operating mode for Datalogic Omni-Directional Reading Stations used to read and correctly assign codes read on different packs when placed in the scanner Reading Area at the same time.

In fact, in the following example, the codes of two or more consecutive packs are found at the same time in the scanner reading area. Therefore, the condition occurs where, in the sequence of the two packs, the code of the second pack is read first, just before the code of the previous pack. A system without **PackTrack** would assign the code of the second pack to the first pack and vice versa, thus causing a gross error in sortation.

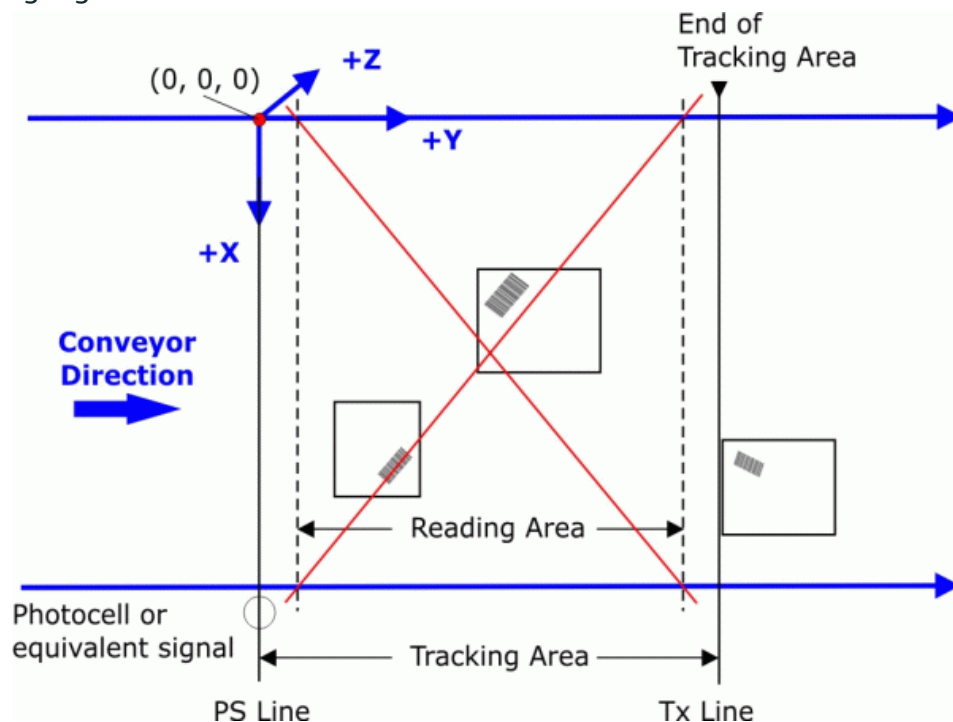

**PackTrack** uses a right-handed reference system where the **X** axis coincides with the Photoelectric Sensor line, the **Y** axis coincides with the conveyor direction, and the **Z** axis is oriented upwards from the conveyor (see figure below). The arrows point in the positive direction. The coordinate point of origin  $(0,0,0)$  is on the left edge of the conveyor as illustrated.

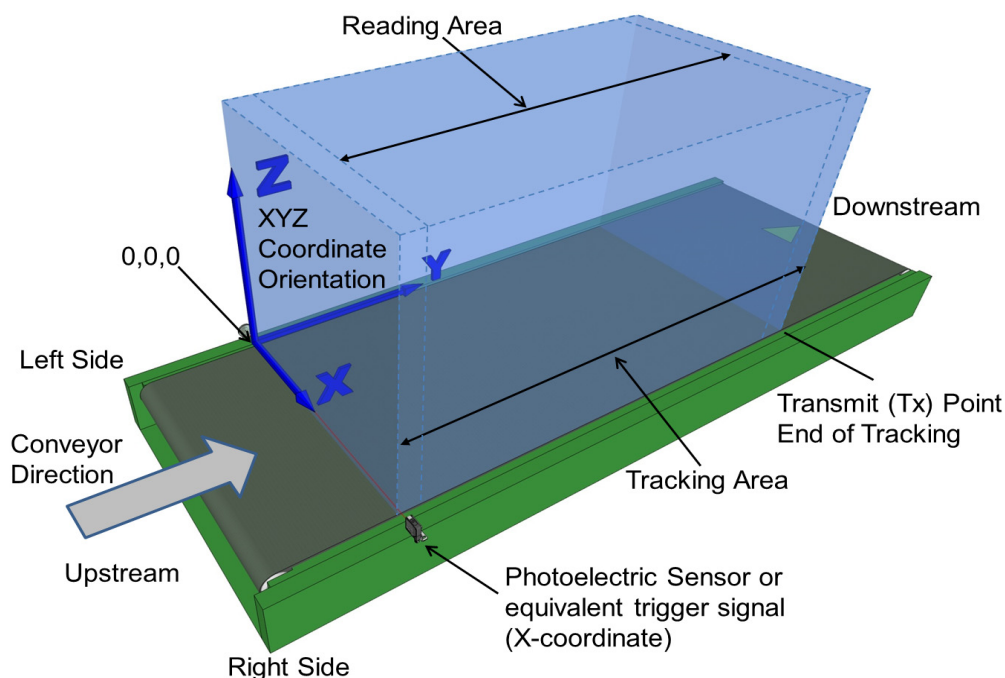

This coordinate system is absolute for the reading station, i.e. valid for all the scanners independently from their position or orientation with respect to the conveyor. For this reason, after the **PackTrack** configuration (and calibration) has been correctly performed, when a barcode is under the beam to be read by the scanners, its position is defined by the coordinates of its central point, independently from which scanner is reading it.

Step-by-step procedures for calibrating Top-Mounted (*see* ) and Side-Mounted (*see* ) barcode scanners are described below.

## Using the PackTrack Wizard

Before you begin calibration:

1. In **Modify Settings | Global Settings | Barcode Settings**, select and configure a system barcode.
2. In **Modify Settings | Global Settings | Barcode Configuration**, create a **Global No Read message** you can easily recognize, such as **NO READ**.
3. In **Modify Settings | Global Settings | Operating Mode**, select **PackTrack** as your **Operating Mode Selection**. Make sure the mode settings and encoder settings match your system parameters.
4. Navigate to **Diagnostics | Read Test**.
5. Place a system barcode in the scan line of the barcode scanner.
6. Click **Start Test**. The scanner should successfully read the barcode. If it doesn't, read successfully or registers a low read rate, check the system specifications for mounting distance and barcode specifications. Then make adjustments as necessary and repeat the test. If the scanner continues to have problems reading the barcode, contact Datalogic ([www.datalogic.com](http://www.datalogic.com)).

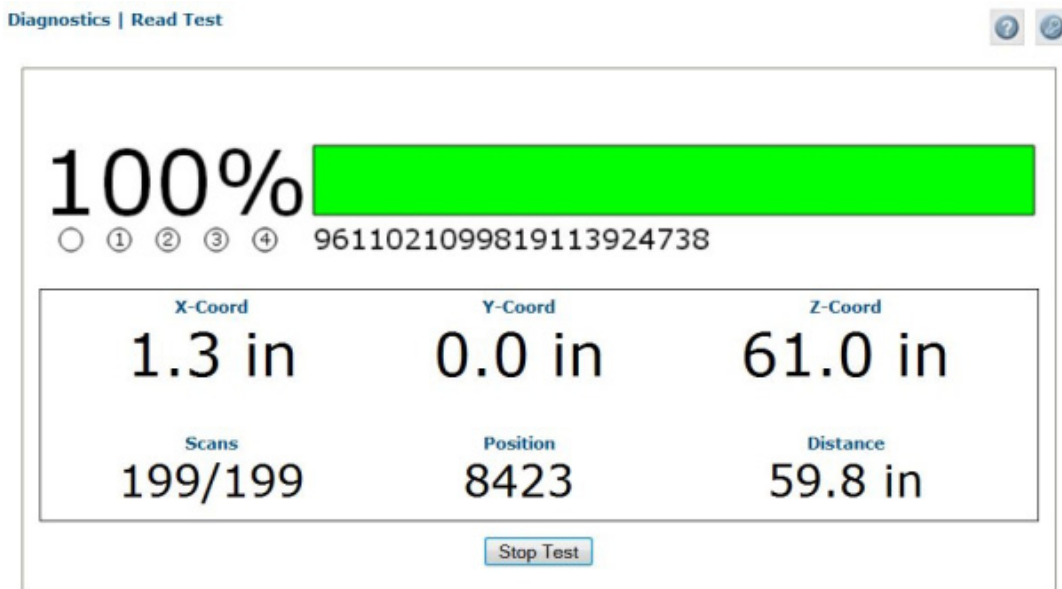

A read test tool has now been added to the bottom section of the **PackTrack Calibration Wizard**, which can supply the read rate and XYZ coordinates.

7. Repeat the test for both legs (each laser line of the X-pattern) of a DX8210 scanner.
8. Click **Stop Test**

**To access the PackTrack Wizard:**

1. In the tree menu under **Modify Settings**, navigate to **Device Settings | Device Name (if applicable) | Mounting**. The **Mounting** window opens.
2. Select **PackTrack Calibration** from the Mounting Specifications drop-down list.

The screenshot displays the 'Scanner Mounting' configuration window. At the top, the 'Calibration Method' is set to 'PackTrack Calibration'. Below this, the 'Packtrack Calibration Wizard' section contains a 'Launch Wizard' button. The 'Calibration Adjustment' section shows a 'Y Adjustment' of '0 mm'. The 'PackTrack Calibration Coefficients' section lists nine items, each with a value of '0.000000'. At the bottom, there are three buttons: 'Update All', 'Reset All', and 'Reset Page'.

Calibration Item	Value
Calibration Item 1	0.000000
Calibration Item 2	0.000000
Calibration Item 3	0.000000
Calibration Item 4	0.000000
Calibration Item 5	0.000000
Calibration Item 6	0.000000
Calibration Item 7	0.000000
Calibration Item 8	0.000000
Calibration Item 9	0.000000

3. Click **Launch Wizard**. The **PackTrack Calibration Wizard** window opens.

### PackTrack Calibration

Initialized (leg=1)

<b>X-Coord (mm)</b> <input type="text"/> <input type="text"/> <input type="text"/>	<b>Y-Coord (mm)</b> <input type="text"/> <input type="text"/> <input type="text"/>	<b>Z-Coord (mm)</b> <input type="text"/> <input type="text"/> <input type="text"/>	<input type="button" value="Calibrate 1"/> <input type="button" value="Calibrate 2"/> <input type="button" value="Calibrate 3"/>
<input type="button" value="Compute Result"/>			
<input type="button" value="Update All"/>			

<b>Read %</b>	<b>Measured X-Coord (mm)</b>	<b>Measured Y-Coord (mm)</b>	<b>Measured Z-Coord (mm)</b>
0%	0	0	0
<input type="button" value="Start Test"/>			

- The **PackTrack Calibration Wizard** asks you to physically measure and enter barcode coordinates for the extremes of your barcode scanning system. You will measure and enter XYZ coordinates for barcodes in three different locations along the barcode scanners laser line(s) for each system scanner, as shown for **top-mounted** and **side-mounted** scanners in the illustrations below.



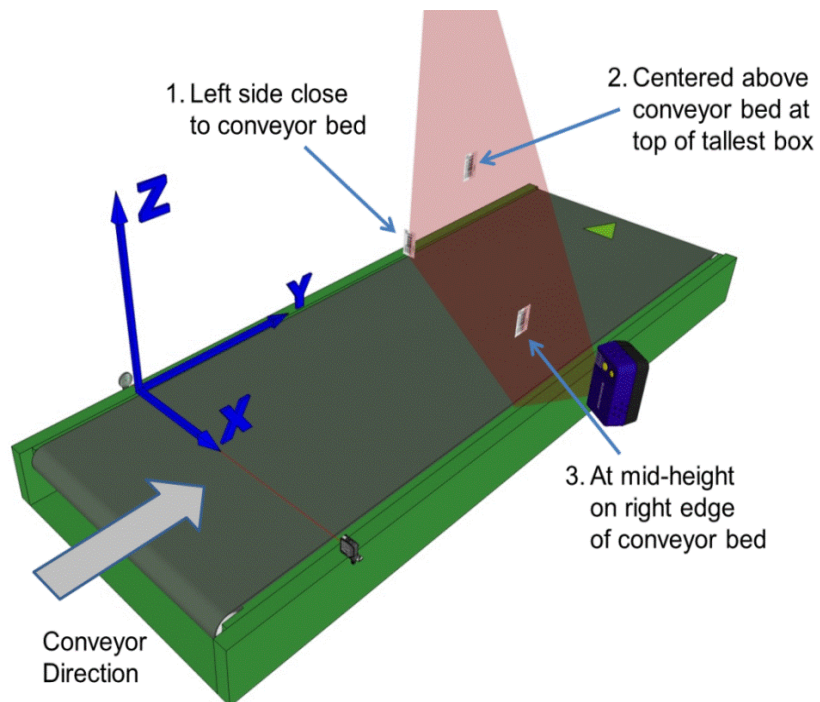
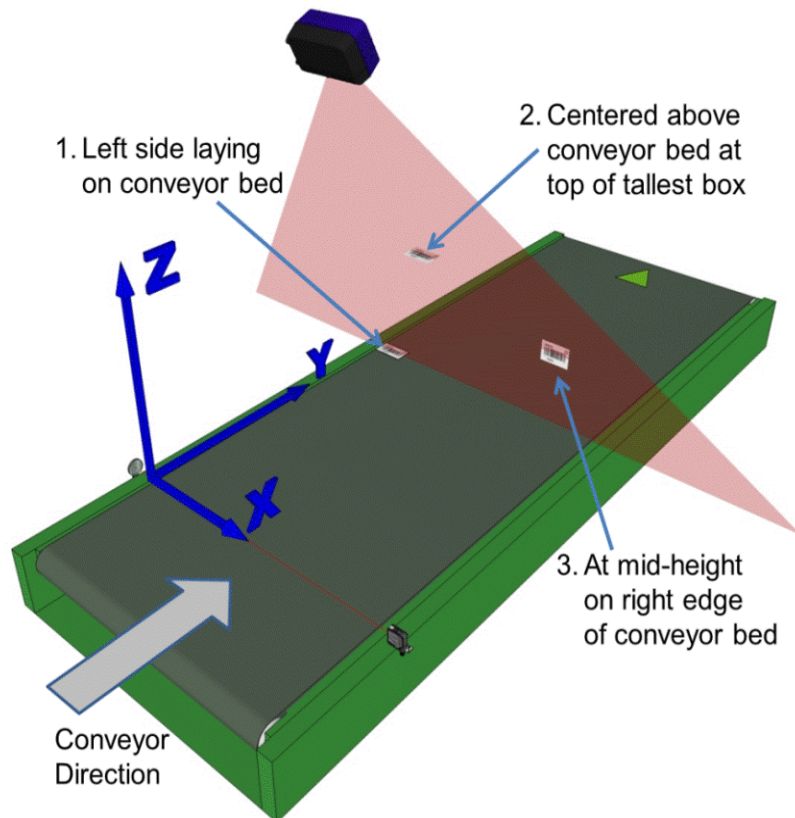

A barcode test chart is included in the box with each scanner, and a code from the chart can be used for the PackTrack calibration. You may also use a standard barcode from your specific application, however, test the code to make sure the scanner reads it at 100% using **Diagnostics | Read Test** in **e-Genius** (see )

## Top-Mounted Barcode Scanner Calibration Using PackTrack



It is not possible to illustrate every possible installation angle and scanner mounting position in this manual. Use the following steps as a general guide to calibrating each system scanner using barcodes in three positions. You will need to make adjustments to the label/box position based on your situation. It is, however, important to note the fixed XYZ coordinates of the conveyor.

With the belt stopped, measure and enter the barcode XYZ coordinate data for each scanner as follows:

1. Make sure that the intended scanner (in a multi-head system) has been selected from the drop-down lists at the top of the wizard window.
2. Start by laying a system barcode on the conveyor bed in the laser line as close to the left edge (X=0 edge) as possible. See illustration below.

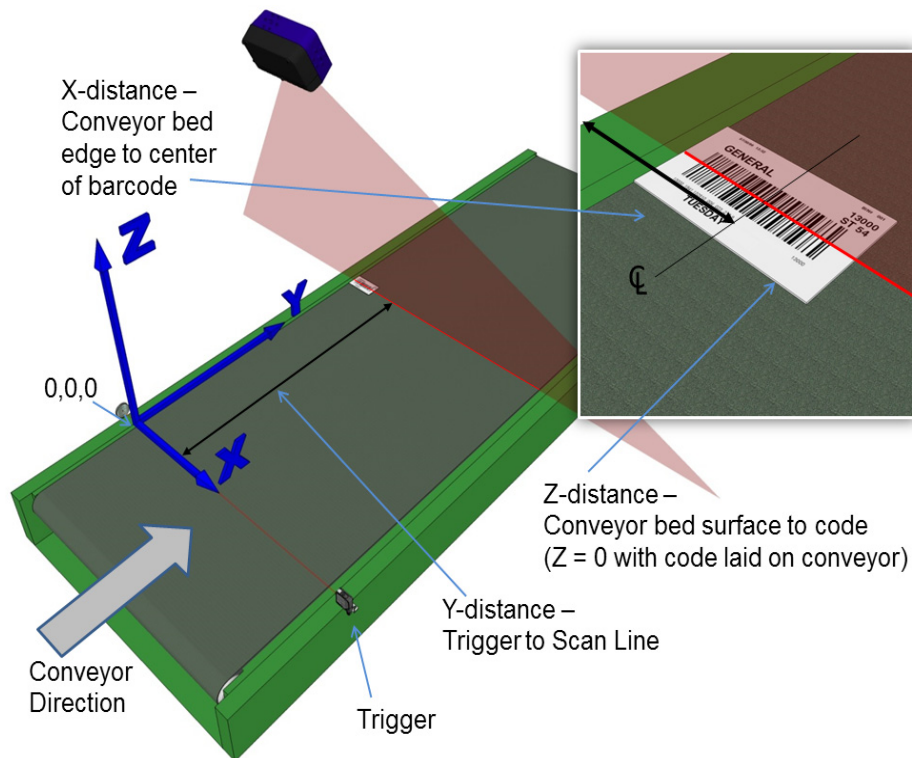

3. Measure the distance for X from the edge of the conveyor bed to the center of the barcode, and enter that distance in the first box under X-Coord (mm) in the PackTrack Calibration Wizard. Your measurements will likely differ from those shown below.

X-Coord (mm)	Y-Coord (mm)	Z-Coord (mm)
100		

4. Measure the distance for Y from the trigger (PS line) to the barcode scanner's laser line on the barcode, and enter that distance in the first box under Y-Coord (mm). Your measurements will likely differ from those shown below.



X-Coord (mm)	Y-Coord (mm)	Z-Coord (mm)
100	70	

5. Measure the distance for Z from the conveyor bed to the barcode, and enter that distance in the first box under Z-Coord (mm). Since the barcode is laying on the conveyor bed, the value should be "0."

X-Coord (mm)	Y-Coord (mm)	Z-Coord (mm)
100	70	0

6. Click **Calibrate 1**. PackTrack data is displayed for the first code.

**PackTrack Calibration**

Code 1 - X/Y/Z: 100.000000 / 70.000000 / 0.000000  
 (Leg 1) Dist/Angle: 1003.550000 / 0.118065

X-Coord (mm)	Y-Coord (mm)	Z-Coord (mm)
100	70	0

7. Next, place a barcode overhanging the top corner of the tallest box specified for your scanning system as shown in the illustration below. Center one edge of the box on the conveyor and align the other edge with the laser line as shown.

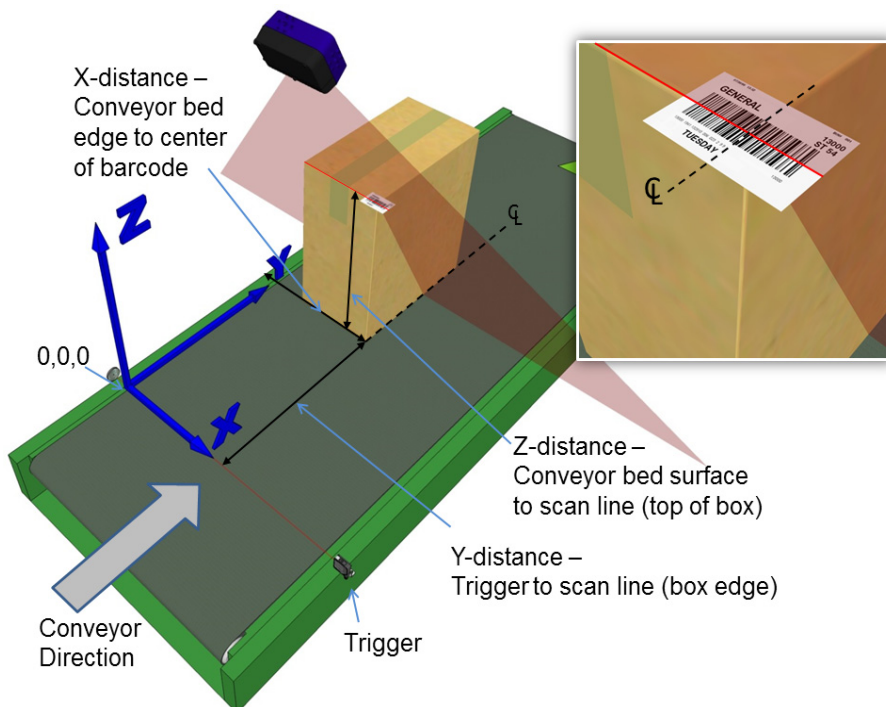

- Measure the distance for X from the left edge of the conveyor bed to the center of the barcode (centered side edge of box), and enter that distance in the first box under X-Coord (mm).

X-Coord (mm)	Y-Coord (mm)	Z-Coord (mm)
100	70	0
280		

- Measure the distance for Y from the trigger (PS line) to the barcode scanner's laser line on the barcode (back edge of box), and enter that distance in the first box under Y-Coord (mm).

X-Coord (mm)	Y-Coord (mm)	Z-Coord (mm)
100	70	0
280	165	

- Measure the distance for Z from the conveyor bed to the barcode (top of box), and enter that distance in the first box under Z-Coord (mm).

X-Coord (mm)	Y-Coord (mm)	Z-Coord (mm)
100	70	0
280	165	160

- Click Calibrate 2. PackTrack data is displayed for the second code.

**PackTrack Calibration**

Code 2 - X/Y/Z: 280.000000 / 165.000000 / 160.000000  
 (Leg 1) Dist/Angle: 816.225000 / -0.073688

X-Coord (mm)	Y-Coord (mm)	Z-Coord (mm)
100	70	0
280	165	160

12. Finally, place a system barcode on the back right edge of a box, about half-way up the scanner field of view as shown in the illustration below.

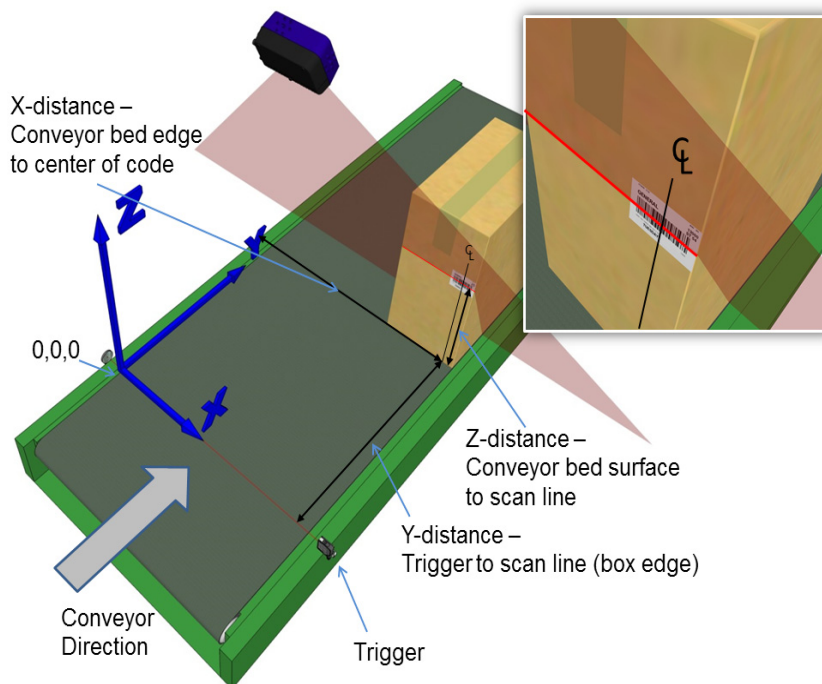

13. Measure the distance for X from the left edge of the conveyor bed to the center of the barcode, and enter that distance in the first box under X-Coord (mm).

X-Coord (mm)	Y-Coord (mm)	Z-Coord (mm)
100	70	0
280		

14. Measure the distance for Y from the trigger (PS line) to the barcode scanner's laser line on the barcode (back edge of box), and enter that distance in the first box under Y-Coord (mm).

X-Coord (mm)	Y-Coord (mm)	Z-Coord (mm)
100	70	0
280	165	

15. Measure the distance for Z from the conveyor bed to the laser line intersecting the barcode, and enter that distance in the first box under Z-Coord (mm).

X-Coord (mm)	Y-Coord (mm)	Z-Coord (mm)
100	70	0
280	165	160

16. Click Calibrate 3. PackTrack data is displayed for the third code.

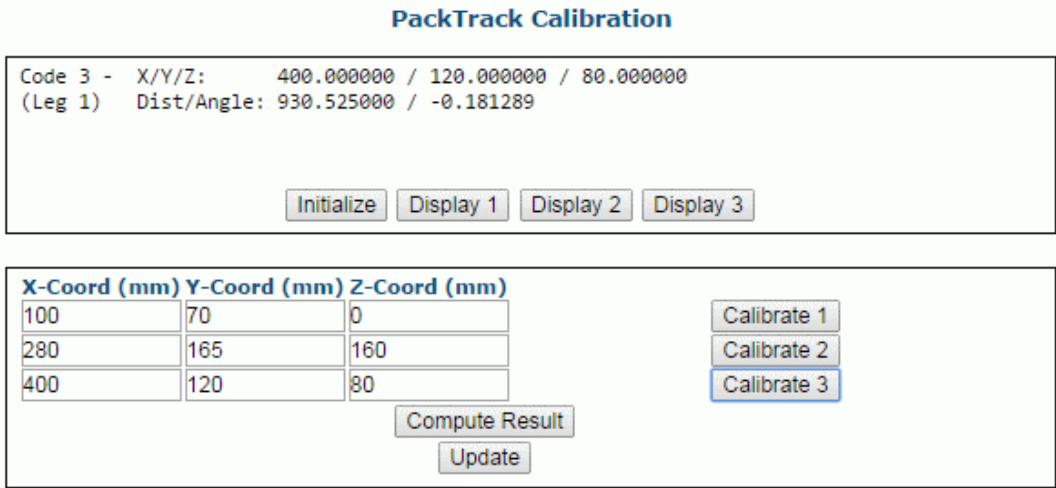

17. Click Compute Results. The results are displayed at the top of the PackTrack Calibration window.

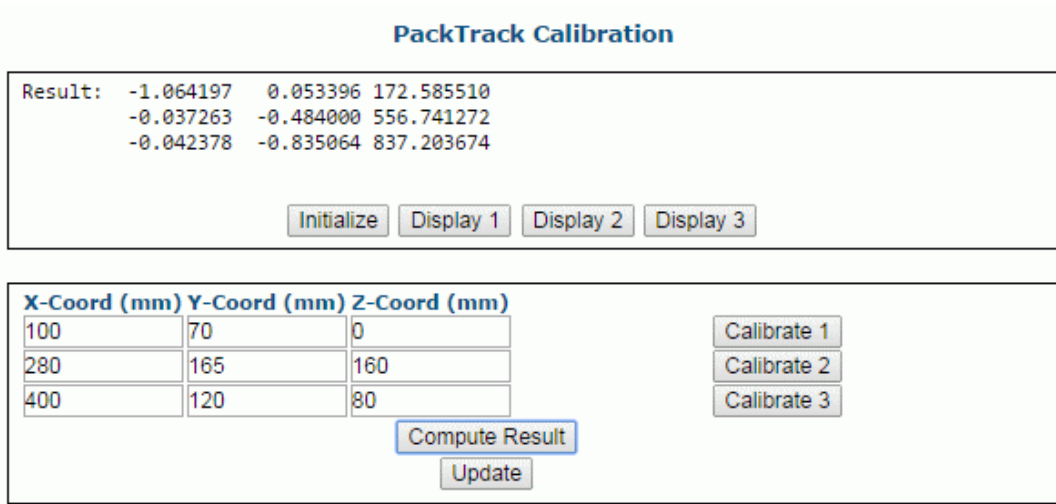

18. Click Update. "Update Successful" should be displayed in the PackTrack Calibration window.

19. Close the PackTrack Calibration Wizard window. PackTrack Calibration Coefficients have been populated on the Scanner Mounting widow.

PackTrack Calibration Coefficients	
Y Adjustment	0 mm
Calibration Item 1	-1.064197
Calibration Item 2	0.053396
Calibration Item 3	172.585510
Calibration Item 4	-0.037263
Calibration Item 5	-0.484000
Calibration Item 6	556.741272
Calibration Item 7	-0.042378
Calibration Item 8	-0.835064
Calibration Item 9	837.203674

20. When you have finished making changes, click Update All to save all pending changes, click Reset All to revert to all previously saved values, and click Reset Page to revert to previous saved values on the current page.

21. See Verifying PackTrack Calibration below.

## Side-Mounted Barcode Scanner Calibration Using PackTrack



It is not possible to illustrate every possible installation angle and scanner mounting position in this manual. Use the following steps as a general guide to calibrating each system scanner using barcodes in three positions. You will need to make adjustments to the label/box position based on your situation. It is, however, important to note the fixed XYZ coordinates of the conveyor.

With the belt stopped, measure and enter the barcode XYZ coordinate data for each scanner as follows:

1. Start by placing a system barcode hanging halfway past the back lower left edge of a box, and then place the box along the edge of the conveyor belt as shown in the illustration below.

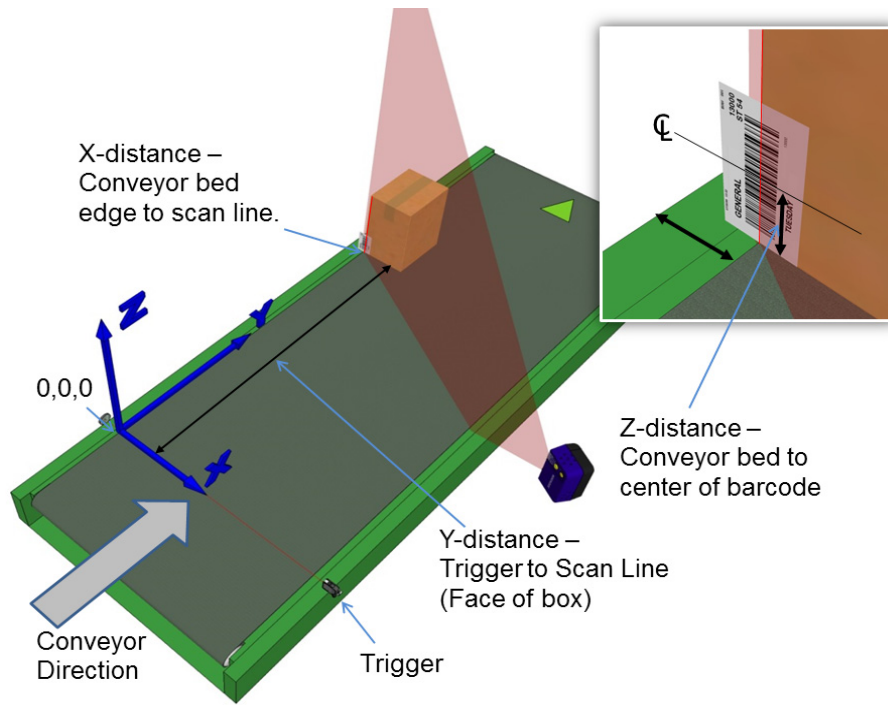

2. Measure the distance for X from the edge of the conveyor bed to the laser line centered on the barcode, and enter that distance in the first box under X-Coord (mm) in the PackTrack Calibration Wizard.

X-Coord (mm)	Y-Coord (mm)	Z-Coord (mm)
100		

3. Measure the distance for Y from the trigger (PS line) to the back edge of the box, and enter that distance in the first box under Y-Coord (mm).

X-Coord (mm)	Y-Coord (mm)	Z-Coord (mm)
100	70	

4. Measure the distance for Z from the conveyor bed to the center of the barcode, and enter that distance in the first box under Z-Coord (mm).

X-Coord (mm)	Y-Coord (mm)	Z-Coord (mm)
100	70	0

5. Click Calibrate 1. PackTrack data is displayed for the first code.



**PackTrack Calibration**

Code 1 - X/Y/Z:      100.000000 / 70.000000 / 0.000000  
 (Leg 1) Dist/Angle: 1003.550000 / 0.118065

X-Coord (mm)	Y-Coord (mm)	Z-Coord (mm)
100	70	0

6. Next, place a barcode overhanging the top corner of the tallest box specified for your scanning system as shown in the illustration below. Center the right edge of the box on the conveyor aligning the right back corner with the laser line as shown.

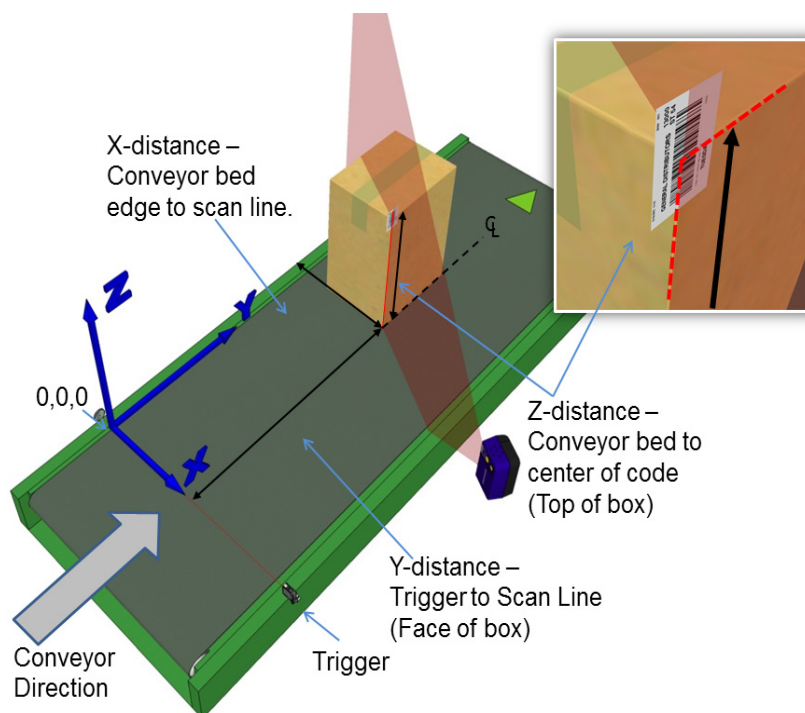

7. Measure the distance for X from the left edge of the conveyor bed to the center of the barcode (right edge of box), and enter that distance in the first box under X-Coord (mm).

X-Coord (mm)	Y-Coord (mm)	Z-Coord (mm)
100	70	50
280		

8. Measure the distance for Y from the trigger (PS line) to the back edge of the box, and enter that distance in the first box under Y-Coord (mm).

X-Coord (mm)	Y-Coord (mm)	Z-Coord (mm)
100	70	50
280	165	

9. Measure the distance for **Z** from the conveyor bed to the center of the barcode (top of box), and enter that distance in the first box under **Z-Coord (mm)**.

X-Coord (mm)	Y-Coord (mm)	Z-Coord (mm)
100	70	50
280	165	160

10. Click Calibrate 2. PackTrack data is displayed for the second code.

**PackTrack Calibration**

Code 2 - X/Y/Z: 280.000000 / 165.000000 / 160.000000  
 (Leg 1) Dist/Angle: 816.225000 / -0.073688

X-Coord (mm)	Y-Coord (mm)	Z-Coord (mm)
100	70	0
280	165	160

11. Finally, place a system barcode on the back right edge of a box, about half-way up the scanner field of view as shown in the illustration below.

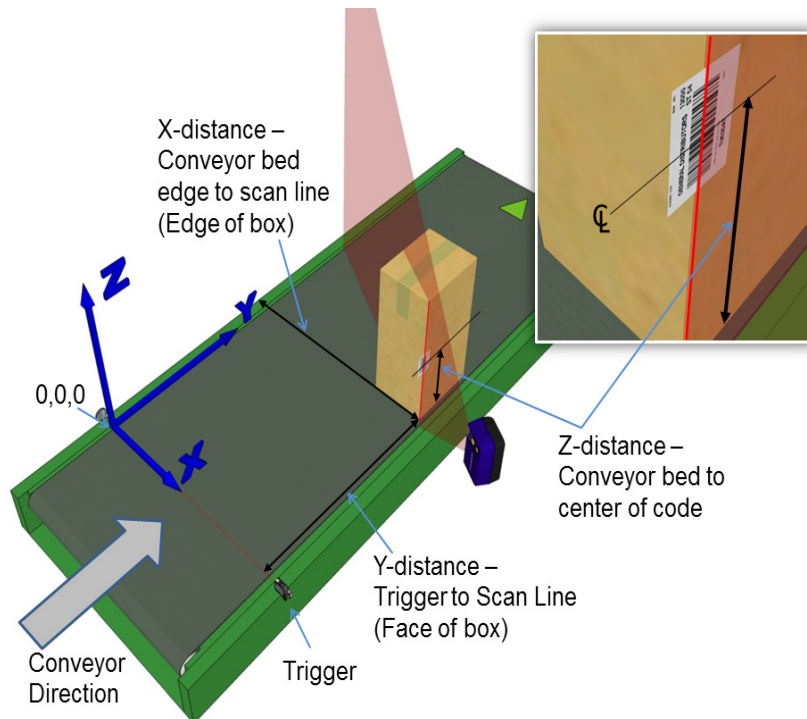



12. Measure the distance for **X** from the left edge of the conveyor bed to the center of the barcode, and enter that distance in the first box under **X-Coord (mm)**.

Your measurements will likely differ from those shown below.

X-Coord (mm)	Y-Coord (mm)	Z-Coord (mm)
100	70	50
280	165	160
400		

13. Measure the distance for **Y** from the trigger (PS line) to the barcode scanner's laser line on the barcode (back edge of box), and enter that distance in the first box under **Y-Coord (mm)**.

Your measurements will likely differ from those shown below.

X-Coord (mm)	Y-Coord (mm)	Z-Coord (mm)
100	70	50
280	165	160
400	120	

14. Measure the distance for **Z** from the conveyor bed to the laser line intersecting the barcode, and enter that distance in the first box under **Z-Coord (mm)**.

Your measurements will likely differ from those shown below.

X-Coord (mm)	Y-Coord (mm)	Z-Coord (mm)
100	70	50
280	165	160
400	120	80

15. Click Calibrate 3. PackTrack data is displayed for the third code.

**PackTrack Calibration**

Code 3 - X/Y/Z: 400.000000 / 120.000000 / 80.000000  
 (Leg 1) Dist/Angle: 930.525000 / -0.181289

X-Coord (mm)	Y-Coord (mm)	Z-Coord (mm)
100	70	0
280	165	160
400	120	80

16. Click Compute Results. The results are displayed at the top of the **PackTrack Calibration** window.

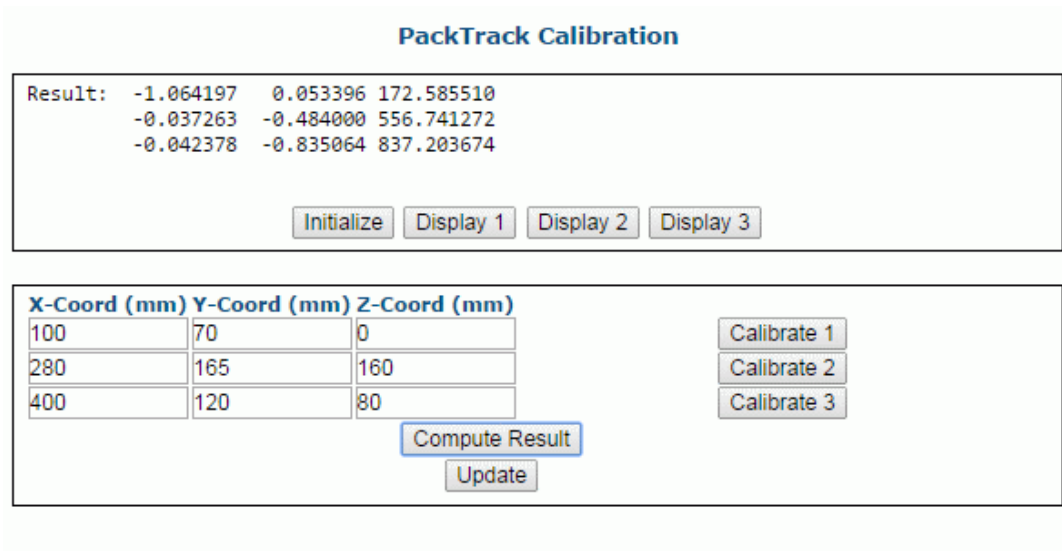

- 17. Click **Update**. "Update Successful" should be displayed in the **PackTrack Calibration** window.
- 18. Close the PackTrack Calibration Wizard window. PackTrack Calibration Coefficients have been populated on the Scanner Mounting widow.

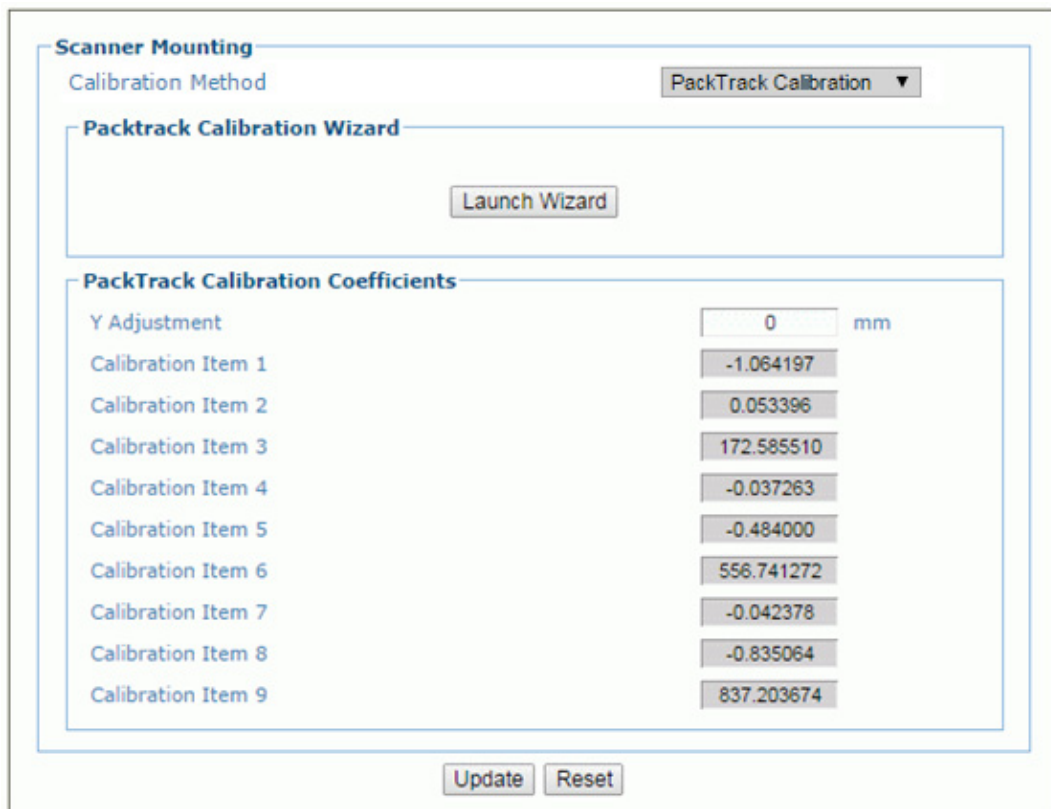

- 19. When you have finished making changes, click **Update All** to save all pending changes, click **Reset All** to revert to all previously saved values, and click **Reset Page** to revert to previous saved values on the current page.
- 20. See **Verifying PackTrack Calibration** below.

## Bottom-Mounted Barcode Scanner Calibration Using PackTrack

When using the PackTrack wizard to calibrate a bottom read scanner, three barcode positions are still needed for accurate calibration. For the left and right sides of the conveyor, place a barcode label face-down, overhanging the corner of a typical box for your application, as shown below. Place another barcode label on the bottom of a box and place the code along the laser beam in the center of the conveyor bed, as shown in the illustration below.

1. Left side, label face-down overhanging top of box
2. Centered on conveyor bed on bottom of box
3. Right side, label face-down overhanging top of box

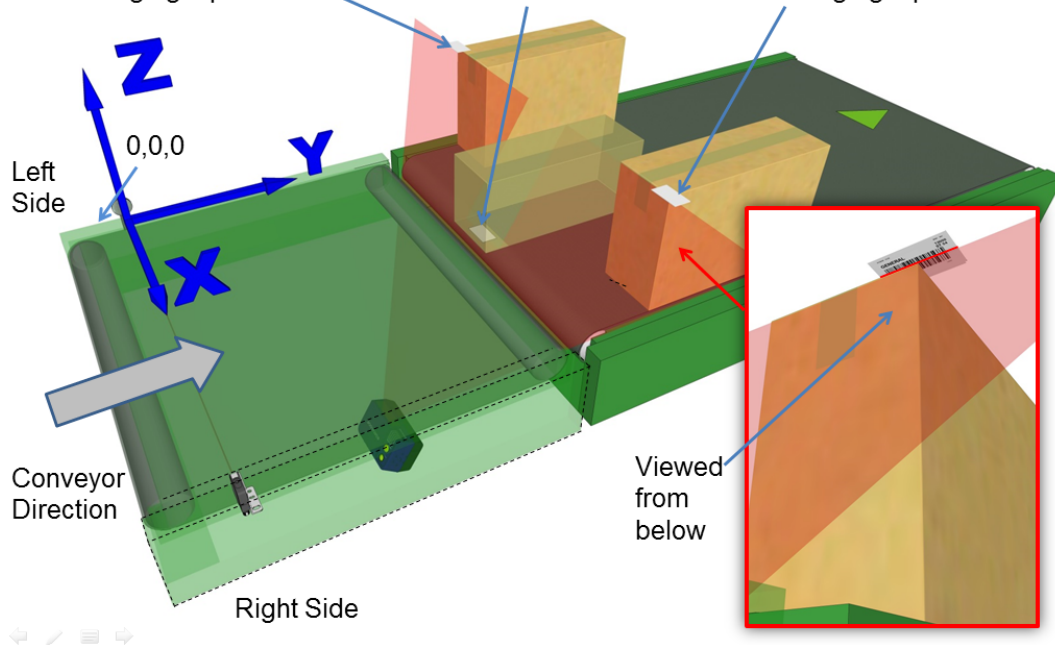

As with the top and side-read examples in this section, input the X, Y, and Z coordinates for each code in the PackTrack wizard.

## Verifying PackTrack Calibration

1. In the menu tree, navigate to **Diagnostics/Read Test**. The **Read Test** window opens.

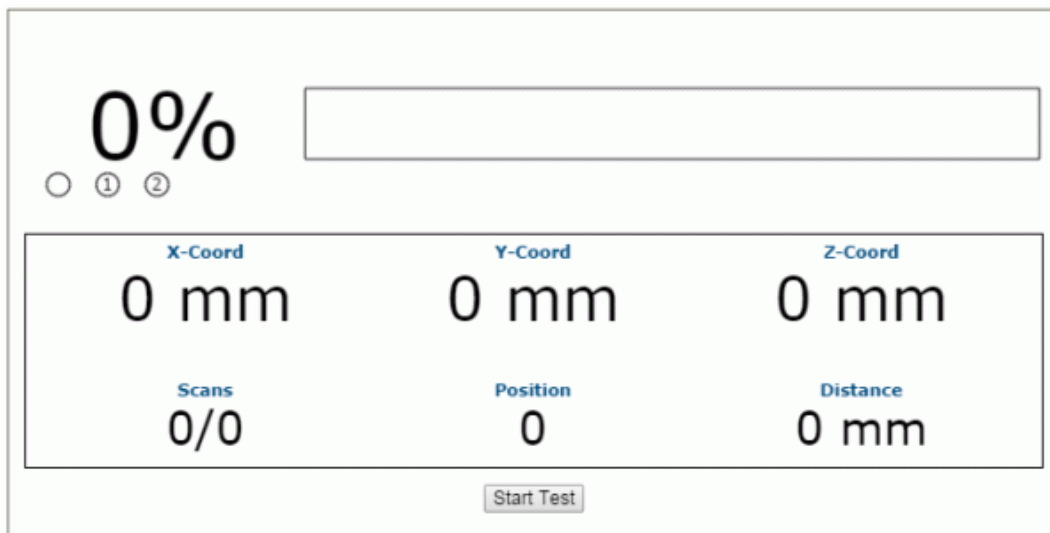

2. Place a barcode anywhere in the scanner's laser beam other than where you placed the labels for calibration.
3. Click Start Test. The system runs a test to identify the location of the barcode within the read area and displays the results in the Read Test window.

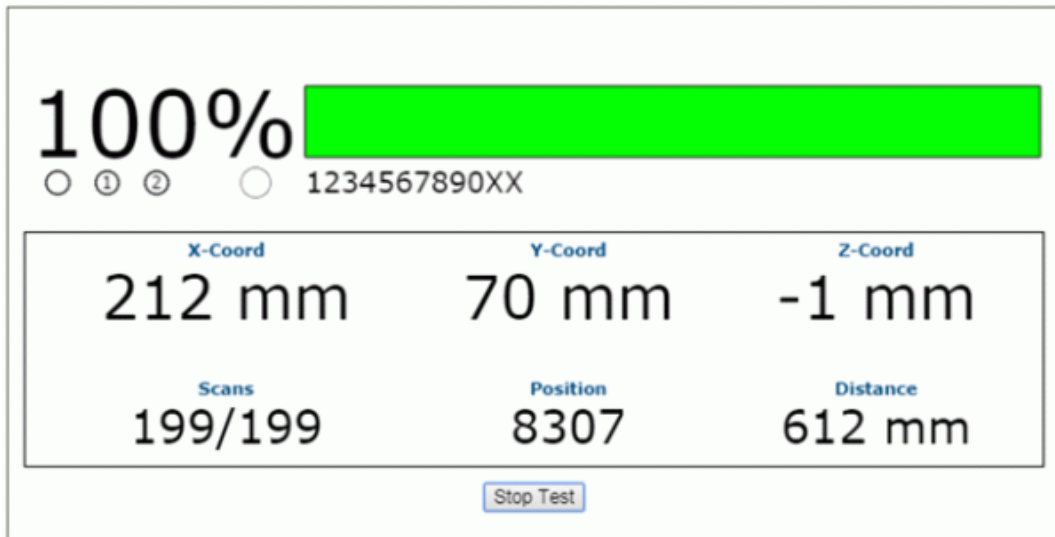

4. Physically Measure the X (from left edge), Y (From PS), and Z (code height) coordinates of your test barcode, and compare your measured results to the Read Test results. Your measured results and those displayed should be close (within a few millimeters) but do not need to be exact.

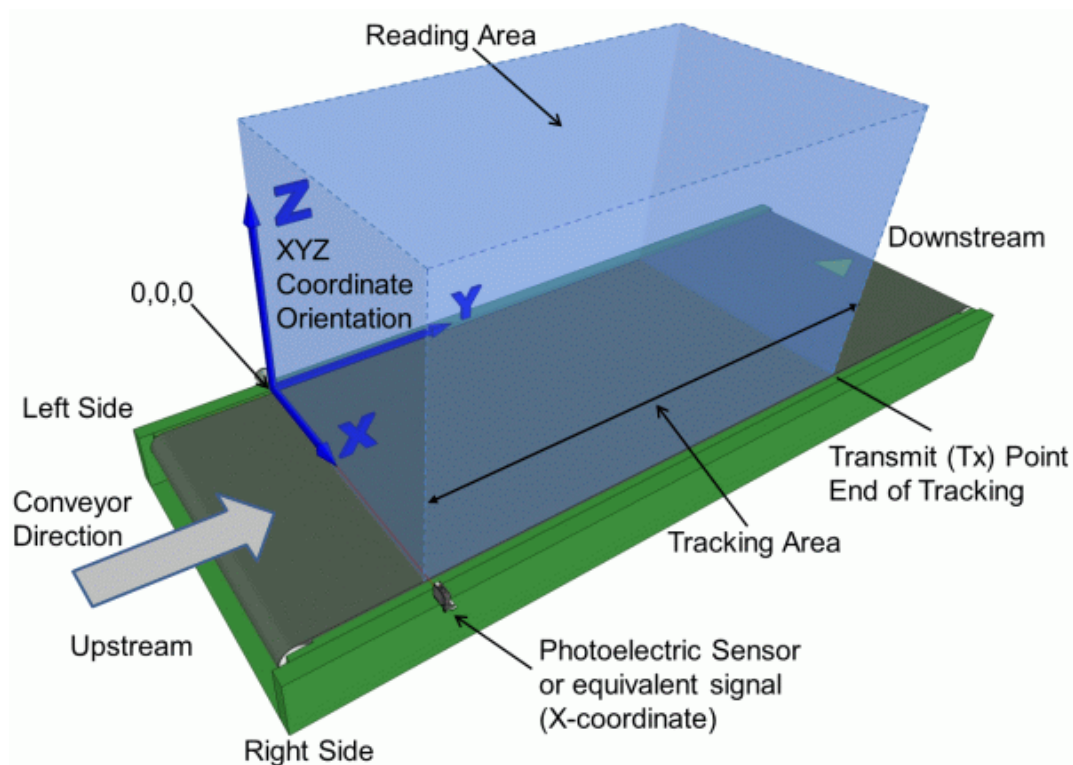

5. Next, in the menu tree, navigate to **Diagnostics/Monitor**.
6. Turn on conveyor, run a box with a readable barcode past the barcode scanner.
7. Check the Monitor to make sure the barcode on the box is being read. If you see a no read (the barcode doesn't read on the box), double check your physical measurements you entered in the PackTrack Calibration Wizard, and enter them again.

Status		Barcode Information	
<input checked="" type="checkbox"/> Phase/Trigger	<input type="checkbox"/> Output 1	Code Distance	1158 mm
<input checked="" type="checkbox"/> Good/No Read	<input type="checkbox"/> Output 2	Scan Position:	8220
<input type="checkbox"/> Multiple			<input type="checkbox"/> Near
<input type="checkbox"/> Partial			<input checked="" type="checkbox"/> Far
Belt Speed: 0.716 m/s			
Messages		Read Rate	
Tx:149780 DS8110-DX8210 - Dev:0		Package Count	149782
Tx:149780 Code128-54321 - Dev:0		Good Read (%)	0.00%
Tx:149780 1234567891231 - Dev:0		Multiple (%)	0.00%
Tx:149781 <PARTIAL> - Encoder Start/End:99751148/99751591		Partial (%)	100%
Placed Label (149785): 3219876543215 - Dev:0 Laser:2 - Adj Enc:99754843		No Read (%)	0.00%
Tx:149781 689888883292 - Dev:0		<input type="button" value="Reset"/>	
Tx:149781 3219876543215 - Dev:0			
Tx:149781 <PARTIAL> - Encoder Start/End:99751807/99752273			
Placed Label (149786): 123456789128 - Dev:0 Laser:2 - Adj Enc:99755440			
Message Monitor			
<pre>&lt;ESC&gt;[&lt;SB1&gt;&lt;VT&gt;&lt;NUL&gt;&lt;NUL&gt;&lt;NUL&gt;&lt;SOH&gt;R &lt;STX&gt;/C 128-689888883292/?????????/CR&gt;&lt;LF&gt; &lt;STX&gt;/C 128-101674471304/?????????/CR&gt;&lt;LF&gt; &lt;STX&gt;/C 128-Code128-09876/?????????/CR&gt;&lt;LF&gt; &lt;STX&gt;/#####/C 128-Code128-54321/CR&gt;&lt;LF&gt; &lt;STX&gt;/C 128-689888883292/?????????/CR&gt;&lt;LF&gt;</pre>			
<input type="radio"/> None <input type="radio"/> Main <input checked="" type="radio"/> Aux <input type="radio"/> Socket 1 <input type="radio"/> Socket 2 <input type="radio"/> Socket 3 <input type="radio"/> Socket 4 <input type="radio"/> Socket 5 <input type="radio"/> Socket 6			
<input type="button" value="Connect"/>		<input type="button" value="Disconnect"/>	

## Replacing an Installed DS8110

If for any reason, a scanner fails, it can be replaced quickly with a spare unit with parameters recovered from flash memory or a saved parameter file.



This procedure assumes that system parameters have been properly saved as described in sections , and .



If you are not sure the replacement scanner has been defaulted to factory settings, it is a good idea to default the unit before installing it in a system. To do this:

1. Attach a power cable to the replacement scanner and apply power.
2. Simultaneously, press and hold down the yellow X-Press and Restore buttons on the unit until the LEDs flash three times.
3. Release the buttons. The unit is now reset to the factory default.

If laser placement is critical (such as in Packtrack applications with tight package spacing), the laser location must be marked on the conveyor prior to the replacement, and these marks must be used to align the replacement unit.

## Replacing a Standalone Scanner Using Restore

A standalone scanner (a single scanner not connected to an array/tunnel) can be replaced using the Restore button located near the LEDs on the top of the housing.



**To replace the scanner using Restore:**

1. Remove power from the existing scanner and remove the power and I/O cables.
2. Label the cables attached to ETH1 and/or ETH2 so you can easily identify where they were connected, then remove the cables.
3. Detach the existing scanner from its mounting bracket, leaving the bracket attached to the mounting structure.
4. Attach the replacement scanner to the mounting bracket.
5. Reattach the power, I/O, ETH1 and/or ETH2 cables.
6. Apply power to the system.
7. Once the scanner has booted up and the READY LED lights solid green, press and hold the RESTORE button until all of the LEDs turn on, indicating that the parameters are being restored from the CBX510's BM100 backup module.
8. Release the RESTORE button. The green READY LED should come back on.

## Replacing a Slave Scanner in an Array/Tunnel Automatically

e-Genius provides an option for automatically replacing a slave scanner in a tunnel when the system is configured. To enable this option in e-Genius, select **Modify Setting/System Info** from the e-Genius menu tree. The System Info window opens.

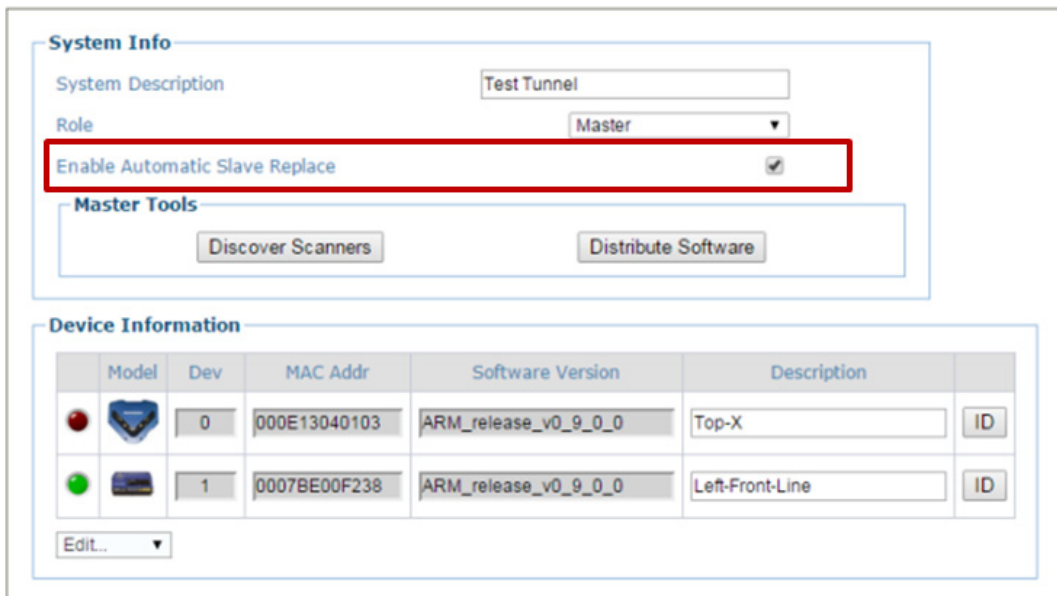

Select the **Enable Automatic Slave Replacement** check box, click **Update**, and save the system parameters as described in *sections*, and .

If the **Enable Automatic Slave Replacement** check box has been selected and saved in the system parameters, use the following procedure to replace a slave scanner:

Remove power from the array.

1. Remove the power and I/O cables from the scanner being replaced.



2. Label the cables attached to ETH1 and/or ETH2 so you can easily identify where they were connected, then remove the cables.
3. Detach the existing scanner from its mounting bracket, leaving the bracket attached to the mounting structure.
4. Attach the replacement scanner to the mounting bracket.
5. Reattach the power, I/O, ETH1 and/or ETH2 cables.
6. Apply power to the array. The system will automatically find and download system parameters to the replacement scanner.

## Replacing a Slave Scanner in an Array/Tunnel Using Restore

If the **Enable Automatic Slave Replacement** check box has NOT been selected and saved in the system parameters, use the following procedure to replace a slave scanner:

1. Remove power from the array.
2. Remove the power and I/O cables from the scanner being replaced.
3. Label the cables attached to ETH1 and/or ETH2 so you can easily identify where they were connected, then remove the cables.
4. Detach the existing scanner from its mounting bracket, leaving the bracket attached to the mounting structure.
5. Attach the replacement scanner to the mounting bracket.
6. Reattach the power, I/O, ETH1 and/or ETH2 cables.
7. Apply power to the array.
8. Once the scanner has booted up and the **READY** LED lights solid green, press and hold the **RESTORE** button until all of the LEDs turn on, indicating that the parameters are being restored from the CBX510's BM100 backup module or SC5000 flash memory.
9. Release the **RESTORE** button.

## Replacing a Master Scanner in an Array/Tunnel Using Restore

1. Remove power from the array.
2. Remove the power and I/O cables from the Master scanner being replaced.
3. Label the cables attached to ETH1 and/or ETH2 so you can easily identify where they were connected, then remove the cables.
4. Detach the existing scanner from its mounting bracket, leaving the bracket attached to the mounting structure.
5. Attach the replacement master scanner to the mounting bracket.

6. Reattach the power, I/O, ETH1 and/or ETH2 cables.
7. Apply power to the array.
8. Once the scanner has booted up and the **READY** LED lights solid green, press and hold the **RESTORE** button until all of the LEDs turn on, indicating that the parameters are being restored from the CBX510's BM100 backup module or SC5000 flash memory.
9. Release the **RESTORE** button.

## Checking the Operation of the Replacement

With the scanner replaced and your PC connected to the system, navigate to Modify Setting/System Info from the e-Genius menu tree. The System Info window opens.

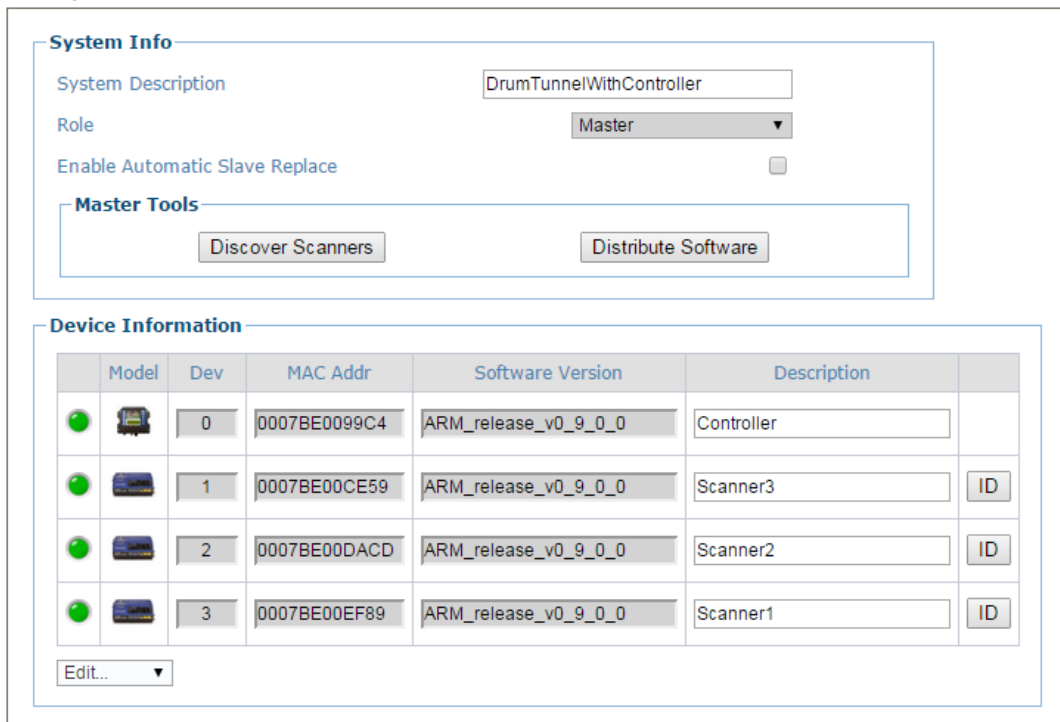

The **Device Information** section of the window should now list all of the scanners (and an SC5000 Controller if used), including the scanner you just replaced.

## Typical Layouts

The following typical layouts refer to system hardware configurations, but also require the correct setup of the software configuration parameters. Other layouts require the use of a specific SC5000 Controller model. The accessories and cables indicated in the following figures are Datalogic products. We suggest their use to guarantee the correct system functioning.



## Large Synchronized Network Layout

When building a large local EBC (Ethernet Based Connectivity) network an SC5000 Controller should be used together with a PWR-480B power supply unit. In this case the SC5000 unit acts as the system master and is connected to the host through one of its interfaces.

- The SC5000 can be connected to the Host in several different layouts depending on the controller model.
- The SC5000 Standard models provide both Ethernet connections (direct or through a Hub/Switch) and point-to-point connections on the Main interface using either RS232 or RS422 full-duplex;
- Fieldbus models, additionally provide the model specific Fieldbus: Profibus, Profinet IO, etc.
- All scanners act as slaves and are connected to the SC5000 through the EBC interface.

External devices such as a presence sensor and an encoder are all connected either to the SC5000 through its M12 circular connectors, or to the CBX510 connection box (connected to the Controller), wiring the signals through the CBX510 compression connectors.

### SC5000: Basic Layout: Ethernet TCP/IP To Host

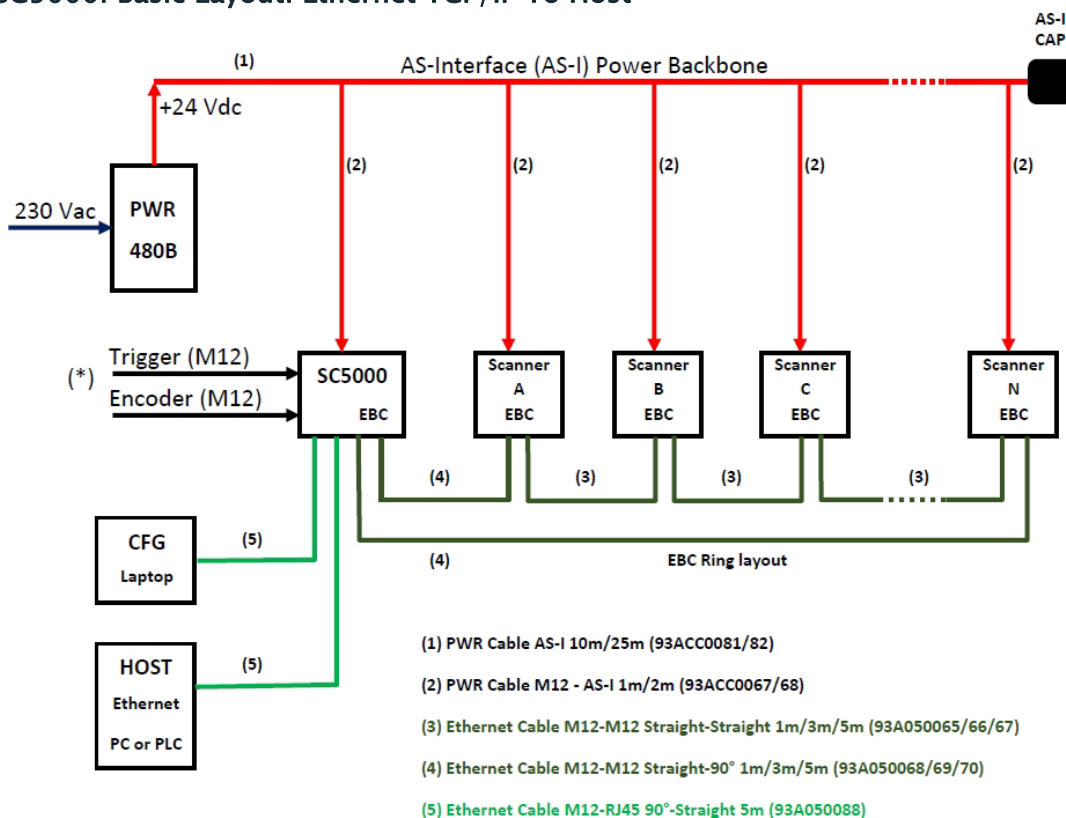

(\*)If you prefer an alternative wiring connection, rather than the M12 connection type, use the CBX510 accessory, as shown below.

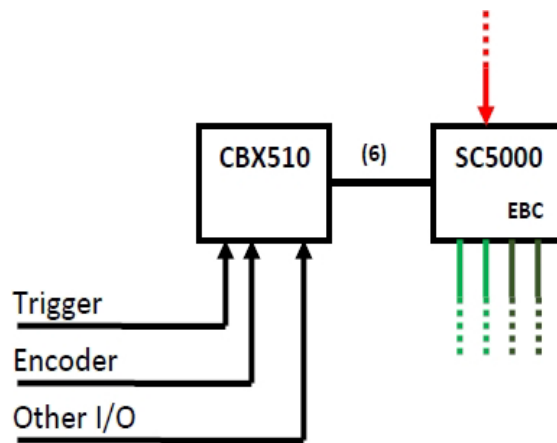

(6) CAB SC5000 TO CBX510 (93A050071)

### SC5000: Basic Layout: COM To Host

If the Host supports a COM communication type (RS232 or RS422) rather than the Ethernet one, use the CBX510 accessory, as shown below.

The remaining part of the layout (scanners, PWR etc.) does not change.

As already mentioned, the CBX510 can also be used to wire the Trigger and Encoder signals (and other I/O) as an alternative to the M12 connection.

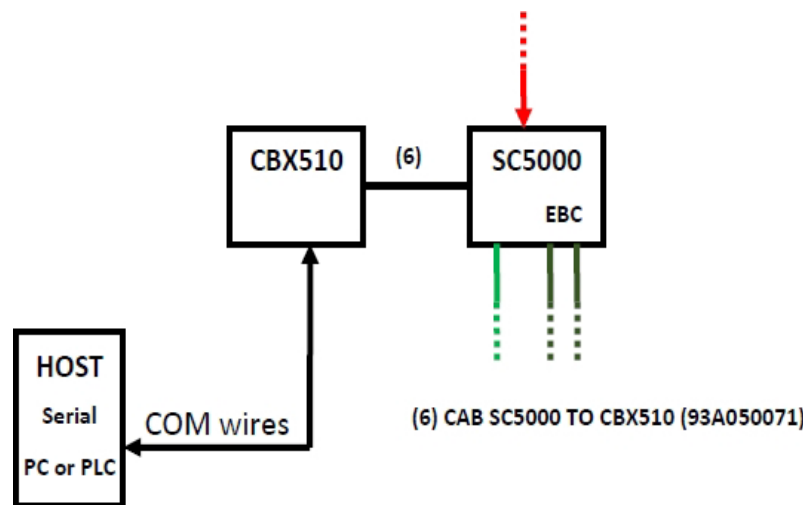

(6) CAB SC5000 TO CBX510 (93A050071)

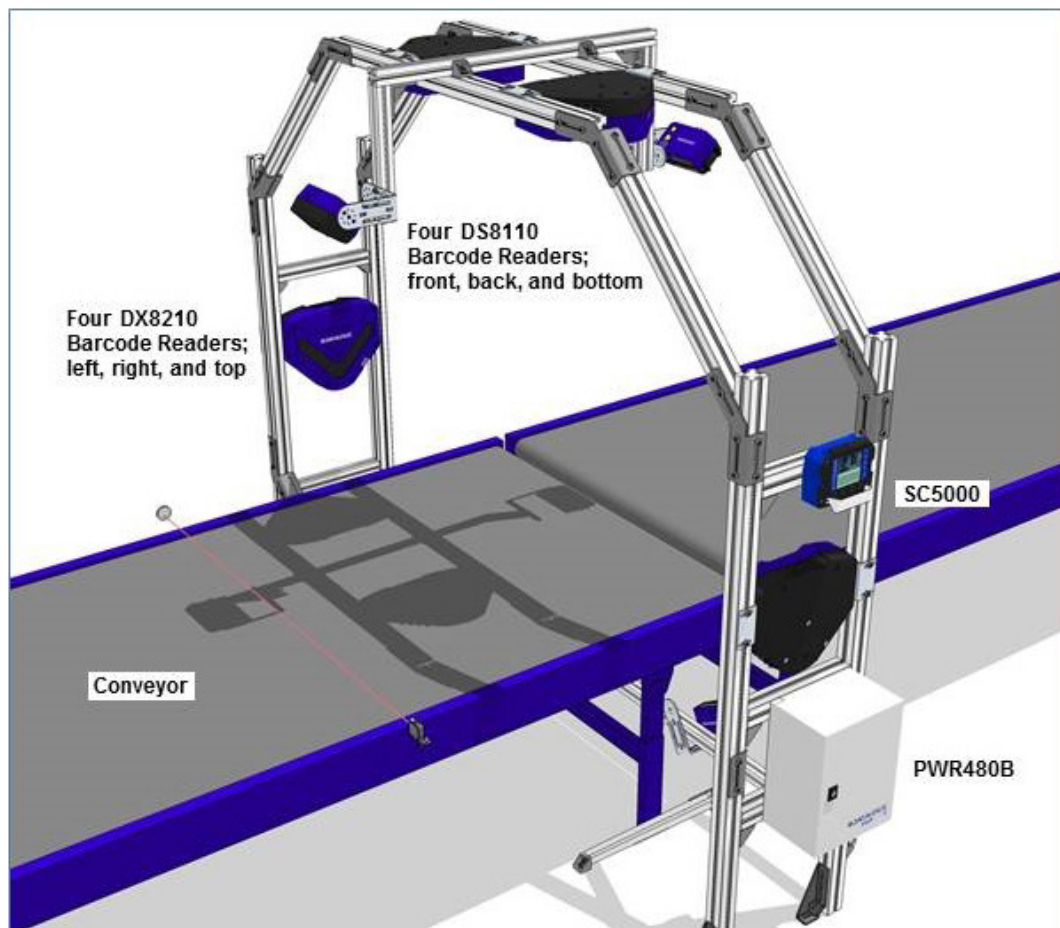

For applications having regular shaped packs, the default settings are sufficient, but for Airport applications working in PackTrack Operating Mode, irregular shaped packs can cause PS signal glitches resulting in false "packs too short" or "packs too close" errors.

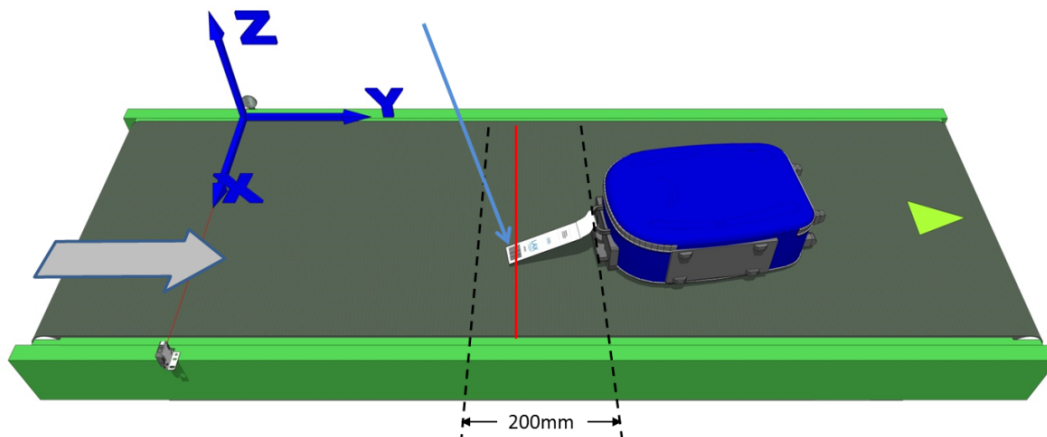

To correct this, set the following Operating Modes parameters: Minimum Distance Between Packs = 200 mm, Minimum Pack Length = 200 mm, Window Dimension = 200 mm.

## Advanced Code Reconstruction (ACR™)

The traditional way of barcode reading could be called “Linear Reading”. In this case, the laser beam crosses the barcode symbol from its beginning to its end as shown in the following figure:

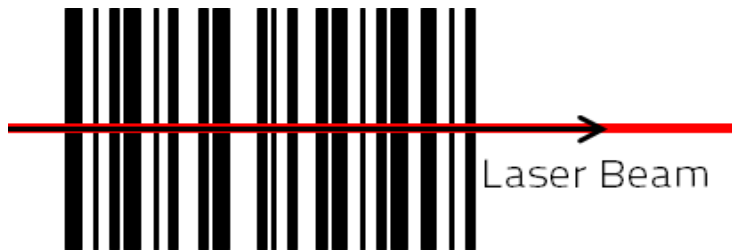

In Advanced Code Reconstruction mode it is no longer necessary for the laser beam to cross the label from the start to the end. With just a set of partial scans on the label (obtained using the motion of the label itself), the DS8110 is able to “reconstruct” the barcode. A typical set of partial scans is shown in the figure below:

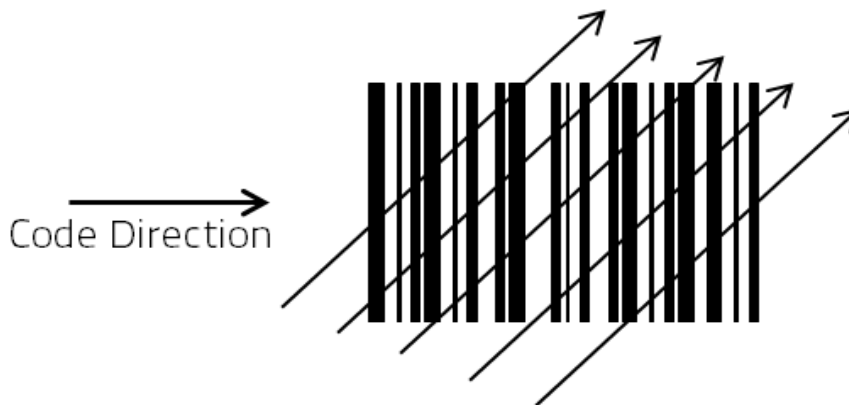

None of the partial scans contains the whole label. The decoder aligns each partial scan correctly and combines them in order to obtain the entire code.

The alignment is performed by calculating the time difference from one partial scan to another using a reference code element.

## Tilt Angle for Advanced Code Reconstruction

The most important parameter in Advanced Code Reconstruction is the value of the maximum tilt angle ( $\alpha$  maximum) under which the code reconstruction process is still possible.

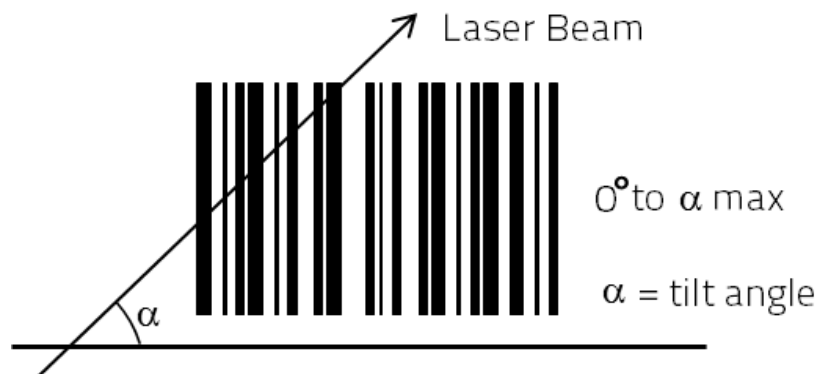

The decoder will be able to read the label with a tilt angle between  $+\alpha$  max and  $-\alpha$  max as shown in the following figure:

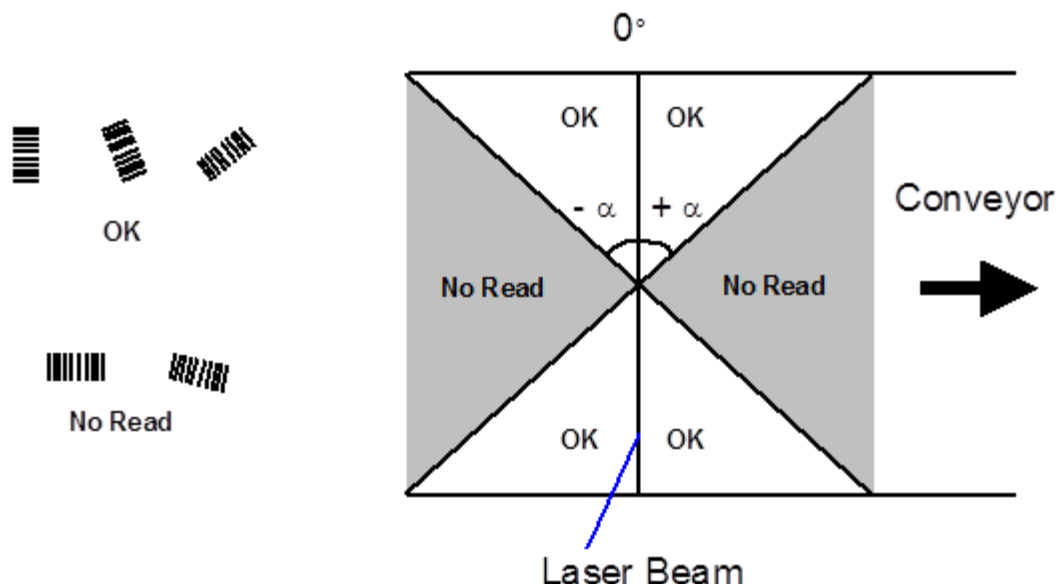

The formulas to calculate a maximum depend on various parameters such as: label height, number of scans per second, code motion speed, etc. Minimum label heights at different conveyor speeds are given in the tables in section , depending on standard a values of 45° and 30°.

### Minimum Code Height for Advanced Code Reconstruction

Based on the scanner read rate of 1000 scans/sec., minimum label heights at different conveyor speeds are given in the tables below.

Refer to the reading diagrams in *section* for further details on the reading features. These diagrams are taken on various resolution sample codes at a 25 °C ambient temperature depending on the conditions listed under each diagram.

- ANSI Grade B minimum
- 1000 scans/sec

The following tables describe the requirements for standard applications.

		Minimum Code Height for ACR Reading (mm)											
		45°						30°					
Conveyor Speed (m/s)		0.5	1	1.5	2	2.5	3	0.5	1	1.5	2	2.5	3
2/5 Interleaved Code Resolution (mm)	0.25	10	11	13	14	16	17	7	8	9	10	12	13
	0.30	12	13	14	16	17	19	8	9	10	11	12	14
	0.33	12	14	15	17	18	20	8	9	10	12	13	14
	0.38	14	15	16	18	19	21	9	10	11	12	14	15
	0.50	18	18	20	21	23	24	11	12	13	14	15	17
	0.72	24	25	26	27	28	30	15	16	16	18	19	20
	1.00	33	33	34	35	36	37	20	20	21	22	23	24

Ratio 3:1

		Minimum Code Height for ACR Reading (mm)											
		45°					30°						
Conveyor Speed (m/s)		0.5	1	1.5	2	2.5	3	0.5	1	1.5	2	2.5	3
<b>Code 39 Code Resolution (mm)</b>	0.25	9	9	11	12	14	15	6	7	8	9	10	11
	0.30	10	11	12	13	15	16	7	7	8	10	11	12
	0.33	11	11	12	14	15	17	7	8	9	10	11	12
	0.38	12	13	13	15	16	18	8	8	9	10	12	13
	0.50	15	16	16	17	18	20	9	10	11	12	13	14
	0.72	20	21	22	22	23	24	13	13	14	14	15	16
	1.00	27	28	29	29	30	31	17	17	18	18	19	20

Ratio 3:1; Interdigit = Module Size

		Minimum Code Height for ACR Reading (mm)											
		45°					30°						
Conveyor Speed (m/s)		0.5	1	1.5	2	2.5	3	0.5	1	1.5	2	2.5	3
<b>Code 128 – GS1-128 Code Resolution (mm)</b>	0.25	7	9	10	12	13	15	6	6	8	9	10	11
	0.30	8	9	11	12	14	15	6	7	8	9	10	12
	0.33	9	10	11	13	14	16	6	7	8	9	11	12
	0.38	10	11	12	14	15	17	6	8	9	10	11	12
	0.50	12	13	14	16	17	19	8	9	10	11	12	13
	0.72	16	17	18	19	21	22	10	11	12	13	14	15
	1.00	21	22	23	24	25	26	13	14	15	16	17	18

Ratio 3:1; Interdigit = Module Size

		Minimum Code Height for ACR Reading (mm)											
		45°					30°						
Conveyor Speed (m/s)		0.5	1	1.5	2	2.5	3	0.5	1	1.5	2	2.5	3
<b>Codabar Code Resolution (mm)</b>	0.25	8	9	10	12	13	15	5	6	8	9	10	11
	0.30	9	9	11	12	14	15	6	7	8	9	10	12
	0.33	9	10	11	13	14	16	6	7	8	9	11	12
	0.38	10	11	12	14	15	17	7	8	9	10	11	12
	0.50	13	13	14	16	17	19	8	9	10	11	12	13
	0.72	17	18	18	19	21	22	11	11	12	13	14	15
	1.00	23	23	24	25	26	26	14	15	15	16	17	18

		Minimum Code Height for ACR Reading (mm)											
		45°					30°						
Conveyor Speed (m/s)		0.5	1	1.5	2	2.5	3	0.5	1	1.5	2	2.5	3
EAN 8-13, UPC-A Code Resolution (mm)	0.25	7	8	9	11	12	14	5	6	7	8	9	11
	0.30	8	9	10	11	13	14	6	6	7	9	10	11
	0.33	9	10	10	12	13	15	6	7	8	9	10	11
	0.38	10	11	11	12	14	15	6	7	8	9	10	12
	0.50	12	13	14	14	15	17	8	8	9	10	11	12
	0.72	16	17	18	18	19	20	10	11	11	12	13	14
	1.00	21	22	23	24	24	25	13	14	15	15	16	16

## Reading Diagram

How to identify the scanner model:  
The model type is shown on the serial label.



- DS8110-2100 is **Standard Resolution**
- DS8110-2200 is **High Resolution**
- DS8110-2300 is **Low Resolution**

DS8110-2100 – Standard Resolution

DS8110-2100 Model 1

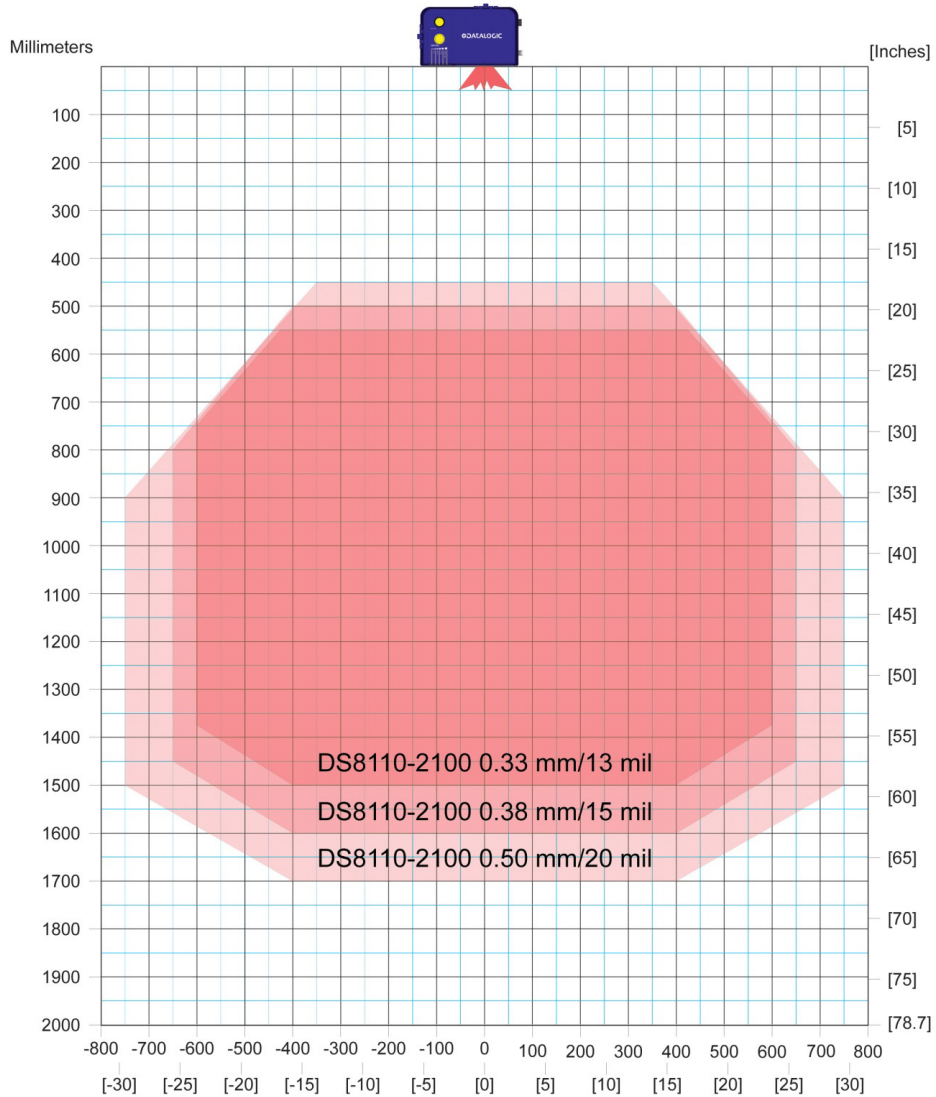

1,000 scans per second (standard) throughout DOF  
ANSI Contrast Grade 84% or greater  
ANSI "Grade A" Print Quality

Pitch not greater than +/- 15 °  
Skew not greater than +/- 15 °  
Tilt not greater than +/- 45 °



DS8110-2100 0.33mm/13mil

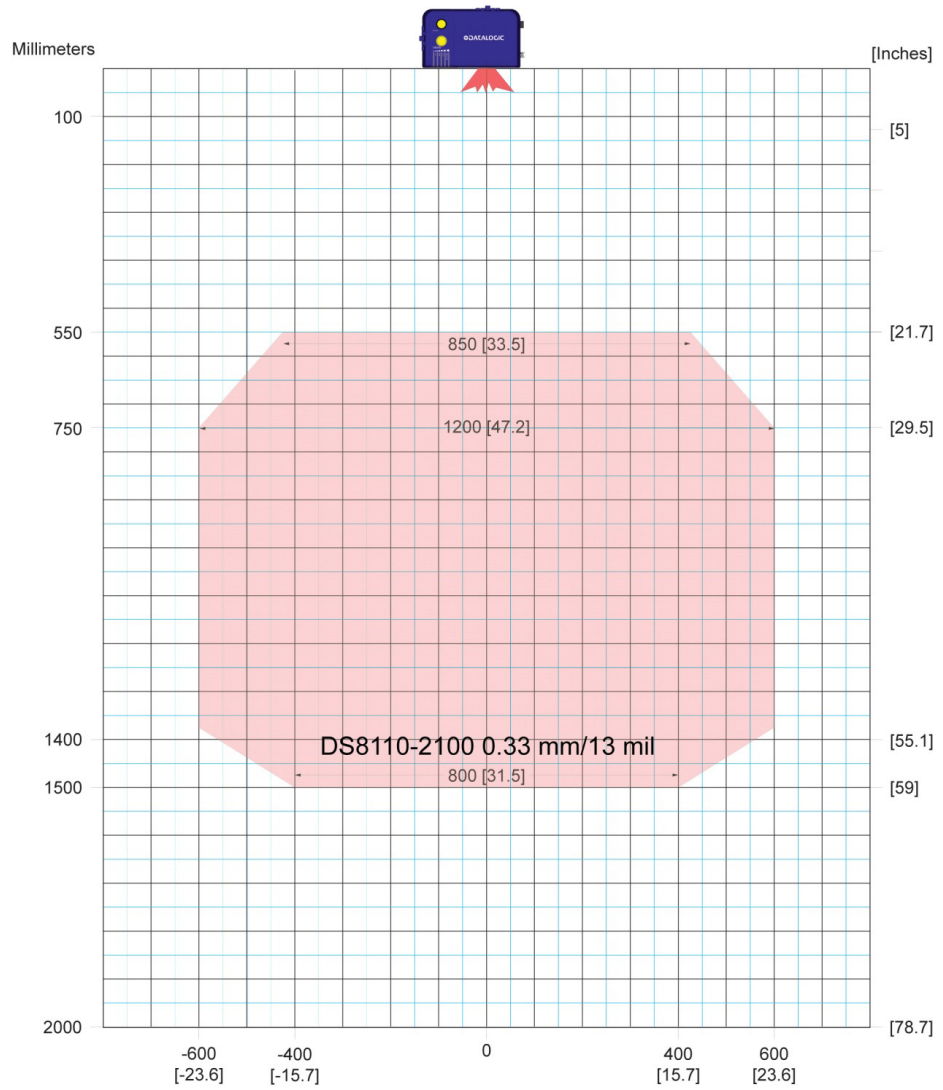

1,000 scans per second (standard) throughout DOF  
 ANSI Contrast Grade 84% or greater  
 ANSI "Grade A" Print Quality

Pitch not greater than +/- 15 °  
 Skew not greater than +/- 15 °  
 Tilt not greater than +/- 45 °

### DS8110-2100 0.38mm/15mil

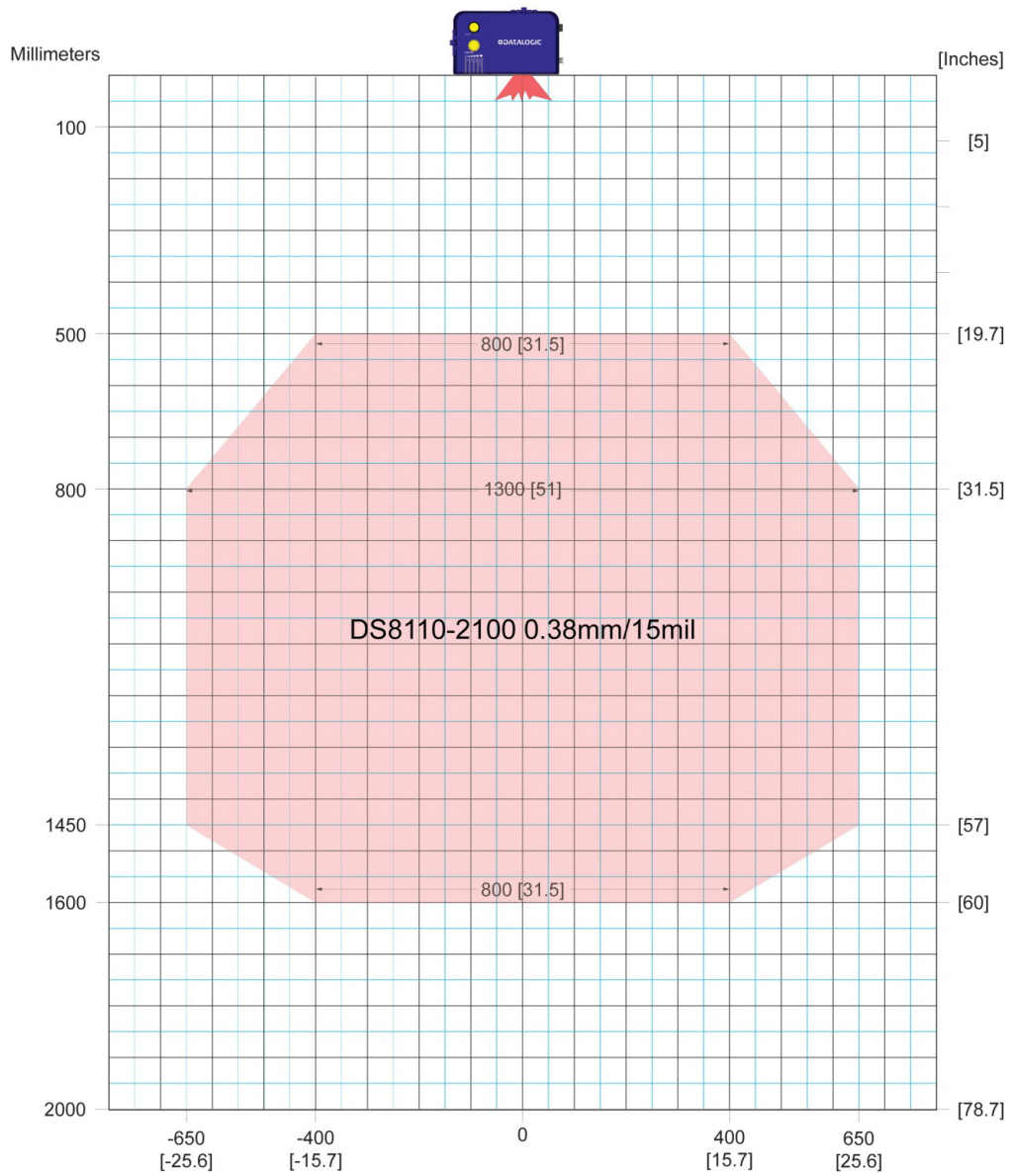

1,000 scans per second (standard) throughout DOF  
 ANSI Contrast Grade 84% or greater  
 ANSI "Grade A" Print Quality

Pitch not greater than +/- 15 °  
 Skew not greater than +/- 15 °  
 Tilt not greater than +/- 45 °

### DS8110-2100 0.50mm/20mil

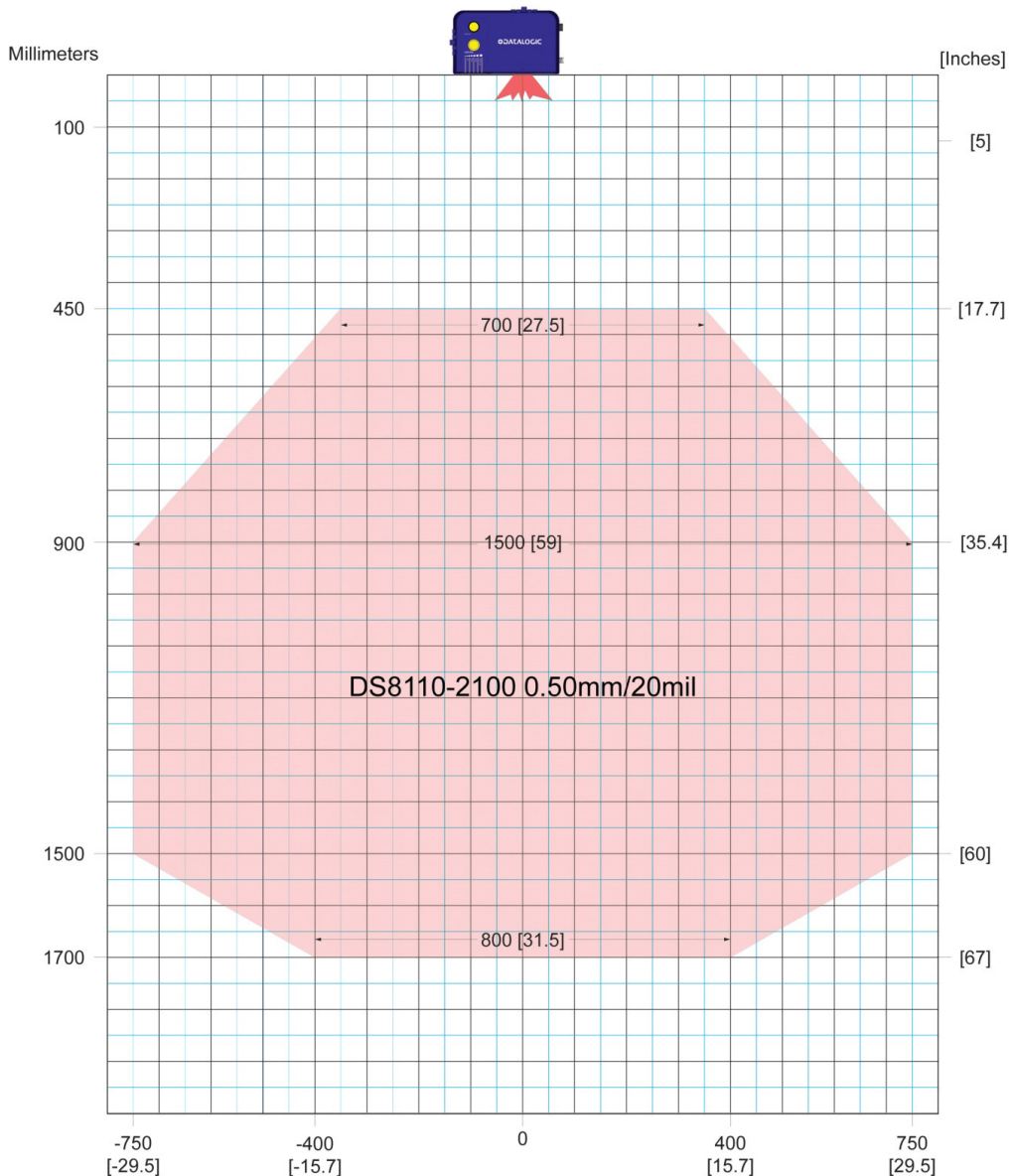

1,000 scans per second (standard) throughout DOF  
 ANSI Contrast Grade 84% or greater  
 ANSI "Grade A" Print Quality

Pitch not greater than +/- 15 °  
 Skew not greater than +/- 15 °  
 Tilt not greater than +/- 45 °

High Resolution

DS8110-2200 Model 2

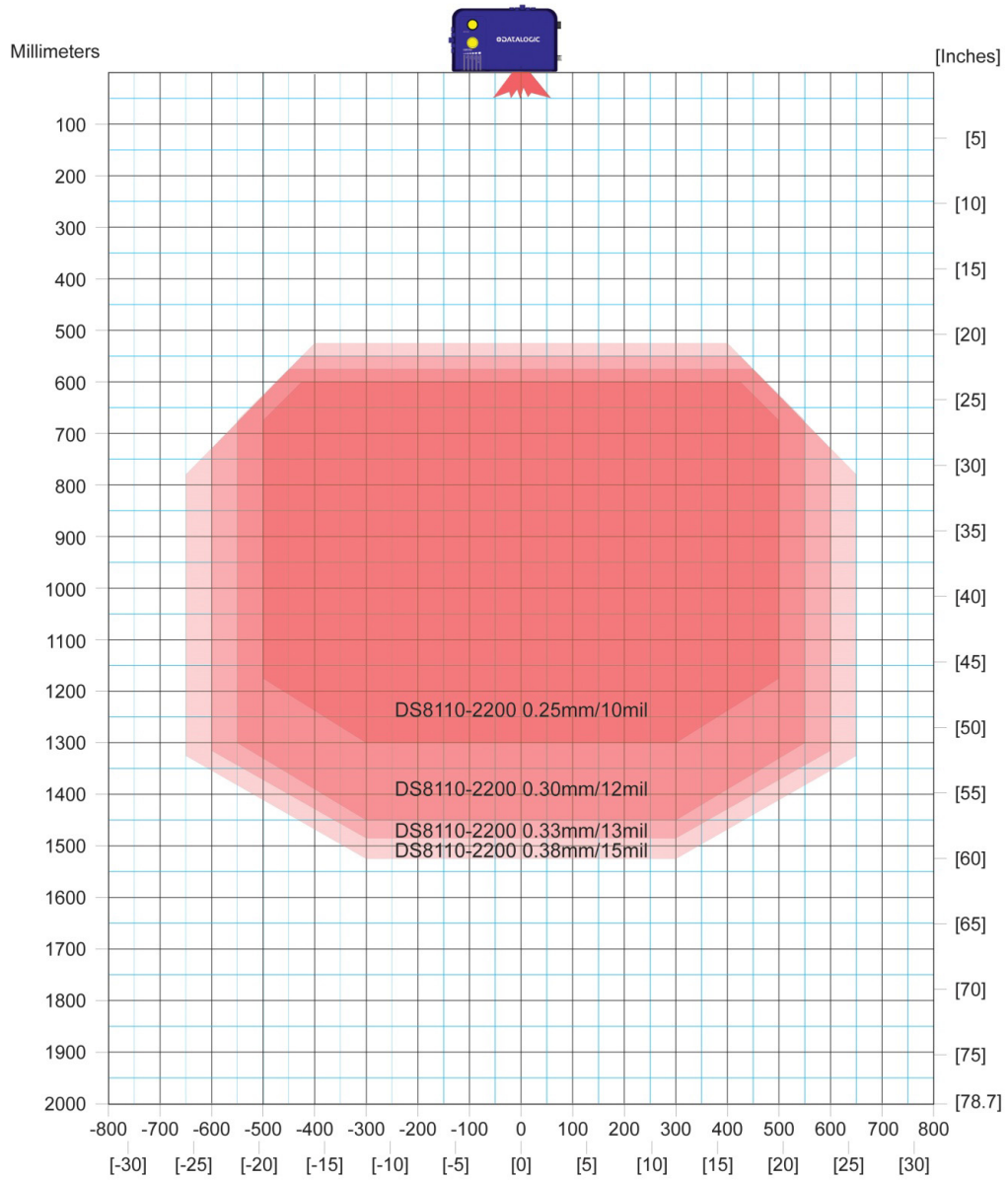

1,000 scans per second (standard) throughout DOF  
ANSI Contrast Grade 84% or greater  
ANSI "Grade A" Print Quality

Pitch not greater than +/- 15 °  
Skew not greater than +/- 15 °  
Tilt not greater than +/- 45 °

### DS8110-2200 0.25mm/10mil

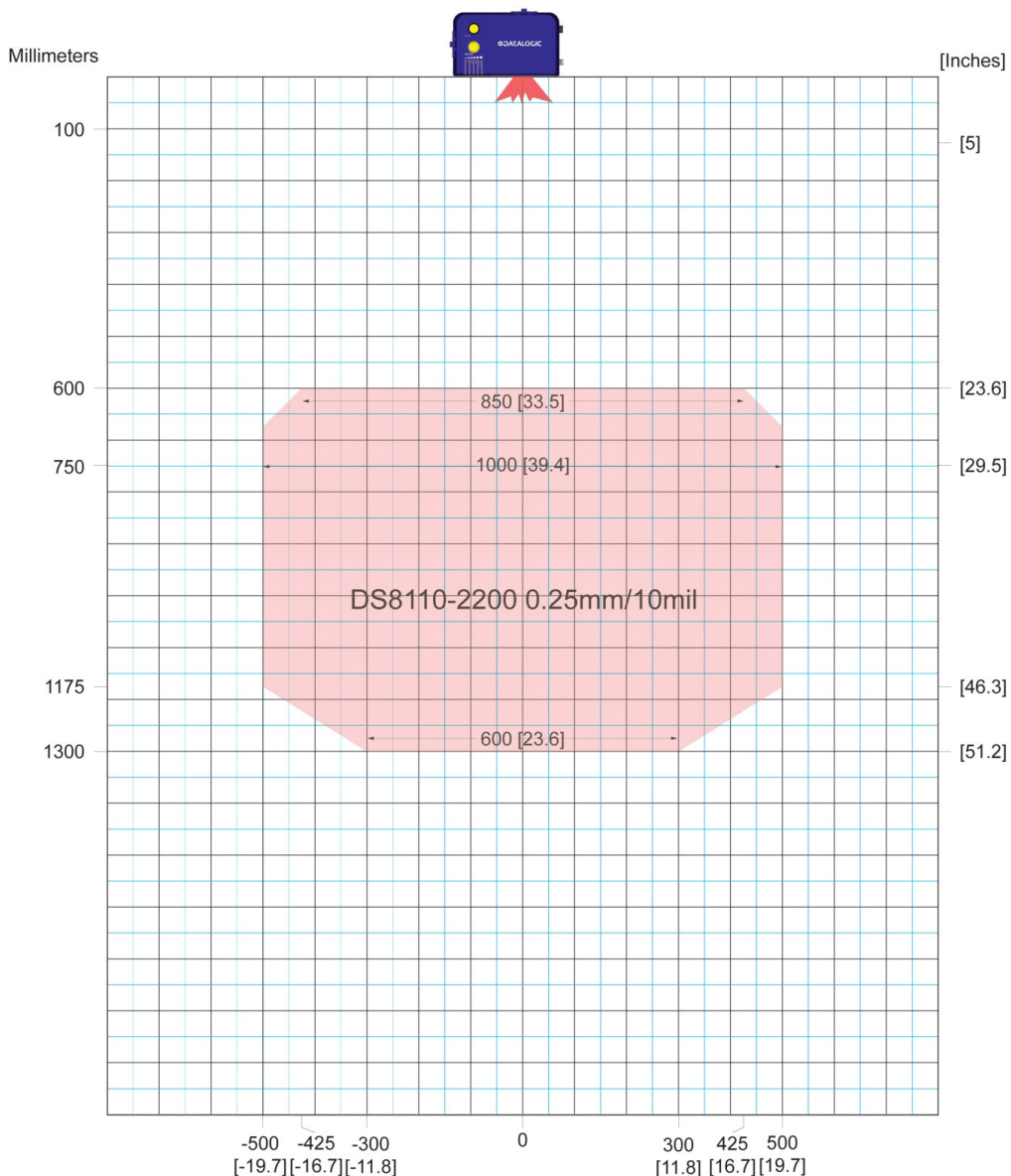

1,000 scans per second (standard) throughout DOF  
 ANSI Contrast Grade 84% or greater  
 ANSI "Grade A" Print Quality

Pitch not greater than +/- 15 °  
 Skew not greater than +/- 15 °  
 Tilt not greater than +/- 45 °

### DS8110-2200 0.30mm/12mil

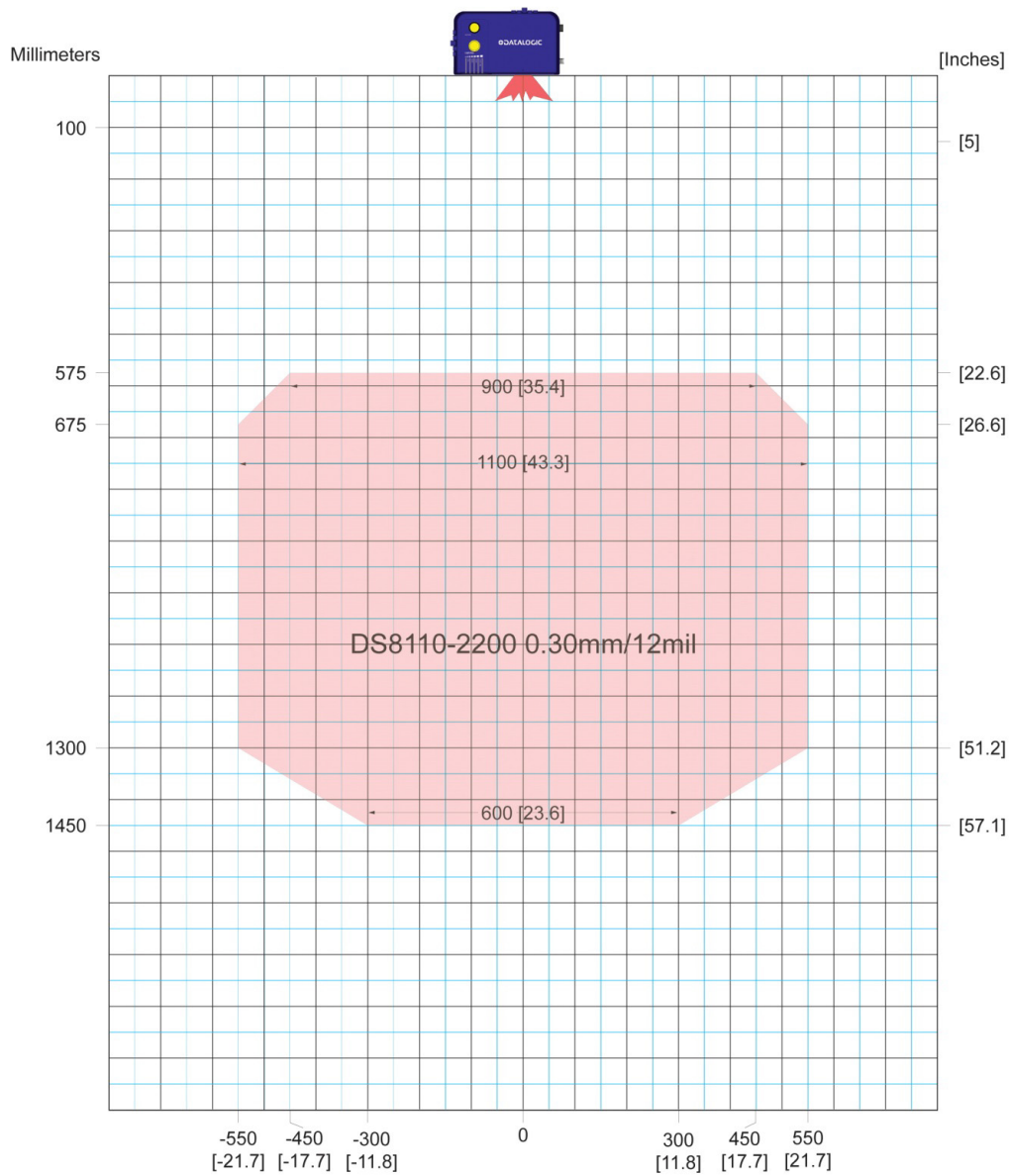

1,000 scans per second (standard) throughout DOF  
 ANSI Contrast Grade 84% or greater  
 ANSI "Grade A" Print Quality

Pitch not greater than +/- 15 °  
 Skew not greater than +/- 15 °  
 Tilt not greater than +/- 45 °



### DS8110-2200 0.33mm/13mil

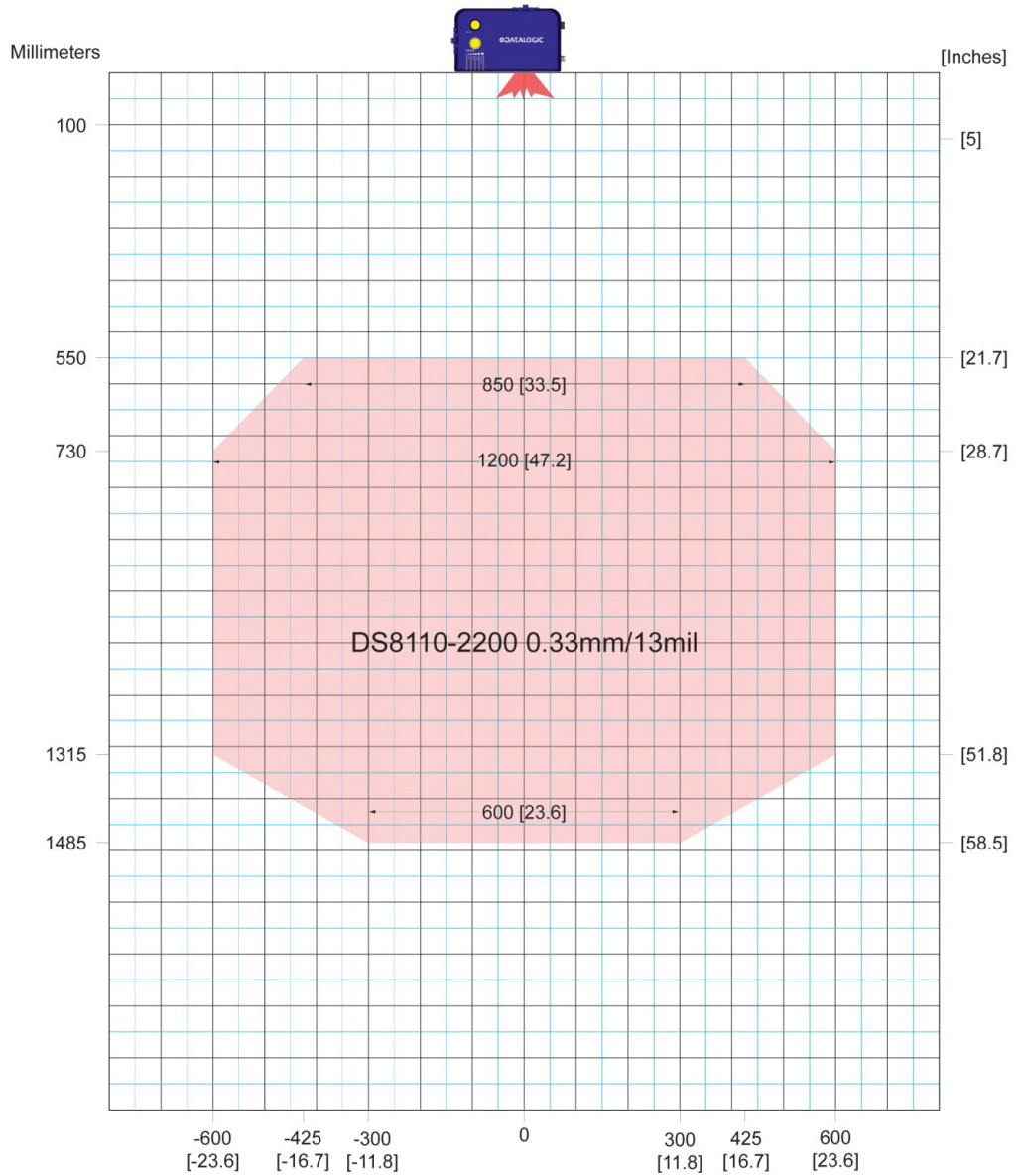

1,000 scans per second (standard) throughout DOF  
 ANSI Contrast Grade 84% or greater  
 ANSI "Grade A" Print Quality

Pitch not greater than +/- 15 °  
 Skew not greater than +/- 15 °  
 Tilt not greater than +/- 45 °

### DS8110-2200 0.38mm/15mil

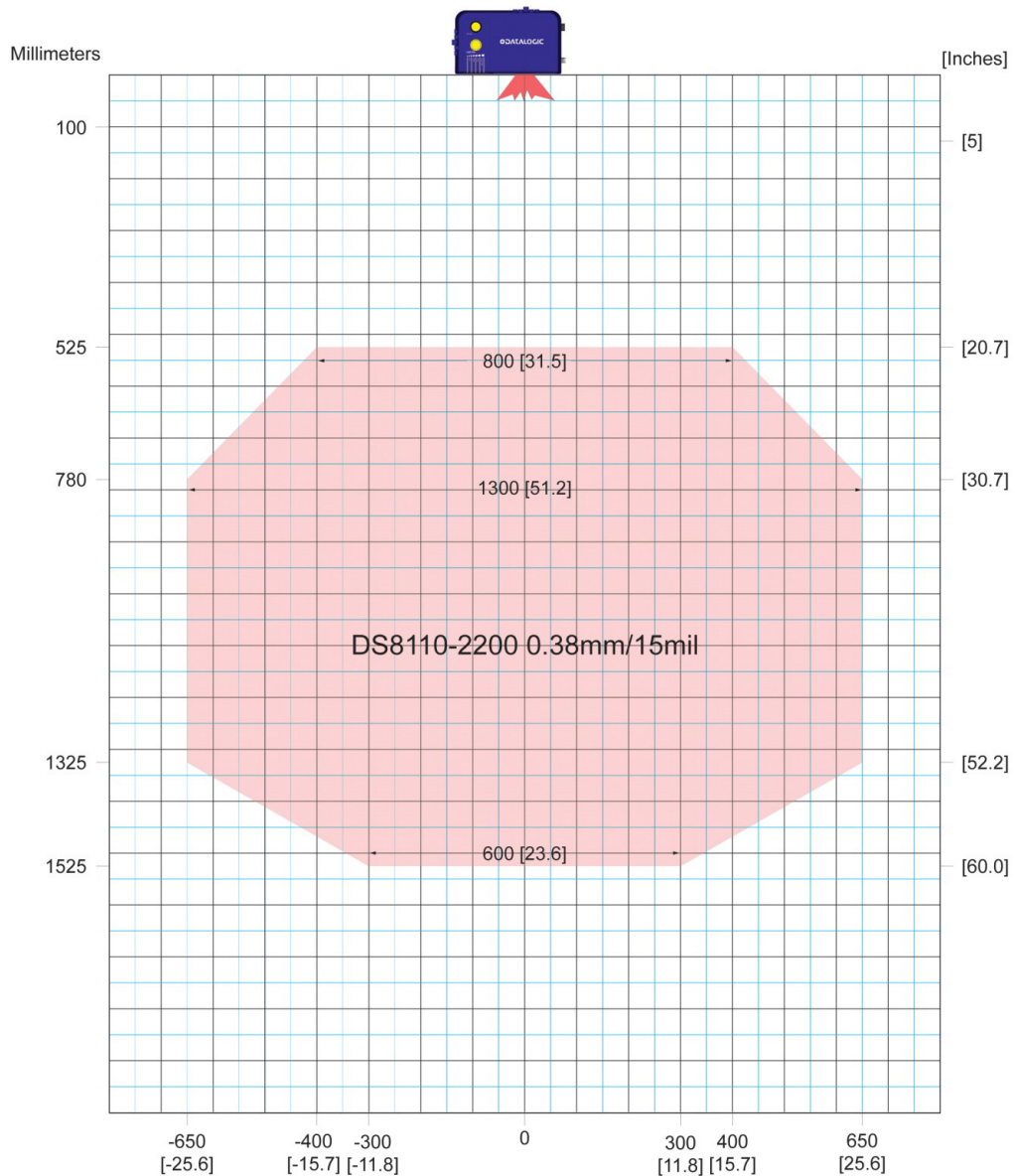

1,000 scans per second (standard) throughout DOF  
 ANSI Contrast Grade 84% or greater  
 ANSI "Grade A" Print Quality

Pitch not greater than +/- 15 °  
 Skew not greater than +/- 15 °  
 Tilt not greater than +/- 45 °



DS8110-2300 0.50mm/20mil

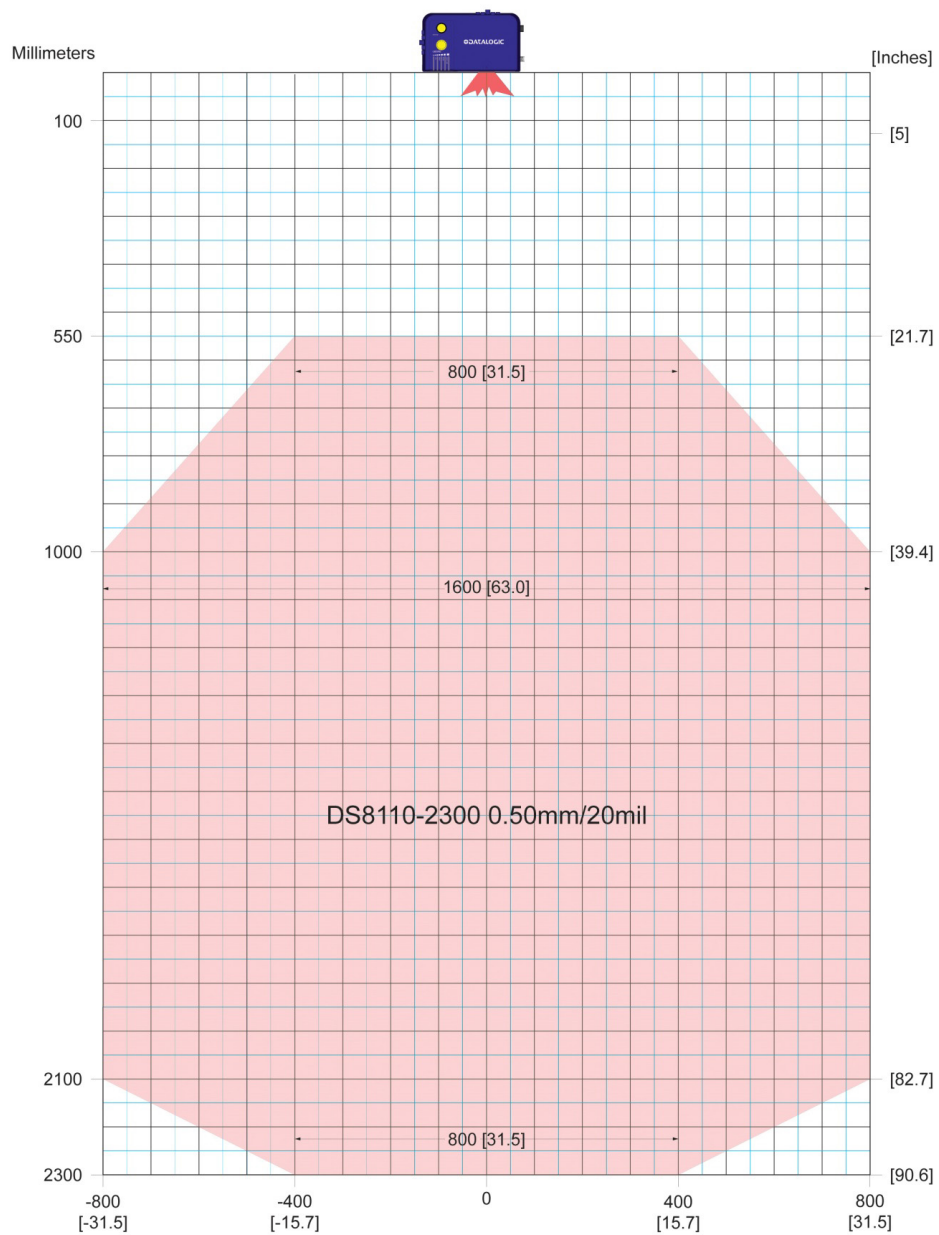

1,000 scans per second (standard) throughout DOF  
 ANSI Contrast Grade 84% or greater  
 ANSI "Grade A" Print Quality

Pitch not greater than +/- 15 °  
 Skew not greater than +/- 15 °  
 Tilt not greater than +/- 45 °



# Chapter 6 Maintenance

## Overview

This chapter provides instructions for maintaining optimum performance and life for your DS8110 barcode scanners. It provides specific information on:

- Maintenance Procedures
- Exterior Cleaning
- Mounting Hardware Checks
- Wiring Connection Checks

Item	Description
Soft-bristle brush	For cleaning the unit's exterior
Clean, soft cloths	For cleaning the unit's exterior
Cleaning solutions	Mild detergent solution for cleaning the unit's exterior.
	70% denatured alcohol, 30% de-ionized water solution for cleaning exit window
Soft cotton swabs or lint-free cloth	Use to clean barcode scanner's exit window

### WARNING



Due to the complex and application-specific nature of these installations, the barcode scanner must be setup and serviced by authorized technicians trained by Datalogic.

**THE MAINTENANCE PROCEDURES IN THIS CHAPTER MAY BE PERFORMED BY AN END USER TECHNICIAN. TRAINING IS RECOMMENDED IF THE END USER INTENDS TO DO MORE THAN THE MAINTENANCE PROCEDURES PROVIDED IN THIS CHAPTER.**

**THERE ARE NO USER SERVICEABLE PARTS WITHIN THE BARCODE SCANNER.**

**DO NOT OPEN THE UNIT. OPENING THE BARCODE SCANNER MAY VOID ITS WARRANTY.**

**CAUTION: PROCEEDING WITH ANY SETUP, CALIBRATION, OR SERVICE PROCEDURES WITHOUT PROPER TRAINING MAY VOID THE WARRANTY.**

For further information on training, contact us through our website at [www.datalogic.com](http://www.datalogic.com).

## Maintenance Tasks

Perform the maintenance tasks on an “as needed” basis to assure proper operation of the barcode scanner. Task schedule frequency depends upon the application environment conditions. It only requires a few minutes to complete each maintenance task.

### Exterior Cleaning

LASER CAUTION



Shut down the scanner before performing this maintenance task. Do not stare into the scanner’s exit window at the laser light. Avoid direct eye exposure. The laser light level does not constitute a health hazard, however staring at the laser light for prolonged periods could result in eye damage.

WARNING



Do not use any chemical on the scanner that is unsafe for plastics, such as benzene, acetone, or similar products. Before performing this maintenance task, be sure to shutdown the unit

The exterior cleaning procedure may be performed without removing the reader from the mounting structure.

1. Turn off the barcode scanner by disconnecting the power source.
2. Clean the exterior (except the exit window) with a clean, soft-bristle brush. Be sure not to brush any dust, dirt, or debris onto the exit window.
3. Carefully remove any debris in or around the exit window.
4. Wipe the exterior (except the exit window) with a clean, soft cloth dampened slightly with a mild detergent solution.
5. The exit window should be cleaned after this task is completed.

## Cleaning the Exit Window



**LASER CAUTION**



Shut down the scanner before performing this maintenance task. Do not stare into the scanner's exit window at the laser light. Avoid direct eye exposure. The laser light level does not constitute a health hazard, however staring at the laser light for prolonged periods could result in eye damage.

**WARNING**



Never apply cleaning solution directly to the exit window. Always apply the solution to a cloth, and then the cloth to the window. Do not use any chemical on the barcode scanner that is unsafe for plastics, such as benzene, acetone, or similar products.

The exit window cleaning procedure may be performed without removing the reader from the mounting structure if it is possible to do so.

1. Turn off the scanner by disconnecting the power source.
2. Follow the exterior cleaning procedure before cleaning the exit window.
3. Check the exit window surface for any dust, dirt, or smudges. If the window needs to be cleaned, proceed to Step 4.
4. Make a solution of seven parts denatured alcohol and three parts water.
5. Apply the cleaning solution to a cotton swab or lint-free cloth.
6. Apply the cleaning solution to the exit window.
7. Remove any streaks or remaining moisture from the exit window with a dry, soft, lint-free cloth or lens paper.
8. Verify scanner operation.

## Cleaning the Photoelectric Sensor

If your application uses the photoelectric sensor option as a hardware trigger, be sure to clean the photoelectric sensor periodically as outlined below.

1. Turn off the product transport.
2. Turn off the scanner by disconnecting the power source.
3. Clean the photoelectric sensor's lens using the denatured alcohol solution and a cotton swab or lens paper.
4. Clean the reflector using the denatured alcohol solution and a cotton swab or lens paper.
5. Verify photoelectric sensor operation.

## Cleaning the Tachometer

If your application uses the tachometer option for tracking purposes, be sure to clean the tachometer wheels periodically as outlined below.

1. Turn off the product transport.
2. Turn off the scanner by disconnecting the power source.
3. Using a clean, soft cloth, wipe the wheels of the tachometer clean using a mild detergent solution.
4. Before restarting the system, be sure the tachometer is making good contact with the product transport.
5. Verify tachometer operation.



## Tighten Mounting Hardware

1. Check all barcode scanner, CBX connection box(if applicable), SC5000 Controller (if applicable), and power supply mounting hardware as applicable. Tighten as necessary. Do not over-tighten. Be sure not to disturb the equipment's alignment as it relates to the product transport.
2. Check the mounting hardware of the Photoelectric Sensor (if this option is being used). Tighten as necessary. Do not over-tighten.
3. Check the mounting hardware of the tachometer (if this option is being used). Tighten as necessary. Do not over-tighten.

## Checking Barcode Scanning System Connections

Wiring connections to the barcode scanners are made between the connector panel and CBX connection box and/or SC5000 Controller. (See Chapter , Electrical Installation.)

1. Check all wiring connections to the connector panel. Tighten any loose connections as necessary. Do not over-tighten.

2. Check all wiring connections to the CBX connection box and/or SC5000 Controller. Tighten any loose connections as necessary. Do not over-tighten.
3. Check all cabling/conduit for signs of wear/damage. Repair/replace any damaged cable connections as necessary.

## Verify Barcode Scanner Operation

If after performing maintenance, the barcode scanning system continues to perform below the normal operations experienced with the system under normal daily conditions, contact Datalogic through our website at [www.datalogic.com](http://www.datalogic.com).

## Verify Photoelectric Sensor Operation

1. Block the Photoelectric Sensor emitter beam to confirm it is aligned properly with the reflector.
2. Verify that the TRIGGER LED on barcode scanner lights YELLOW when photoelectric sensor beam is blocked.
3. If the photoelectric sensor's LED does not change status, adjust the photoelectric sensor so that it is properly aligned with the reflector.
4. If the TRIGGER LED on the barcode scanner is not green when the photoelectric sensor's beam is blocked, check the cabling between the photoelectric sensor and CBX510 or SC5000 for damage.

## Verify Tachometer Operation

Rotate the tachometer wheel slowly.

The ENC/TACH LED in the CBX510 or the TACH LED on the SC5000 should flash indicating the tachometer is operational. Also, you can view the belt speed by navigating to **Diagnostics | Monitor** in e-Genius (see section ).

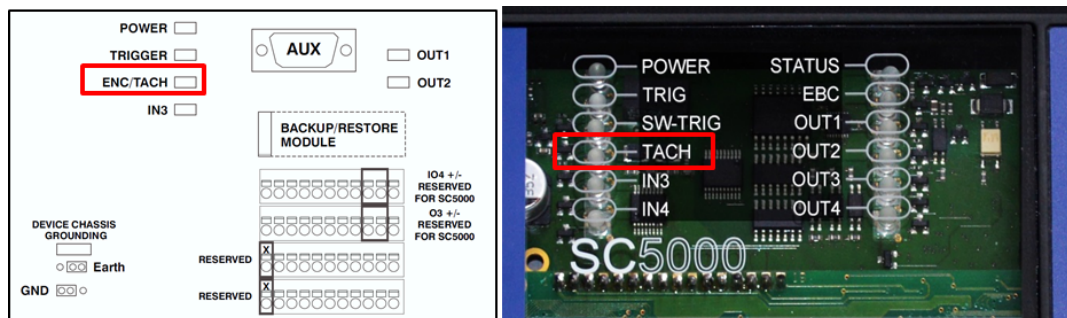

If these indicators do not register feedback when the tachometer wheel is rotated, check the cabling between the tachometer and the CBX510 for damage.





## Chapter 7 Troubleshooting

### WARNING



Due to the complex and application-specific nature of these installations, operational deficiencies of the barcode scanner must be diagnosed and serviced by a trained and authorized Datalogic technician.

There are no user serviceable components or field replaceable units (FRUs) inside the barcode scanner.

For further information on training, contact us through the Datalogic website at [www.datalogic.com](http://www.datalogic.com).

### NOTE



When contacting Datalogic for help with a scanner, please be ready to share the unit serial number with the Datalogic technician. The unit's serial number tag is located on the device, where shown below. Help desk contact information is available at [www.datalogic.com](http://www.datalogic.com).



## LED Diagnostic Indication

The STATUS and READY LEDs blink simultaneously to signal the presence of a failure. Diagnostic message transmission on interfaces can be enabled to provide details about specific failure conditions.

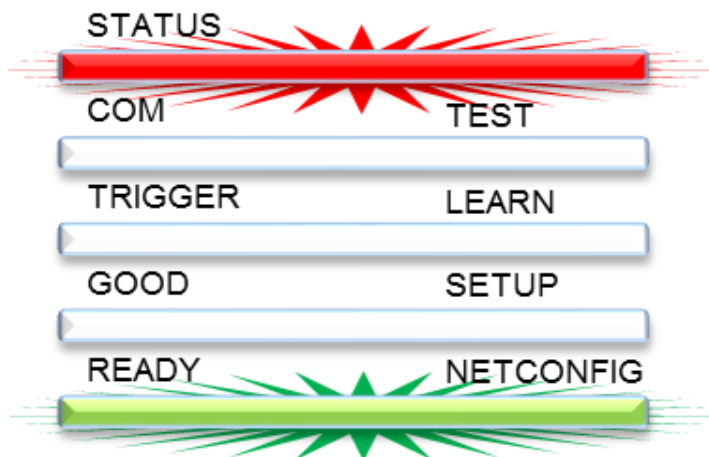

At the same time one or more LEDs light up according to the following scheme:

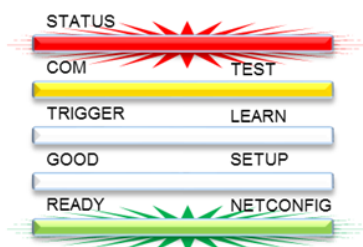

STATUS/READY + COM = Laser Failure

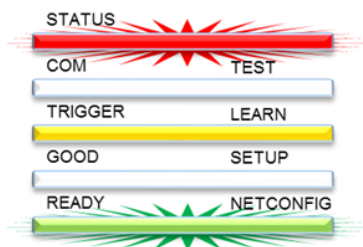

STATUS/READY + TRIGGER = Motor Failure

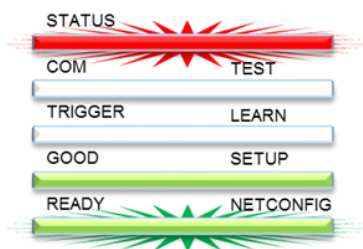

STATUS/READY + GOOD = Other Alarm or Failure

In a **Master-Slave** configuration, all Slave scanner alarms and failures can also be indicated on the Master by turning on the Master's **GOOD** LED. This feature can be enabled by checking the **HMI Settings | LED Settings | Indicate Errors on Master** parameter.



## Error Codes and Resolutions

Error Code	Description	Severity	Explanation	Symptom	Troubleshooting	Action required
1	Node not responding	Error	In a Master/ Slave configuration, the Master monitors the status of the Slaves in its network. If a slave unit fails to be identified, the Master will post this message.	<ul style="list-style-type: none"> <li>- The scanning tunnel's no-read rate increases.</li> <li>- More than one slave unit may be shown as not responding.</li> </ul>	<ul style="list-style-type: none"> <li>- In a tunnel configuration, the cabling that connects the system into to a network must be intact or a scanner will be reported as not responding.</li> <li>- Make sure all the slave units are powered on.</li> </ul>	<ul style="list-style-type: none"> <li>- Make sure cables are connected.</li> <li>- Check scanners power source.</li> <li>- Replace scanner.</li> </ul>
80	Node Reset	Error	In a Master/ Slave configuration, the Master monitors the status of the Slaves in its network. If a Slave resets, it sends a reset message to the Master. The Master then posts this error condition on the diagnostic screen.	<ul style="list-style-type: none"> <li>- The scanning tunnel's no-read rate may increase during the Slave scanner's reconnection.</li> </ul>	<ul style="list-style-type: none"> <li>- This condition is related to a slave scanner. Make sure the power source of the slave is not faulty.</li> </ul>	<ul style="list-style-type: none"> <li>- If condition persists, replace the scanner.</li> </ul>
81	Motor Failure	Error	The scanner's mirror wheel motor has failed.	<ul style="list-style-type: none"> <li>- The scanner will be powered up but will not emit laser light from its exit window.</li> <li>- The scanners motor will not be spinning.</li> </ul>	<ul style="list-style-type: none"> <li>- Hold your hand in front of the scanner to determine if the laser is on.</li> </ul>	<p>This is an internal failure and is not field serviceable</p> <ul style="list-style-type: none"> <li>- Replace scanner.</li> </ul>

Error Code	Description	Severity	Explanation	Symptom	Troubleshooting	Action required
83	Laser Failure	Error	Scanner has a laser failure.	<ul style="list-style-type: none"> <li>- There is no laser light emitted from the scanner</li> <li>- The mirror wheel motor may still be spinning, however, the motor speed may be out of range at which time the scanner will turn off the laser light.</li> </ul>	<ul style="list-style-type: none"> <li>- Hold your hand in front of the scanner to determine if the laser is on.</li> </ul>	<p>This is an internal failure and is not field serviceable.</p> <ul style="list-style-type: none"> <li>- Replace scanner.</li> </ul>
130	Encoder Timeout	Warning	<p>No encoder (tachometer) is detected in specified time. The Encoder signal provides the scanner with belt speed and other tracking information.</p> <p>This error will only occur when the scanner is in the PackTrack mode.</p>	<ul style="list-style-type: none"> <li>- The scanner may experience an increase in no-reads.</li> <li>- The scanner may start missing the transmit point.</li> </ul>	<ul style="list-style-type: none"> <li>- Confirm that the belt is running.</li> <li>- Make sure the encoder (tachometer) wheel is making a firm contact with the conveyor.</li> <li>- Check the <b>Global Settings   Diagnostics   Encoder Timeout</b> setting to confirm that it is not set too low (See 'Diagnostics' on page 159).</li> </ul>	<ul style="list-style-type: none"> <li>- Adjust the encoder (tachometer) mounting.</li> <li>- Adjust the <b>Encoder Timeout</b> setting (See 'Diagnostics' on page 159).</li> </ul>
131	Input 1 Failure	Error	The Primary PS (photoelectric sensor) Input is stuck in the active state (PackTrack Mode).	<ul style="list-style-type: none"> <li>- The scanner will not go into trigger.</li> <li>- No data will be transmitted to the Host.</li> </ul>	<ul style="list-style-type: none"> <li>- Check the alignment of the photoelectric sensor.</li> <li>- Check the functionality of the photoelectric sensor.</li> </ul>	<ul style="list-style-type: none"> <li>- Realign the photoelectric sensor.</li> <li>- Replace the photoelectric sensor.</li> </ul>

Error Code	Description	Severity	Explanation	Symptom	Troubleshooting	Action required
132	No Phase Error	Error	No Phase "time-out" is exceeded (On-Line and PackTrack Mode).  - Trigger must be identified within a specified time.			
133	Input 2 Failure	Error	Secondary PS (photoelectric sensor) Input Failure Stuck Active (PackTrack Mode).	- The scanner will not go into trigger.  - No data will be transmitted to the Host.	- Check the alignment of the photoelectric sensor.  - Check the functionality of the photoelectric sensor.	- Realign the photoelectric sensor.  - Replace the photoelectric sensor.
135	Encoder Failure	Error	Phase input (trigger source) is activated while encoder (tachometer) is stopped (PackTrack Mode).	- No data will be transmitted to the host.  - Scanner(s) will not read any barcodes.  - System receives trigger cycle when no encoder signal is present.	- Check <b>Diagnos</b> <b>tics   Monitor</b> to see if the scanner is reporting a conveyor speed (See section 'Diagnos <b>tics   Monitor</b> ' on page 177 ).  - Make sure the encoder (tachometer) wheel is making a firm contact with the conveyor.	- Adjust, realign, or replace the encoder (tachometer).
157	SD Card Failure	Error	SC5000 - SD card cannot be accessed. The SD card contains the backup files. It also contains a copy of the scanners application software.  This failure is only in the SC5000.	- Unit will not backup or restore the parameters.	Try to save the parameters from the <b>SC5000</b> to the SD card (see SC5000 System Controller Reference Manual).	- Confirm that the SD card is seated properly in the SC5000.  - Replace SD card (see SC5000 System Controller Reference Manual).

Error Code	Description	Severity	Explanation	Symptom	Troubleshooting	Action required
169	Main Serial Port Error	Error	Protocol Index message not received on Main Serial Port.			
176	Aux Serial Port Error	Error	Protocol Index message not received on Aux Serial Port.			
178	Ethernet Socket 1 Error	Error	Protocol Index message not received on User Socket 1.			
179	Ethernet Socket 2 Error	Error	Protocol Index message not received on User Socket 2.			
180	Ethernet Socket 3 Error	Error	Protocol Index message not received on User Socket 3.			
181	Ethernet Socket 4 Error	Error	Protocol Index message not received on User Socket 4.			
182	Ethernet Socket 5 Error	Error	Protocol Index message not received on User Socket 5.			
183	Ethernet Socket 6 Error	Error	Protocol Index message not received on User Socket 6.			
191	Fieldbus Mismatch	Error	Fieldbus module type does not match specified model.  - Module selection incorrect compared to the actual module installed.			

Error Code	Description	Severity	Explanation	Symptom	Troubleshooting	Action required
193	Fieldbus Config Error	Error	Error configuring fieldbus module.	- Unable to communicate to the module.	- Confirm that the unit is not communicating to the host. - Confirm that the fieldbus parameters are configured properly (see section 'Digital I/O' on page 156).	- Replace fieldbus module.
195	Fieldbus DHCP Error	Error	Profinet module had a DHCP error.	- Unable to acquire an IP address.	- Confirm that the unit is not communicating to the host. - Confirm that the fieldbus parameters are configured properly (see section 'Digital I/O' on page 156).	- Replace fieldbus module.
205	APD Temperature Error	Error	APD Temperature sensor is not working. A fluctuation in the scanner's temperature can have an adverse effect on several internal functions of the scanner. The scanner monitors the temperature, and if it is erratic, this error is posted.	- The scanner may experience an increase in no-reads. - The scanner may start missing the transmit point.	1. Cycle power on the scanner; 2. Wait until the unit has time to cool down. 3. Restart the scanner and monitor it to determine whether the error reoccurs.	This is an internal failure and is not field serviceable. - Replace scanner.
207	In Beam Sensor Error	Error	The scanner has an in-the-beam sensor, which provides timing for the decoding of barcodes. The scanner monitors this signal, and posts this error if the signal is sporadic or missing.	- The scanner stops reading barcodes.	- Put the scanner in the test mode to test its ability to read the barcode (see 'Diagnostics   Read Test' on page 179).	This is an internal failure and is not field serviceable. - Replace scanner.

Error Code	Description	Severity	Explanation	Symptom	Troubleshooting	Action required
211	PTP Error	Error	Cannot synchronize the internal clock using the PTP (precision time protocol) protocol. This clock sync pulse is generated by the controller unit. It is used to sync the read data of all the scanners in the network with the master unit.	LEDs flashing.	<ul style="list-style-type: none"> <li>- Confirm that all the scanners are connected in the chain.</li> <li>- Use the scanner test mode to confirm that the scanner can statically read a barcode (see 'Diagnostics   Read Test' on page 179).</li> <li>- Position a barcode on a box so it faces the questionable scanner, and dynamically test the scanner.</li> </ul>	- Replace faulty scanner.
219	Fieldbus Comm Error	Error	Cannot communicate with the fieldbus module.	- The host loses communication with the scanner.	<ul style="list-style-type: none"> <li>- Confirm that the unit is not communicating with the Host.</li> <li>- Confirm that the fieldbus parameters are configured properly (see section 'Digital I/O' on page 156).</li> </ul>	- Replace fieldbus module.

Error Code	Description	Severity	Explanation	Symptom	Troubleshooting	Action required
220	Network Ring Open	Error	When the SC5000 is used, the scanner internal network is connected in a chain configuration. If the SC5000 detects that network chain is not complete, it will post this error.	<ul style="list-style-type: none"> <li>- The system experiences a higher no-read rate.</li> <li>- One or more scanners may not appear on the System Info page (see 'System Information' on page 49).</li> </ul>	<ul style="list-style-type: none"> <li>- Confirm that all the scanners are connected in the chain.</li> <li>- Use the scanner test mode to confirm that the scanner can statically reading a barcode (see 'Diagnostics   Read Test' on page 179).</li> <li>- Position a barcode on a box so it faces the questionable scanner, and dynamically test the scanner.</li> </ul>	<ul style="list-style-type: none"> <li>- Replace faulty scanner.</li> </ul>



# Chapter 8

## Technical Features

This chapter provides detailed specifications for the DS8110 Barcode Scanning Systems. It provides specific information on:

- Electrical Features
- Optical Features
- Reading Features
- Physical Features
- Environmental Features
- X-PRESS Interface
- Software Features

### Technical Specifications

<b>ELECTRICAL FEATURES</b>	
<b>Power</b>	
Supply Voltage	20-30VDC
Consumption	0.72 to 0.5 A Max. (1.3 A max peak at motor start-up) 20 W typical
Distributable Current (through I/O connector)	0.6 A Max.
<b>Communication Interfaces</b>	
Main RS232	1200 to 115200 bit/s
Main RS422 full-duplex	1200 to 115200 bit/s
Auxiliary RS232	1200 to 115200 bit/s
Ethernet (x2) TCP/IP	100 Mbit/s
EBC Internal Network	100 Mbit/s
<b>Fieldbus</b>	Embedded: EtherNet/IP Supported through CBX510 connection box or SC5000 models: PROF- INET-IO, PROFIBUS-DP
<b>Inputs</b>	3 opto-coupled and polarity insensitive NPN/PNP digital inputs (5-30 Vdc)
<b>Outputs</b>	2 opto-coupled software programmable NPN digital outputs



**OPTICAL FEATURES**

Wavelength	630 to 680 nm
Safety Class	Class 2 - EN60825-1; Class II – CDRH
Light Source	Visible laser diode
Laser Control	Security system to turn laser off in case of motor slow down
Optic Architecture / Technology	ASTRA™
Focusing System	Fixed focus position

**READING FEATURES**

Scan Rate	Typ.:1000 scans/s/ Max.
Maximum Resolution	Min:0.25mm (10mils)/Max: 1.0mm (40mils)
Max. Reading Distance	See section Reading Diagrams
Max. Reading Width	See section Reading Diagrams
Max. Depth of Field	See section Reading Diagrams
Scan Pattern Type	Linear

**PHYSICAL FEATURES**

Dimensions	216 x 96 x 127 mm [8.5 x 3.8 x 5.0 in]
Weight	2.0 kg (4.4 lb)
Enclosure	Aluminum Alloy
Connections	I/O, POWER, ETH1, ETH2; Other connections through CBX510

**ENVIRONMENTAL FEATURES**

Temperature	Operating: 0 to 50 °C (32 to 122 °F) Storage: -20 to 70 °C (-4 to 158 °F)
Relative Humidity	10-90% non-condensing
Ambient light immunity	>30,000 LUX
Vibration Resistance ①	SINE vibration as per EN60068-2-6 2-10Hz : 14mm / 13-55Hz : 1.5mm / 70-500Hz : 2g 2h per axis / 3 axes
Shock Resistance	As per EN60068-2-27, 30g / 11ms / 3 times up and 3 times down on each axis / 3 axes
Protection Class	IP65

**X-PRESS INTERFACE**

LED Indicators	Ready, Good, Trigger, Com, Status
Keypad	HMI Keypad for alternative configuration and test mode and Restore Factory Default

---

**SOFTWARE FEATURES**

---

Readable Code Symbologies

---

? Code 128	? GS1-128	? EAN-8/13 - UPC-A/E (including Addon 2 and Addon 5)
? Interleaved 2 of 5	? Codabar	
? Code 39 (Standard)	? Code 93	

---

Operating Mode	On Line, Continuous, PackTrack™, Test
----------------	---------------------------------------

---

Configuration Methods	e-Genius multilanguage, browser-based, on board HTML web server interface X-PRESS™ HMI key functions
-----------------------	---

---

Multilabel Reading	Up to 10 different symbologies during the same reading phase
--------------------	--

---

Headers and Terminators	Up to 128-byte headers and 128-byte terminators
-------------------------	---

---

Code Reconstruction Technology	ACR™
--------------------------------	------

---

Parameter Storage	Non-volatile internal FLASH
-------------------	-----------------------------

---

**OTHER**

---

Service Options	Installation services and on-site training
-----------------	--

---

Warranty	2-year limited, parts and labor
----------	---------------------------------

---



# Index

## A

Accessories 6  
ACR™ 232  
Applications 3

## B

Barcode Configuration 75  
Logical Combination 87  
Single Label 79  
Standard Multi Label 83  
Barcode Settings 68  
Barcode Settings Table 68  
Barcode\_Configuration 75  
Block Diagram  
Typical Connections 23

## C

CBX Connection Box  
Encoder Wiring 33  
Tachometer Wiring 33  
CBX510 11  
Digital Outputs 38  
Installation with 192  
Photoelectric Sensor Connection 31  
Relay Configuration 38  
CBX510 Connections 28  
CE COMPLIANCE xi  
Code Collection 97  
CODE COLLECTION GLOBAL NO READ 78  
Connecting 22  
Connecting a Laptop 27  
Connecting a PC 27  
Connection  
Typical 23  
Connector Panel  
DS8110 26

## D

Device Settings 168  
Device Info 169  
Mounting 171  
Options 173  
Diagnostics 159  
Monitor 177  
Read Test 179  
Status Viewer 180  
Diagnostics Messages 153

---

Digital\_I\_O 156  
DS8110 Description 1

## E

e-Genius 54, 179, 180, 184, 186, 187, 189, 190  
Barcode Settings  
Advanced Decode 76  
e-Genius Basics 47  
e-Genius Online Help 48  
e-Genius, Starting 43  
e-Genius, starting 43  
Electrical  
high-voltage precautions 27  
installation sequence recommended 225  
Electrical Installation  
Guidlines 25  
ELECTRICAL SAFETY ix  
Encoder 9  
Wiring 33  
Energy Saving 163  
Ethernet 108, 158, 162, 166, 167, 168, 169, 171, 173  
Line Settings 109, 111  
User Sockets 111  
WebSentinel 119, 126, 127, 139  
Ethernet\_IP 115  
External Function Buttons 5

## F

FCC Compliance xii  
Fieldbus 121

## G

Grounding 42  
H  
Help 48  
HMI 5, 167  
HMI Settings 167  
Human Machine Interface 5, 167

## I

Installation  
CBX510 192  
Checking 42  
Grounding 42  
Preparing for 21  
Preparing for Mechanical 13  
sequence recommended 225  
What you need to know 15  
Installation Sequence 14  
Interfaces  
Main 29  
Main RS232 29  
Main RS485 Full Duplex 30

## L

Laptop

Connecting 27  
LASER SAFETY ix  
LED Diagnostic Indication 252  
LED Indicators 202  
Line Settings 109  
LOCAL NO READ 76  
Logical Combination 87  
Logical Combination Rule 87  
LOGICAL COMINATION LOCAL NO READ 78

## M

Maintenance Tasks 247  
Menu Tree 47  
Message Builder 139  
Message Format 127  
Messaging 126, 158, 162, 166, 167, 168, 169, 171, 173  
Pass Thru 151  
Model Description 5  
Modify Settings 52  
Monitor 177  
Mounting Specifications ERGEFORMAT 207

## O

Online Help, e-Genius 48  
Operating Mode 54

## P

PackTrack  
Verifying Calibration 223  
PackTrack Calibration Wizard 172  
Packtrack Calibration Wizard ERGEFORMAT 207  
PackTrack Wizard 208  
PackTrack Wizard ERGEFORMAT 207  
Pass Thru 151  
Pass-Thru 151  
Patents vii  
Connecting 27  
Performance 233  
Photoelectric Sensor  
Wiring 31  
Pinout  
Power Connector 27  
Power Connector Pin-Out Table 27  
Power Supply xi  
Prerequisites, user interface 43  
Protective Earth 42  
Protocol Index 147

## R

Read Charts 235  
Read Test 179  
Reading Diagrams 235  
Replacing a DS8110 225  
Reset Buttons 48

---

## **S**

SC5000 12  
Serial Ports 102  
Aux Port 106  
Main Port 103  
SINGLE LABEL GLOBAL NO READ 77  
Standard Multi Label 83  
STANDARD MULTI LABEL GLOBAL NO READ 78  
STANDARD MULTI LABEL LOCAL NO READ 77  
Standard Regulations ix  
Starting e-Genius 43  
Statistics 145  
Status Viewer 180  
System Info 49

## **T**

Tachometer 9  
Wiring 33  
Text Entry 47  
Text Entry Tool 47  
Typical Layouts 228

## **U**

UL Listing xi  
Unpacking 14  
Update Firmware 187

User Sockets 111

## **V**

Versions 5

## **W**

Warning Labels x  
WebSentinel 119  
Wiring  
Encoder 33  
Photoelectric Sensor 31  
Tachometer 33

## **X**

X-Press 5





© 2015-2018 Datalogic S.p.A. and /or its affiliates ▪ All rights reserved. ▪ Without limiting the rights under copyright, no part of this documentation may be reproduced, stored in or introduced into a retrieval system, or transmitted in any form or by any means, or for any purpose, without the express written permission of Datalogic S.p.A. and/or its affiliates ▪ Datalogic and the Datalogic logo are registered trademarks of Datalogic S.p.A. in many countries, including the U.S. and the E.U.



[www.datalogic.com](http://www.datalogic.com)

**Datalogic S.r.l.**

Via S. Vitalino, 13 | 40012 Calderara di Reno | Bologna - Italy  
Tel. +39 051 3147011 | Fax +39 051 3147205



821005940

(Rev. A)

April 2019

