

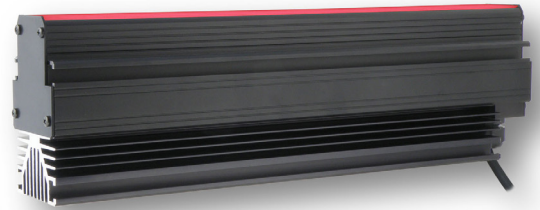

Expandable

### Product Highlights

- 510,000 lux - perfect for line-scanning applications
- Available 6" (152.4mm) increments from 6" (152.4mm) to 96" (2438.4mm) with the exception of a 3" (76.2mm) model
- Intensity control of entire light via 0 - 10v input



### General Specifications

	Color	24v Current	All Other Controls
Electrical Specifications	850, RGB	0.64 A per 6 inches	0.64 A Max per 6 inches
	625	0.64 A per 6 inches	0.64 A Max per 6 inches
	455, 530, WHI	0.75 A per 6 inches	0.75 A Max per 6 inches
Normal Operating Temperature	0 - 60°C		
Weight (g)	Per 12" 1211.1g (42.72oz)		
Standard Cable Information	Up to 2 meters (80") long - 105°C rated PVC jacket, foil shield with drain.		
Photobiological Risk Factor IEC 62471	<b>Exempt Applicable Wavelengths:</b> 850 <b>Group 1 (Low-Risk) Applicable Wavelengths:</b> 455, 530, 625, RGB, WHI		
Compliance			
IP Rating	Unsealed - IP50		
Lumen Maintenance	L70 = 50,000 hours		

# BL138 Expandable Series

## Mechanical Specifications

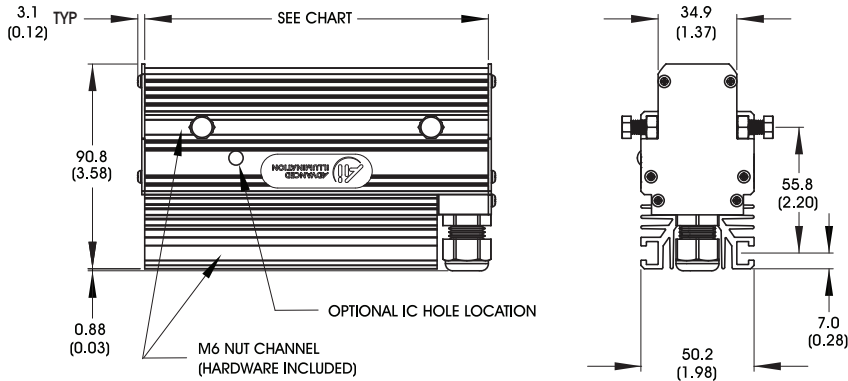

Part #	Length in mm (inches)
BL13803	76 (3)
BL13806	152 (6)
BL13812	305 (12)
BL13818	457 (18)
BL13824	610 (24)
BL13830	762 (30)
BL13836	914 (36)
6" Increments up to a max of 96"	

DIMENSIONS ARE IN MILLIMETERS (INCHES)

## Part Number Key

Model	Lighted Length	—	Spectral Wavelength	Connector/Control
<b>BL138</b>	<b>XX</b>	<b>—</b>	<b>XXX</b>	<b>XX</b>
BL138	03" model available as well as 6" increments up to 96"		(blue) 455 (green) 530 (red) 625 (infra-red) 850 (all colors) RGB <sup>1</sup> (white) WHI	C1 C5 IC <sup>2</sup> 24v
<b>Ex: BL13806-455C1</b> <b>BL13824-625IC</b>			<sup>1</sup> Not available in IC <sup>2</sup> IC option (see page 4 for details) not available with 3" model	

**Stock Product:** ships within 3 days  
None

**Build to Order:** shipped within two weeks

## Connector | Control Options

C1 Connector	IC	24
For use with: DCS Series Controllers	Please see page 4 for IC information	Flying/tinned leads Powered with: 24V power supply

# BL138 Expandable Series

## Optical Performance

### Intensity Distribution

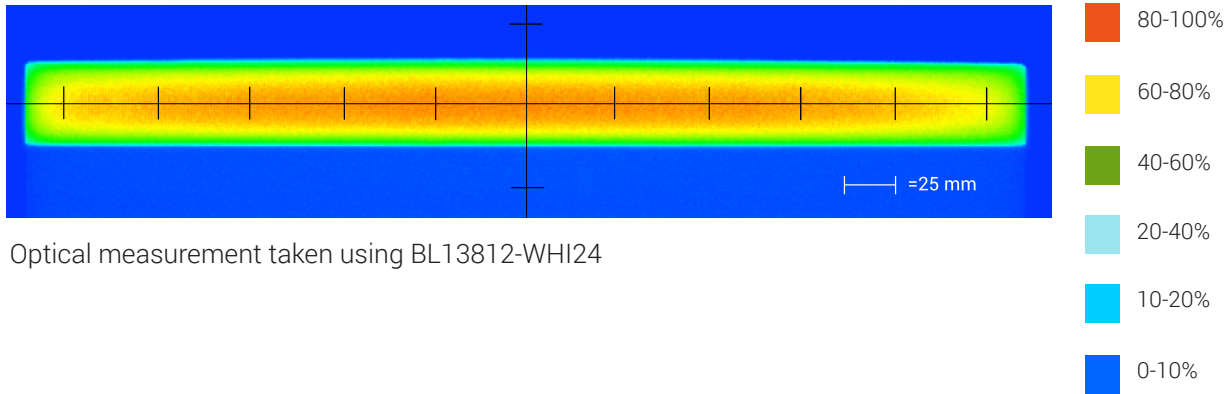

### Area of Illuminance & Intensity

Working Area (FWHM)  
@ Working Distance

297.2 X 17.8 (mm)  
@Surface



Light Output

Irradiance (W/M<sup>2</sup>): Min 1173; Typ 1380  
Illuminance (kLux): Min 433.5; Typ 510

## Operation and Wiring

### 24 Volt

Function	Wire Color
+24v DC	Brown
0-10v DC Analog Control	White
GND	Blue
N/A	Black

The entire light's intensity can be controlled via external 0-10 V analog controller using the white wire

### 0-10V ANALOG CONTROL LINEAR OUTPUT ADJUST

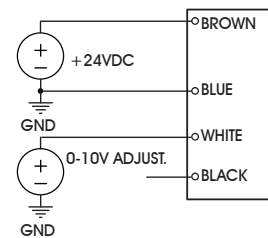

# BL138 Expandable Series

## IC Control



The IC option allows for control of intensity on each 6" (152mm) section of BL138, BL168, LL137 and LL167 **only**. Fig. 1 shows 5 segments of 6" (152mm) BL138 with IC adjustment holes.

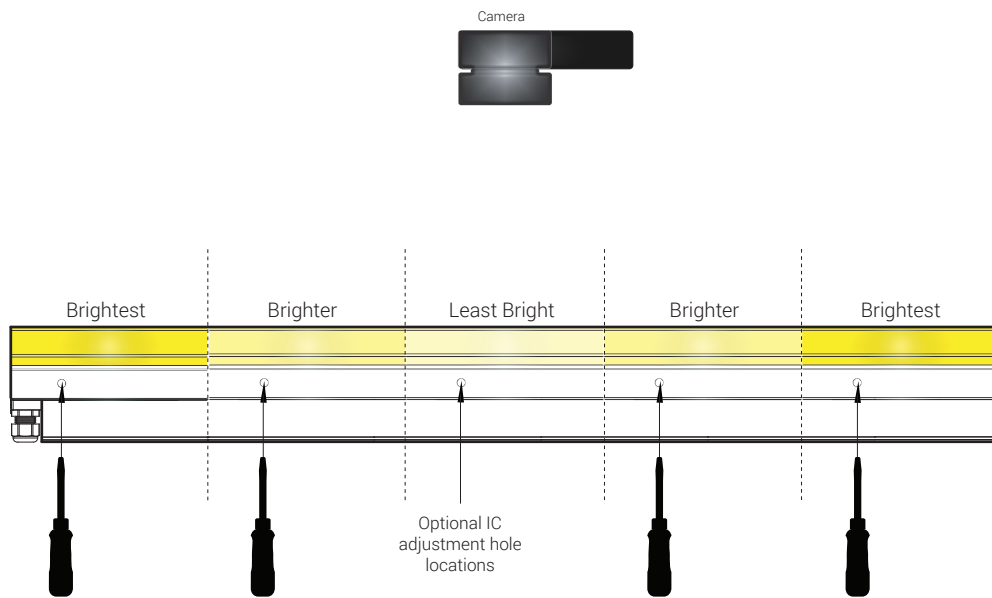

(fig. 1)

Controlling each 6" (152mm) section independently and making the center of the line less bright and the outside of the immediate camera viewing radius brighter ultimately results in better imaging.

Better imaging occurs because the camera can see very well in it's area of focus, but outside that area the camera doesn't focus as well without brighter illumination.

Ai recommends using IC adjustment holes for aforementioned lights over 24" (610mm) long.

# BL138 Expandable Series

## Warranty Information

Every Advanced illumination, Inc. (Ai) product is thoroughly inspected and tested before leaving the factory. Products are warranted to be free of defects in workmanship and materials for a period of two years from the original date of purchase. Should a defect develop during this period, please contact Ai Customer Service or your Ai distributor for a Return Merchandise Authorization (RMA), and return the complete product, freight prepaid, to Ai. If a defect is found, Ai will - at our discretion - repair or replace the product without charge. Ai claims no liability for any implied warranties, including "merchantability" and "fitness for a specific purpose."

## Electromagnetic Compatibility

This product was tested and complies with the regulatory requirements and limits for electromagnetic compatibility (EMC) as stated in the product specifications. These requirements and limits are designed to provide reasonable protection against harmful interference only when the product is operated in its intended industrial electromagnetic environment. To minimize the potential for electromagnetic interference or unacceptable performance degradation, install and use this product in strict accordance with the instructions in the product documentation.

## Customer Service

For information on existing orders, or to make an order adjustment, contact us Monday through Friday 8:00 am to 5:00 pm, EST or send an email to [orders@advill.com](mailto:orders@advill.com).

## Company Information

### **Advanced Illumination**

440 State Garage Road, Rochester VT. 05767

Phone: 802.767.3830

Fax: 802.767.3831

Email: [info@advancedillumination.com](mailto:info@advancedillumination.com)

Web: [advancedillumination.com](http://advancedillumination.com)

© 2015 Advanced Illumination Inc. All rights reserved