



DLR-TL001

UHF-Semi-Passive Logger Tag



Quick Reference Guide

Datalogic S.r.l.

Via S. Vitalino, 13
40012 Calderara di Reno
Italy
Tel. +39 051 3147011
Fax +39 051 3147205

©2016-2017 Datalogic S.p.A. and/or its affiliates

An Unpublished Work - All rights reserved. No part of the contents of this documentation or the procedures described therein may be reproduced or transmitted in any form or by any means without prior written permission of Datalogic S.p.A. and/or its affiliates. Owners of Datalogic products are hereby granted a non-exclusive, revocable license to reproduce and transmit this documentation for the purchaser's own internal business purposes. Purchaser shall not remove or alter any proprietary notices, including copyright notices, contained in this documentation and shall ensure that all notices appear on any reproductions of the documentation. Should future revisions of this manual be published, you can acquire printed versions by contacting your Datalogic representative.

Electronic versions may either be downloadable from the Datalogic website (www.datalogic.com) or provided on appropriate media. If you visit our website and would like to make comments or suggestions about this or other Datalogic publications, please let us know via the "Contact Datalogic" page.

Disclaimer

Datalogic has taken reasonable measures to provide information in this manual that is complete and accurate, however, Datalogic reserves the right to change any specification at any time without prior notice.

Datalogic and the Datalogic logo are registered trademarks of Datalogic S.p.A. in many countries, including the U.S.A. and the E.U..

DLR-TL001 is a trademark of Datalogic S.p.A. and/or its affiliates. All other trademarks and brands are property of their respective owners.

See the Regulatory Addendum included with your product for additional regulatory, safety and legal information.



Table of Contents

END USER SOFTWARE LICENSE AGREEMENT (EULA)	iii
Software Product Policy	vi
General Information	2
Ordering Code	3
DLR-TL001 Functional Description	4
Main Features	4
Operating States	4
Manual Interface Behaviour	5
Histogram Functionality Description	7
Mean Kinetic Temperature Calculation	7
Remaining Shelf Life Calculation	8
Battery Measurement and Behaviour	8
DLR-TL001 Memory Description	9
Address Space	9
EPC	9
TID.....	9
RESERVED	10
USER MEMORY	11
User Memory map	11
Two Main Register Descriptions	12
DLR-TL001 Specifications	14
Technical Specifications	14
Air Link Protocol Characteristic (Physical Layer)	16
DLR-TL001 Temperature Measurement Traceability	18
Datalogic Limited Factory Warranty	19
Services and Support	22

NOTES

DATALOGIC IP TECH S.R.L.

END USER SOFTWARE LICENSE AGREEMENT (EULA)

FOR THE DLR-TL001

Notice to End User: There are two types of software covered by this END USER LICENSE AGREEMENT ("EULA"): (1) The Datalogic Product you have acquired contains embedded software ("Embedded Software") which is integral to the Product's operation; and (2) Optional Application Software provided to you on an optional basis ("Application Software"). Embedded Software and Application Software are collectively referred to as "Software" and are subject to the terms and conditions contained in this EULA. Software is provided only for use with, and for authorized end users of, the Datalogic DLR-TL001 ("Product").

This EULA (End User Software License Agreement) ("EULA" or "Agreement") is a legally binding agreement governing the licensing of the Software and Documentation by Datalogic IP Tech S.r.l. and its subsidiaries and affiliates ("Datalogic") to the entity or person who has purchased or otherwise acquired a Datalogic Product ("End User"). For purposes of this Agreement, any software that is not Embedded Software or Application Software is software associated with a separate end-user license agreement is licensed to you under the terms of that license agreement. Datalogic and End User hereby agree as follows:

1. Definitions

- 1.1 "Affiliate" means a business entity currently existing or later acquired that is controlled by, or is under common control with Datalogic S.p.A.
- 1.2 "Documentation" means materials such as user's guides, program reference guides, quick reference guides, manuals, or similar materials associated with or related to the Datalogic Product, whether in printed, "online", or other form.
- 1.3 "Proprietary Information" means: (a) source code, object code, software, documentation, and any related internal design, system design, data base design, algorithms, technology, technical data or information, implementation techniques, and trade secrets related to the Software, (b) any other trade secrets marked appropriately or identified as proprietary or confidential, and (c) any information that End User, under the circumstances, should recognize as confidential. Proprietary Information does not include any information that the receiving party can establish was (1) in the public domain, (2) already in the receiving party's possession or rightfully known prior to receipt, (3) rightfully learned from a third party not in violation of any other's proprietary rights, or (4) independently developed without access to Proprietary Information.
- 1.4 "Datalogic Product" means the Datalogic DLR-TL001 series reader product, including all embedded Software in and all Documentation related to such product, which has been purchased or otherwise acquired by End User, whether obtained directly or indirectly from Datalogic
- 1.5 "Software" means any software or computer programs of Datalogic or its third party licensors in machine readable form which is embedded in the Datalogic Product, whether obtained directly or indirectly from Datalogic, including any replacement, update, upgrade, enhancement or modification.

2. Scope Of License Granted

- 2.1 Datalogic grants to End User a personal non-exclusive, non-transferable, perpetual license to use the Software, solely on the Datalogic Product in which it is embedded ("designated Datalogic Product"), in machine-readable form only, solely for End User's internal business purposes. This Agreement does not convey ownership of the Software to End User. Title to the Software shall be and remain with Datalogic or the third party from whom Datalogic has obtained a licensed right. As used in this Agreement, the term "purchase" or its equivalents when applied to the Software shall mean "acquire under license." End User is not entitled to receipt or use of the source code to any Software.
- 2.2 End User shall not copy, modify, decompile, disassemble, reverse engineer, or otherwise reproduce or remanufacture the Software, whether modified or unmodified, nor sell, assign, sublicense, distribute, lend, rent, give, or otherwise transfer the Software to any other person or organization, for purposes other than as expressly provided in this Agreement, without Datalogic's prior written consent.

3. Transfers, Support

- 3.1 Any copying, installing, reproduction, remanufacture, reverse engineering, electronic transfer, or other use of the Software on other than the designated Datalogic Product will be a material breach of this Agreement. However, Datalogic may elect not to terminate this Agreement or the granted licenses, but instead may elect to notify End User that End User is deemed to have ordered and accepted a license for each breaching use. End User shall pay Datalogic the applicable list price for such licenses as of the date of such breach.
- 3.2 End User shall not sell, assign, sublicense, distribute, lend, rent, give, or otherwise transfer the Datalogic Product to any third party unless such third party agrees with Datalogic in writing to be bound by the terms and conditions of this Agreement. Any such transfer of the Datalogic Product absent such agreement shall be null and void.
- 3.3 End User may obtain support for Software from Datalogic at Datalogic's standard support fees and under Datalogic's standard support terms and conditions in effect at the time the support is requested.

4. Intellectual Property

End User acknowledges that the Software comprises valuable trade secrets of Datalogic or Datalogic's third party licensors and that the Software is protected by United States copyright law and trade secret law, and by all applicable international intellectual property laws and treaty provisions. The license set forth in this Agreement does not transfer to End User any ownership of Datalogic's or its third party licensors' copyrights, patents, trademarks, service marks, trade secrets, or other intellectual property rights and End User shall have no right to commence any legal actions to obtain such rights. End User shall not remove, modify, or take any other action that would obscure any copyright, trademark, patent marking, or other intellectual property notices contained in or on the Datalogic Product.

5. Proprietary Information

- 5.1 End User acknowledges that Proprietary Information is the confidential, proprietary, and trade secret property of Datalogic and Datalogic's third party licensors and End User acquires no right or interest in any Proprietary Information.
- 5.2 End User shall not disclose, provide, or otherwise make available the Proprietary Information of Datalogic or its third party licensors to any person other than End User's authorized employees or agents who are under confidentiality agreement, and End User shall not use the Proprietary Information other than in conjunction with use of the Datalogic Product exclusively for End User's internal business purposes. End User shall take steps to protect the Proprietary Information no less securely than if it were End User's own intellectual property.
- 5.3 The provisions of this Proprietary Information Section shall survive and continue for five (5) years after the termination of this Agreement.

6. Limited Warranty

- 6.1 Datalogic warrants that, under normal use and operation, the Datalogic Product will conform substantially to the applicable Documentation for the period specified in the Documentation. During this period, for all reproducible nonconformities for which Datalogic has been given written notice, Datalogic will use commercially reasonable efforts to remedy nonconformities verified by Datalogic. End User agrees to supply Datalogic with all reasonably requested information and assistance necessary to help Datalogic in remedying such nonconformities. For all defects reported to Datalogic within the warranty period, Datalogic's liability is limited to providing End User with one copy of corrections or responding to End User's problem reports according to Datalogic's standard assistance practices. Datalogic does not warrant that the product will meet End User's requirements or that use of the product will be uninterrupted or error free, or that Datalogic's remedial efforts will correct any nonconformance. This limited warranty does not cover any product that have been subjected to damage or abuse, whether intentionally, accidentally, or by neglect, or to unauthorized repair or unauthorized installation, and shall be void if End User modifies the product, uses the product in any manner other than as established in the Documentation, or if End User breaches any of the provisions of this Agreement.
- 6.2 EXCEPT AAS PROVIDED IN THIS AGREEMENT, THE DATALOGIC PRODUCT IS PROVIDED "AS IS" AND DATALOGIC MAKES NO WARRANTIES OF ANY KIND, EXPRESS OR IMPLIED, WRITTEN OR ORAL, WITH RESPECT TO THE PRODUCT, AND SPECIFICALLY DISCLAIMS THE IMPLIED WARRANTIES OF MERCHANTABILITY AND FITNESS FOR A PARTICULAR PURPOSE.

7. Limitation Of Liability

EXCEPT AS PROVIDED IN THIS AGREEMENT, DATALOGIC SHALL NOT BE LIABLE FOR ANY CLAIMS AGAINST END USER BY ANY OTHER PARTY. IN NO EVENT SHALL DATALOGIC'S LIABILITY FOR DAMAGES, IF ANY, WHETHER BASED UPON CONTRACT, TORT (INCLUDING NEGLIGENCE), PRODUCT LIABILITY, STRICT LIABILITY, WARRANTY, OR ANY OTHER BASIS, EXCEED THE PRICE OR FEE PAID BY END USER FOR THE DATALOGIC PRODUCT. UNDER NO CIRCUMSTANCES SHALL DATALOGIC BE LIABLE TO END USER OR ANY THIRD PARTY FOR LOST PROFITS, LOST DATA, INTERRUPTION OF BUSINESS OR SERVICE, OR FOR ANY OTHER SPECIAL, CONSEQUENTIAL, CONTINGENT, INDIRECT, INCIDENTAL, PUNITIVE, EXEMPLARY, OR OTHER SIMILAR DAMAGES, EVEN IF DATALOGIC HAS BEEN ADVISED OF THE POSSIBILITY OF SUCH DAMAGES.

8. Government Restricted Rights; International Use

- 8.1 Use, duplication, or disclosure of the Software by the U.S. Government is subject to the restrictions for computer software developed at private expense as set forth in the U.S. Federal Acquisition Regulations at FAR 52.227-14(g), or 52.227-19 or in the Rights in Technical Data and Computer Software clause at DFARS 252.227-7013(c)(1)(ii), whichever is applicable.
- 8.2 If End User is using the Datalogic Product outside of the United States, End User must comply with the applicable local laws of the country in which the Datalogic Product is used, with U.S. export control laws, and with the English language version of this Agreement. The provisions of the "United Nations Convention on International Sale of Goods" shall not apply to this Agreement.

9. Termination

- 9.1 Either party may terminate this Agreement or any license granted under this Agreement at any time upon written notice if the other party breaches any provision of this Agreement.

Upon termination of this Agreement, End User immediately shall cease using any nonembedded software and shall return to Datalogic or destroy all non-embedded software covered by this Agreement, and shall furnish Datalogic with a certificate of compliance with this provision signed by an officer or authorized representative of End User. For embedded software, End User agrees to sign a waiver prepared by Datalogic concerning further use of the embedded Software. End User's resumed or continued use of the embedded Software after termination shall constitute End User's agreement to be bound by the terms and conditions of this Agreement for such use.

10. General Provisions

- 10.1 Entire Agreement; Amendment. This document contains the entire agreement between the parties relating to the licensing of the Software and supercedes all prior or contemporaneous agreements, written or oral, between the parties concerning the licensing of the Software. This Agreement may not be changed, amended, or modified except by written document signed by Datalogic.
- 10.2 Notice. All notices required or authorized under this Agreement shall be given in writing, and shall be effective when received, with evidence of receipt. Notices to Datalogic shall be sent to the attention of Datalogic IP Tech S.r.l., Legal & IP Department, Via San Vitalino 13, 40012 Calderara di Reno (Bologna), Italy or such other address as may be specified by Datalogic in writing.
- 10.3 Waiver. A party's failure to enforce any of the terms and conditions of this Agreement shall not prevent the party's later enforcement of such terms and conditions.
- 10.4 Governing Law; Venue: Both parties agree to the application of the laws of the country in which End User obtained the license to govern, interpret, and enforce all of End User's and Datalogic's respective rights, duties, and obligations arising from, or relating in any manner to, the subject matter of this Agreement, without regard to conflict of law principles. The United Nations Convention on Contracts for the International Sale of Goods does not apply.

All rights, duties, and obligations are subject to the courts of the country in which End User obtained the license. For licenses granted by Licensee who operates in the countries specified below, the following terms applies.

For Americas.

This Agreement is governed by the laws of the State of Oregon. This Agreement and the rights of the parties hereunder shall be governed by and construed in accordance with the laws of the State of Oregon U.S.A, without regard to the rules governing conflicts of law. The state or federal courts of the State of Oregon located in either Multnomah or Lane counties shall have

exclusive jurisdiction over all matters regarding this Agreement, except that Datalogic shall have the right, at its absolute discretion, to initiate proceedings in the courts of any other state, country, or territory in which End User resides, or in which any of End User's assets are located. In the event an action is brought to enforce the terms and conditions of this Agreement, the prevailing party shall be entitled to reasonable attorneys' fees, both at trial and on appeal.

For Europe, Middle East and Africa

This Agreement is governed by the laws of Italy. This Agreement and the rights of the parties hereunder shall be governed by and construed in accordance with the laws of Italy, without regard to the rules governing conflicts of law. Italian Court of Bologna shall have exclusive jurisdiction over all matters regarding this Agreement, except that Datalogic shall have the right, at its absolute discretion, to initiate proceedings in the courts of any other state, country, or territory in which End User resides, or in which any of End User's assets are located. In the event an action is brought to enforce the terms and conditions of this Agreement, the prevailing party shall be entitled to reasonable attorneys' fees, both at trial and on appeal.

For Asia- Pacific Countries

This Agreement is governed by the laws of the State of Hong Kong. This Agreement and the rights of the parties hereunder shall be governed by and construed in accordance with the laws of the State of Hong Kong without regard to the rules governing conflicts of law. The Court of Hong Kong shall have exclusive jurisdiction over all matters regarding this Agreement, except that Datalogic shall have the right, at its absolute discretion, to initiate proceedings in the courts of any other state, country, or territory in which End User resides, or in which any of End User's assets are located. In the event an action is brought to enforce the terms and conditions of this Agreement, the prevailing party shall be entitled to reasonable attorneys' fees, both at trial and on appeal.

10.5 Attorneys' Fees. In the event an action is brought to enforce the terms and conditions of this Agreement, the prevailing party shall be entitled to reasonable attorneys' fees, both at trial and on appeal.

- END -

Software Product Policy

Datalogic reserves the right to ship its products with the latest version of software/firmware available. This provides our customers with the very latest in Datalogic software technology.

The only exception to this policy is when the buyer has a signed contract with Datalogic that clearly defines the terms and conditions for making software/firmware changes in products shipped to the buyer.

To arrange for a Software Maintenance and Support Agreement please contact your Datalogic sales person.



DLR-TL001 LOGGER

General Information

Datalogic RFID DLR-TL001 is a low cost, semi-passive UHF Logger TAG that allows to monitor temperature sensitive products during transportation or storage. DLR-TL001 is compliant to the EPC Class1 Gen2/ISO18000-6C standards and it can be used with the Gen2 UHF RFID readers on the market without any additional equipment. Once configured using the RFID interface, the logger can be activated by a simple manual interface that includes a button (see [Figure 1. on page 5](#)). The TAG will start to monitor the life of a temperature sensitive product allowing to identify problems occurred along the whole cold chain in a fast and effective way.

The logger is configurable either in Continuous or Over-Threshold logging modes and it allows to define up to 16 independent histogram bins for its full temperature range. Each histogram permits to have different programmable sampling times. Temperature logging and alarms generation can be enabled or disabled independently for each histogram bin.

The TAG is also able to calculate the Mean Kinetic Temperature and the remaining shelf life time and to generate alarms in case these parameters exceed user defined thresholds.

The tag can generate alarms for the following conditions:

- The counter of a histogram bin exceeds the defined threshold.
- The Mean Kinetic Temperature value exceeds the defined threshold.
- The remaining Shelf life is less than the defined threshold.
- The logging memory is full.
- The elapsed time from the start of the logging exceeds the defined Estimated Time of Arrival (ETA).



For more details on Registers, please refer to the Product Reference Guide (PRG).

NOTE

Ordering Code

CODE	DESCRIPTION
DLR-TL001	Temperature Logger UHF semi-passive TAG

DLR-TL001 Functional Description

Main Features

- EPC C1G2 (ISO18000-6C) Compatible
- Frequency range: 860 MHz - 928 MHz
- Read range: approx. 10m in air @ 2W ERP
- Unique TID plus long EPC code (512 bit)
- Memory capacity: 4k samples (8 Kbyte)
- Multiple programmable sampling interval
- Multiple programmable temperature thresholds
- Multiple programmable alarms
- Temperature Histogram function
- Mean Kinetic Temperature function
- Remaining Shelf Life function
- Easy to use manual interface
- Battery Life: 1 year min
- Temperature range: -10°C to 60°C
- Accuracy: $\pm 0.5^{\circ}\text{C}$
- Dimensions: 107 x 107 x 6.6 mm³
- Enclosure degree of Protection IP67
- Battery charge status monitoring through RF or manual interface

Operating States

DLR-TL001 tag behaves according to the following operating states:

Stand-by. Stand-by is the starting state of the tag. In this state the tag responds to reader interrogations, the log memory is empty and the internal clock has not yet started. This is the lower power consumption state.

Idle. The tag is in Idle state when the internal clock is running, the memory is empty and the tag is waiting for a start logging command. The start command can be issued either by an RFID command or by the button.

Active. The tag enters the Active state after having received the start logging command, in this state the tag wakes up at defined intervals in order to acquire tempera-

ture samples and, eventually, it stores those samples inside the log memory.

Sleep. The tag enters the Sleep state at the end of a logging activity. Differently from the Idle state, in Sleep state the tag's log memory is not empty and it is retained until a reset command is issued.

Manual Interface Behaviour

The DLR-TL001 tag has a simple manual interface that includes a button and a bicolor red/green LED that, depending on the configuration, allows to check the status of the alarms and to start/stop the logging activity. By default, the button can be used only to check the status of the tag but not to start/stop the logging activity. Start/stop function can be activated by setting the Button Enable (BE) bit in the CONTROL register.

Figure 1. Manual Interface

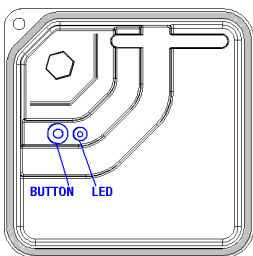

The manual interface behaves as follows:

Pressing the button quickly (less than 2 second) activates the check status function:

- If the battery level is still sufficient for the logging activity and no alarms are active, the green LED will stay lit for 2 seconds.
- If the battery level is still enough for the logging activity but there are active alarms, the red LED will stay lit for 2 seconds. The alarms causing the red LED to light are the following:
 - Memory full (see MEMFULL bit in the STATUS register description; refer to the Product Reference Guide for more details).

- ETA alarm (see ETA_ALARM bit in the STATUS register description: exceeding an estimated time).
 - Bin counters alarm (see BIN_ALMR bit in the STATUS register description: at least one histogram went above its preset THR - threshold).
 - Mean Kinetic alarm (see MKT_ALARM bit in the STATUS register description: temperature over a calculated THR).
 - Shelf life alarm (see SHL_ALARM bit in the STATUS register description: residual life time not sufficient).
- If the battery has not enough charge to continue the logging activity, the red or green LED will blink for 2 seconds (the green one in case of no alarms, the red one in case of some alarms).

Table 1. Alarm Indicator

	NO ALARM	ALARM
Temperature Status	Green	Red
Battery Status	No flashing	Flashing

If the BE bit is 1 (Start/stop function active), in addition to the behaviour described above, the logging activity start can be performed as follows:

- Hold down the button.
- Wait until the green LED lights and the red LED start blinking.
- Release and press again the button within 5 seconds to confirm the command.
- As the command is accepted, the green LED will stay lit for 15 seconds.
- The acquisition is started.

If the SD bit is 0, the logging activity stop is also allowed as follows:

- Hold down the button.
- Wait until the red LED lights and the green LED start blinking.

- Release and press again the button within 5 seconds to confirm the command.
- As the command is accepted, the green LED will stay lit for 15 seconds.
- The acquisition is stopped.

Histogram Functionality Description

The Processor of DLR-TL001 is dedicated to acquire & store, check, perform calculation, format data and output the most urgent & significant items to a reader, starting from the temperatures sampled in a very flexible and programmable way. Statistics, Means, Alarms, are processed by using an 'HISTOGRAM BINS DATA SCHEME" that reduces the active current consumption time.

The DLR-TL001 tag allows to define up to 16 different histograms bins. The user can decide the upper and lower temperature limits for each bin: the lower limit of each bin is equal to the upper limit of the previous bin, while the upper limit can be defined by the user.

The sample time is programmable for each histogram (and can be even modified inside it under specific precision needs), the relative threshold alarms can be enabled/disabled independently.

Histogram bins configuration allows also to control the storage of the samples inside the logging memory: for each bin the user can choose to store or not the temperature value and its time stamp in the memory.

This allows a better handling of long term deliveries by memory saving. Time stamps storage helps to keep track of the chronological sequences.



NOTE

For more details and examples on the DLR-TL001 histogram, please refer to the Logger's Product Reference Guide (PRG).

Mean Kinetic Temperature Calculation

The Mean Kinetic Temperature (MKT) is a simplified way of expressing the overall effect of temperature fluctuations during storage, transit and shipment of perishable goods. DLR-TL001 tag updates the MKT at each temperature

sample. The MKT function can be enabled/disabled. The following formula gives the MKT:

$$MKT = \frac{\frac{\Delta H}{R}}{-\ln \left(\frac{e^{\frac{-\Delta H}{RT_1}} + e^{\frac{-\Delta H}{RT_2}} + \dots + e^{\frac{-\Delta H}{RT_n}}}{n} \right)}$$

Where ΔH is the MKT activation energy constant expressed in J/mol, R is the universal gas constant, n is the number of the samples and Tn is the temperature of the different samples expressed in °K.

The user can set a threshold value for the MKT; if the MKT exceeds the threshold, DLR-TL001 Tag generates an alarm setting MKT_ALARM bit to 1 in the STATUS register.

Remaining Shelf Life Calculation

Shelf Life is the length of time that perishable items are given before they are considered unsuitable for sale or consumption. As well as the MKT, the remaining Shelf Life calculation is useful to monitor the status of the protected goods during the shipment. The DLR-TL001 calculates the remaining Shelf Life at each sampling time. Shelf Life time can be enabled/disabled.

The remaining Shelf Life (hours) is calculated with a formula that is described in the Product Reference Guide or in the Programming Manual, in the 'Shelf Life" dedicated chapter.

Battery Measurement and Behaviour

The DLR-TL001 tag includes a battery measurement circuitry that allows to control the battery charge level.

Four battery charge levels are defined: Full (3), Normal (2), Low (1), Empty (0); values can be obtained by reading two dedicated BITS in the STATUS register. The DLR-TL001 tag behaves normally when the battery is at the Full or Normal battery level, while it is automatically put in Sleep state when the level reaches the Low value.

When the battery level status is Low (1) or Empty (0) the battery level is considered critical, so the condition is reported by the manual interface as described in the relevant paragraph.

DLR-TL001 Memory Description

Address Space

The DLR-TL001 tag implements a standard Gen2 memory map; it has 4 memory banks: **RESERVED**, **EPC**, **TID** and **USER**. Below is a brief explanation of the memory banks' content (all the addresses are specified as 16-bit word bounded):

EPC

This bank contains a 16 bit CRC-16 and a 16 bit PC field, according to the standard, and additional 496 bits for EPC storing. The EPC bank contains the EPC of the DLR-TL001 product, that is composed by the Datalogic company prefix, the DLR-TL001 object type and a serial number. The EPC is formatted as a SGTIN-96 code.

TID

This bank contains the Class Identifier, the Mask-Designer Identifier, the Model Number of the chip, as requested by the standard, plus a 32 bit long Serial Number (see below for details) and the assembly and chip revision. Total size of the TID field is 64 bits. The TID memory bank contains also a 32 bit SAM field used to store the address of the sensor characteristics table, as defined by the ISO18000 6REV1 draft standard, and additional 110 bytes for user purposes. The TID and SAM fields are 'permalocked' by the manufacturer while the additional user space is not locked by default, but it can be locked using the standard Gen2 lock mechanism.

Table 2. TID memory bank structure

Free memory space		3C _h
.....		
Free memory space		0A _h
Assembly Revision		09 _h
Chip Revision		08 _h
RFU (Reserved for Future Use)		06 _h -07 _h
SAM (31...16)		05 _h
SAM (15...0)		04 _h
Serial Number (31 ... 16)		03 _h
Serial Number (15 ... 0)		02 _h
Model Number (11 ... 0) 000000000110 _b	MDID (11 ... 8) 0000 _b	01 _h
Mask Designer ID(7...0) 00010010 _b	Class ID 11100010 _b	00 _h

RESERVED

This bank contains the 32 bit Kill password and the 32 bit Access password according to the EPC Class 1 Gen 2 standard. The RESERVED memory bank contains additional 56 bytes for user purposes. The locking mechanism of the user data field in a RESERVED memory bank is linked to the locking of the Access password field (i.e. user data is locked when the access password is locked). Data stored in these 56 bytes are also protected from reading, like the password fields, when locked.

Table 3. RESERVED memory bank structure

Free memory space		1F _h
.....		
Free memory space		04 _h
Access Password (31 ... 16)		03 _h
Access Password (15... 0)		02 _h
Kill Password (31 ... 16)		01 _h
Kill Password (15... 0)		00 _h

USER MEMORY

This bank contains all the configuration registers and the logging memory. The total memory bank's size is 8 Kbyte (see next chapter for details), 220 bytes are needed for the configuration and status register, 56 bytes are free for user purposes and 7914 are allocated for the log area.

User Memory map

Here is reported the beginning and the tail of the **USER MEMORY** table, that contains all the configuration registers and the logging memory.

You can find the full table in the Product Reference Guide and in the Programming Manual.

The first 8 registers in the **Table 4** below the main general ones for the Logger application.

Table 4. User Memory Map

REGISTER	ADDRESS	OP.	DEFAULT
CONTROL	0x0A	RW	0x0010
SAMPLING_DELAY	0x0B	RW	0x0E10
INIT_DATE_L	0x0C	RW	0x0000
INIT_DATE_H	0x0D	RW	0x0000
ETA_L	0x0E	RW	0x0000
ETA_H	0x0F	RW	0x0000
BIN_ENABLE	0x10	RW	0x0001
.....	--
STATUS	0x51	RO	--
USER_AREA_0	0x6E	RW	--
USER_AREA_1	0x6F	RW	--
.....	--
USER_AREA_27	0x89	RW	--
LOG_AREA_0	0x8A	RO	--
.....	--
LOG_AREA_3956	0xFFE	RO	--

Two Main Register Descriptions

The user can get a detailed description of the Registers In the Product Reference Guide and in the Programming Manual.

Here below, only the **CONTROL** and **STATUS** Registers will be described at Bit/ Flag level to improve the reading of this quick guide.

The **CONTROL** Register's 16 bits are the following:

0 - RST (RW) - Reset bit: used to erase all the log memory and reset all the memory pointers and counters included the histogram bins.

1 - BE (RW) - Button_Enable bit: if 1, the DLR-TL001 button can be used to start and to stop the logging activity.

2 - LE (RW) - Logging_Enable bit: if 1, the logging activity is enabled.

3 - DE (RW) - Delay_Enable bit: If 1, the first sample's acquisition is given a preset number of seconds after logging starts.

4 - RFSL (RW) - RF_Sensitivity_Level: used to set the sensitivity level of radio freq. front-end. 3 levels: 3 = max, 1 = min. Default value 1.

5 - MKTE (RW) - Mean_Kinetic_Enable bit: if 1, the MKT calculation is enabled. Default value is 0.

6 - ARRE (RW) - Arrhenius_Enable bit: if 1, the calculation of the remaining Shelf Life is enabled. Default value is 0.

11 - SD (RW) - Stop_Disable bit: if 1, the DLR-TL001 button cannot be used to stop the logging activity. Default value is 0.

8 to 10 & 12 to 15 Bits are **RFU (RW)** bits (**R**eserved for **F**uture **U**se).

The **STATUS** Register's 16 bits are the following:

0 - BAT_LSBIT (RO):

1 - BAT_MSBIT (RO): Bits 0 & 1 codify the Battery Level Status

2 - MEMFULL (RO): flag a full memory condition.
DLR-TL-001 is put in Sleep Mode automatically

3 - ETA_ALARM (RO): set if ETA delay is exceeded.

4 - BIN_ALARM (RO): histograms Alarm. Set if at least one threshold is exceeded.

5 - MKT_ALARM (RO): set if the Mean Kinetics Temperature is greater than the Mean Kinetic Threshold Temperature.

6 - SHL_ALARM (RO): remaining shelf life is smaller than threshold.

6 to 15 Bits – RFU: (Reserved for Future Use).

DLR-TL001 Specifications

Technical Specifications

Item	Description
Physical Characteristics	
Reader Dimensions	10.7 x 10.7 x 6.60 cm ³ / 4.2 x 4.2 x 2.6 in ³ (WLH)
Weight	24 g / 0.84 oz
Electrical Characteristics	
Tag Type (Powering)	Semipassive - Internal Battery for measures. - Passive antenna (reflecting)
Battery Type	Poly-carbonmonofluoride lithium batteries Model Panasonic BR2032
Battery Life	1 year MIN
RFID - Tag Link	
Type	UHF – RFID (Passive Link - Reflecting)
Antenna	Integrated linear
Standard Compliance	ISO 18000-6C/EPC C1 G2
Frequency Range	865.60 - 928.00 MHz
Reading Range	Up to 10 m / 394 in(ches) in air @ 2W ERP Reader
Temperature Logging Characteristics	
Temperature Accuracy	±0.5°C typical
Time Accuracy	<0.01% error
Data Points	4000
Memory Capacity	4k samples (8 Kbyte)
Available Memory	Up to 512 bits in EPC bank, up to 512 bits in User Memory bank
Monitoring Delay	Up to 18 hours
Alarms	Multiple user-configurable High & Low Temp. alarm, ETA alarm, MKT alarm, Shelf Life alarm

Item	Description
Shelf Life Prediction	Calculation as per Arrhenius kinetic model: Customer time-temper. Dependency Set
Shelf Life Monitoring	Provides Remaining Shelf Life info at check points with RFID reader or manual interface
User Environment	
Enclosure Protection	IP67
Enclosure Material	PVC Tecnovil code: 21TV306TRS000000 ^a
Operating Temperature	-10°C to 60°C / 14°F to 140°F
Storage Temperature	-10°C to 60°C / 14°F to 140°F
ESD	Air ± 16kV

a See. Notes, Conformance & Compliance in the Product Reference Guide

Air Link Protocol Characteristic (Physical Layer)

In general, the DLR-TL001 tag satisfies the EPCglobal C1G2 physical layer protocol specification, with the exception of the following points:

- **Reader to tag data rates:** the interrogator can only use Tari value of 25 μsec . Tari values of 12.5 μsec and 6.25 μsec are not supported.
- **Tag to reader encoding:** the encoding format, selected in response to the interrogator commands, can be either FMO or Miller (M=4) as specified in [RD5], chapter 6.3.1.3.2 of. Miller data encoding with M=2 and M=8 are not supported.
- **Tag to reader data rates:** the DLR-TL001 tag supports tag to interrogator data rates and link frequencies as specified in the following table:

Table 5. Tag to reader data rates

Divide Ratio	TRcal ^a	Link Frequency	Encoding Type
8	200 μsec	40 kHz	FMO
64/3	66.6 μsec	320 kHz	Miller M=4
64/3	83.3 μsec	256 kHz	Miller M=4
64/3	85.3 μsec	250 kHz	Miller M=4

a TRcal is the Tag to Interrogator calibration time.

- **Commands:** all the EPC C1G2 mandatory commands are supported as well as the optional Access command. For more details see the Product Reference Guide (PRG).

Mechanical Specification

Measures are given in millimetres.

Figure 2.

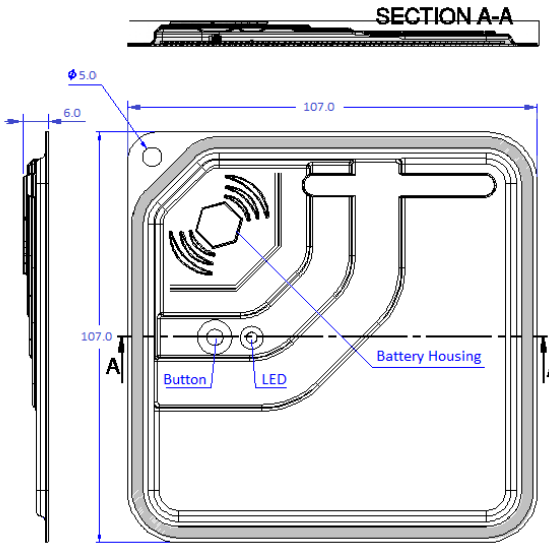

DLR-TL001 Temperature Measurement Traceability

The **DLR-TL001** temperature loggers are individually tested before release to verify operational functionality and product performance.

In addition, the DLR-TL001 loggers are individually calibrated for temperature accuracy measurement.

The temperature accuracy verification processes are in compliance with SIT/Tec-001/01 and are traceable to the International System of Units (SI) through the Italian Metrological Research National Institute (I.N.R.I.M. Istit. Naz. di Ricerca Metrol.) and Italian Calibration Service (SIT Serv. Taratura Italia).

Datalogic Limited Factory Warranty

Warranty Coverage

Datalogic warrants to Customer that Datalogic's products will be free from defects in materials and workmanship for a period of 3 months from product shipment. Datalogic hardware products are warranted against defects in material and workmanship under normal and proper use. The liability of Datalogic under this warranty is limited to furnishing the labor and parts necessary to remedy any defect covered by this warranty and restore the product to its normal operating condition. Repair or replacement of product during the warranty does not extend the original warranty term. Products are sold on the basis of specifications applicable at the time of manufacture and Datalogic has no obligation to modify or update products once sold.

If Datalogic determines that a product has defects in material or workmanship, Datalogic shall, at its sole option repair or replace the product without additional charge for parts and labor, or credit or refund the defective products duly returned to Datalogic. To perform repairs, Datalogic may use new or reconditioned parts, components, subassemblies or products that have been tested as meeting applicable specifications for equivalent new material and products. Customer will allow Datalogic to scrap all parts removed from the repaired product. The warranty period shall extend from the date of shipment from Datalogic for the duration published by Datalogic for the product at the time of purchase (Warranty period). Datalogic warrants repaired hardware devices against defects in workmanship and materials on the repaired assembly for a 90 day period starting from the date of shipment of the repaired product from Datalogic or until the expiration of the original warranty period, whichever is longer. Datalogic does not guarantee, and it is not responsible for, the maintenance of, damage to, or loss of configurations, data, and applications on the repaired units and at its sole discretion can return the units in the "factory default" configuration or with any software or firmware update available at the time of the repair (other than the firmware or software installed during the manufacture of the product). Customer accepts responsibility to maintain a back up copy of its software and data.

Warranty Claims Process

In order to obtain service under the Factory Warranty, Customer must notify Datalogic of the claimed defect before the expiration of the applicable Warranty period and obtain from Datalogic a return authorization number (RMA) for return of the product to a designated Datalogic service center. If Datalogic determines Customer's claim is valid, Datalogic will repair or replace product without additional charge for parts and labor. Customer shall be responsible for packaging and shipping the product to the designated Datalogic service center, with shipping charges prepaid. Datalogic shall pay for the return of the product to Customer if the shipment is to a location within the country in which the Datalogic service center is located. Customer shall be responsible for paying all shipping charges, duties, taxes, and any other

charges for products returned to any other locations. Failure to follow the applicable RMA policy, may result in a processing fee. Customer shall be responsible for return shipment expenses for products which Datalogic, at its sole discretion, determines are not defective or eligible for warranty repair.

Warranty Exclusions

The Datalogic Factory Warranty shall not apply to:

- (i) any product which has been damaged, modified, altered, repaired or upgraded by other than Datalogic service personnel or its authorized representatives;
- (ii) any claimed defect, failure or damage which Datalogic determines was caused by faulty operations, improper use, abuse, misuse, wear and tear, negligence, improper storage or use of parts or accessories not approved or supplied by Datalogic;
- (iii) any claimed defect or damage caused by the use of product with any other instrument, equipment or apparatus;
- (iv) any claimed defect or damage caused by the failure to provide proper maintenance, including but not limited to cleaning the upper window in accordance with product manual;
- (v) any defect or damage caused by natural or man-made disaster such as but not limited to fire, water damage, floods, other natural disasters, vandalism or abusive events that would cause internal and external component damage or destruction of the whole unit, consumable items;
- (vi) any damage or malfunctioning caused by non-restoring action as for example firmware or software upgrades, software or hardware reconfigurations etc.;
- (vii) the replacement of upper window/cartridge due to scratching, stains or other degradation and/or
- (viii) any consumable or equivalent (e.g., cables, power supply, batteries, keypads, touch screen, triggers etc.).

No Assignment

Customer may not assign or otherwise transfer its rights or obligations under this warranty except to a purchaser or transferee of product. No attempted assignment or transfer in violation of this provision shall be valid or binding upon Datalogic.

DATALOGIC'S LIMITED WARRANTY IS IN LIEU OF ALL OTHER WARRANTIES, EXPRESS OR IMPLIED, ORAL OR WRITTEN, STATUTORY OR OTHERWISE, INCLUDING, WITHOUT LIMITATION, ANY IMPLIED WARRANTIES OF MERCHANTABILITY, FITNESS FOR A PARTICULAR PURPOSE, OR NONINFRINGEMENT. DATALOGIC SHALL NOT BE LIABLE FOR ANY DAMAGES SUSTAINED BY CUSTOMER ARISING FROM DELAYS IN THE REPLACEMENT OR REPAIR OF PRODUCTS UNDER THE ABOVE. THE REMEDY SET FORTH IN THIS WARRANTY STATEMENT IS THE CUSTOMER'S SOLE AND EXCLUSIVE REMEDY FOR WARRANTY CLAIMS. UNDER NO CIRCUMSTANCES WILL DATALOGIC BE LIABLE TO CUSTOMER OR ANY THIRD PARTY FOR ANY LOST PROFITS, OR ANY INCIDENTAL, CONSEQUENTIAL INDIRECT, SPECIAL OR CONTINGENT DAMAGES REGARDLESS OF WHETHER DATALOGIC HAD ADVANCE

NOTICE OF THE POSSIBILITY OF SUCH DAMAGES.

Risk of Loss

Customer shall bear risk of loss or damage for product in transit to Datalogic. Datalogic shall assume risk of loss or damage for product in Datalogic's possession. In the absence of specific written instructions for the return of product to Customer, Datalogic will select the carrier, but Datalogic shall not thereby assume any liability in connection with the return shipment.

Services and Support

Datalogic provides several services as well as technical support through its website. Log on to www.datalogic.com and click on the links indicated for further information.

Products

Search through the links to arrive at your product page where you can download specific **Manuals** and **Software & Utilities**.

Service & Support

- **Technical Support** - Product documentation and programming guides and Technical Support Department in the world
- **Service Programs** - Warranty Extensions and Maintenance Agreements
- **Repair Services** - Flat Rate Repairs and Return Material Authorization (RMA) Repairs
- **Downloads** – Manuals & Documentation, Data Sheets, Product Catalogues, etc.

Contact Us

- Information Request Form and Sales & Service Network

NOTES



www.datalogic.com

©2016-2017 Datalogic S.p.A. and/or its affiliates. All rights reserved. Datalogic and the Datalogic logo are registered trademarks of Datalogic S.p.A. in many countries, including the U.S. and the E.U.

Datalogic S.r.l.

Via San Vitalino 13 | Calderara di Reno (BO) | 40012 | Italy
Telephone: +39 051 3147011 | Fax: +39 051 3147205



820076914

(Rev D)

March 2017