



# **M-Series Processor and Camera Guide**

Publication Number 843-0138 (Rev AM)

---

## Disclaimer

Datalogic Automation Inc. makes no representations or warranties for merchantability or fitness for any particular purpose, regarding Datalogic's software or hardware. Datalogic Automation Inc. shall not be liable for errors contained herein or for incidental or consequential damages in connection with the furnishing, performance, or use of this publication or its contents.

Datalogic Automation, Inc. reserves the right to revise this publication from time to time and to make changes in the content hereof without obligation to notify any person of such revision or changes.

Under the copyright laws, neither this publication nor the software may be copied, photocopied, reproduced, or reduced to any electronic medium or machine-readable form, in whole or in part, without the prior written consent of Datalogic Automation Inc.

**Telephone:** 952-996-9500  
**Facsimile:** 952-996-9501  
**Web site:** <http://www.datalogic.com>  
**E-Mail:** [mvsupport@datalogic.com](mailto:mvsupport@datalogic.com)

Impact, Vision Program Manager, VPM, Control Panel Manager, and CPM are trademarks of Datalogic Automation Inc. Microsoft Windows is a trademark of Microsoft Corporation. Java is a trademark of Sun Microsystems, Inc. JAI is a trademark of JAI A/S. Basler is a trademark of Basler AG. Dalsa is a trademark of Teledyne Dalsa.

Datalogic and the Datalogic logo are registered trademarks of Datalogic S.p.A. in many countries, including the U.S.A. and the E.U.

## CE Compliance

Warning: This is a Class A product. In a domestic environment this product may cause radio interference in which case the user may be required to take adequate measures.

## FCC Compliance

This equipment has been tested and found to comply with the limits for a Class A digital device, pursuant to part 15 of the FCC Rules. These limits are designed to provide reasonable protection against harmful interference when the equipment is operated in a commercial environment. This equipment generates, uses, and can radiate radio frequency energy and, if not installed and used in accordance with the instruction manual, may cause harmful interference to radio communications. Operation of this equipment in a residential area is likely to cause harmful interference in which case the user will be required to correct the interference at the user's own expense.

Copyright © 2010-2013 Datalogic Automation Inc. All Rights Reserved

---

## Technical Support

If you have technical questions about the operation of any Datalogic Automation Inc. product, contact your distributor or Datalogic Automation Inc. Please have the following information available before you call:

- The version number of Impact Software Suite you are running. To find it, click the About icon in the main toolbar.
- The model and serial numbers of the devices you are using.

# T A B L E O F C O N T E N T S

## Chapter 1: When Your System Arrives

System Factory Setup .....	1-1
Hardware Components .....	1-1
Safety Precautions .....	1-2
Processor Specifications .....	1-3
Setting Up the System .....	1-3
MX20 and MX40 Front Panel Connections .....	1-5
MX20 and MX40 Rear Panel Connections .....	1-6
MX80 Front Panel Connections .....	1-7
MX80 Rear Panel Connections .....	1-8
Preventive Maintenance .....	1-9
Before You Call .....	1-9

## Chapter 2: Basic Hardware Components

MX20 and MX40 Processors Views and Dimensions .....	2-1
MX80 Processor Views and Dimensions .....	2-2
Processor Installation .....	2-3
Safety Instructions .....	2-3
Flat Surface Mounting .....	2-4
DIN Rail Mounting .....	2-4
MX20 and MX40 Status Lights .....	2-7
MX80 Status Lights .....	2-8
MX20 and MX40 Processor Power Supply Connection .....	2-9
MX80 Processor Power Supply Connection .....	2-10

## Chapter 3: M-Series Cameras

Introduction .....	3-1
Safety Precautions .....	3-1
Before you install the camera .....	3-2
Camera Dimensions .....	3-3
M1xx Camera Dimensions .....	3-3
M2xx Camera Dimensions .....	3-4
M3xx Camera Dimensions .....	3-5
M5xx Camera Dimensions .....	3-6
Mounting the Camera .....	3-7
Connecting the Camera .....	3-8
M1xx Camera Connection .....	3-8
M2xx and M3xx Camera Connection .....	3-12
M5xx Camera Connection .....	3-16
Third-party Cameras .....	3-20
JAI Cameras .....	3-20
Basler Cameras .....	3-28
Smartek Cameras .....	3-33
SVS-Vistek Cameras .....	3-38
Dalsa Cameras .....	3-39
Camera Specifications .....	3-43
M1xx, M1xxC .....	3-43
M100, M100C .....	3-43
M110, M110C .....	3-44
M115, M115C .....	3-45
M125, M125C .....	3-46
M150, M150C .....	3-47
M180, M180C .....	3-48
M190, M190C .....	3-49
M195, M195C .....	3-50
M2xx, M2xx-RA, M2xxC, M2xxC-RA .....	3-51
M200 line .....	3-51
M202 line .....	3-52

M210 line.....	3-53
M230 line.....	3-54
M250 line.....	3-55
M270 line.....	3-56
M290 line.....	3-57
M295 line.....	3-58
M3xx, M3xx-RA, M3xxC, M3xxC-RA .....	3-59
M300 line.....	3-59
M330 line.....	3-60
M350 line.....	3-61
M390 line.....	3-62
M5xx.....	3-63
M510 .....	3-63
M520 .....	3-64
M530 .....	3-64
M540 .....	3-64
M550 .....	3-65
M560 .....	3-65
<b>Chapter 4: Processor I/O Reference</b>	
Processor I/O Connection .....	4-1
Processor Inputs .....	4-1
Input Wiring .....	4-2
General Purpose Input Circuit (Sinking).....	4-2
General Purpose Input Circuit (Sourcing) .....	4-2
Processor Outputs.....	4-3
Pullup Jumpers to Enable Sourcing .....	4-3
Output Wiring .....	4-4
General Purpose Output Circuit (Sinking).....	4-4
General Purpose Output Circuit (Sourcing) .....	4-5
<b>Chapter 5: Cable Reference</b>	
Cables .....	5-1
Processor Ethernet .....	5-1
Processor Input/Output .....	5-1
Processor Power Supply Connector .....	5-1
MX20 and MX40 Processor Serial Port .....	5-2
MX80 Processor Serial Ports .....	5-2
MX40 VGA Connector.....	5-2
MX80 DVI-I Video Connector .....	5-3
M1xx Camera .....	5-3
M2xx and M3xx Cameras .....	5-3
M5xx Camera .....	5-3
<b>Chapter 6: Appendix</b>	
Using Older Terminal Blocks.....	6-1
M1xx Camera Connection (Older Terminal Blocks).....	6-1
M2xx and M3xx Camera Connection (Older Terminal Blocks) .....	6-6
M5xx Camera Connection (Older Terminal Blocks).....	6-10
Third-party Cameras (Older Terminal Blocks).....	6-15
JAI Cameras (Older Terminal Blocks).....	6-16
Basler Cameras (Older Terminal Blocks).....	6-19
SVS-Vistek Cameras (Older Terminal Blocks).....	6-23
Processor Input/Output (Older Terminal Blocks) .....	6-24
Processor Older I/O Terminal Block.....	6-26

# When Your System Arrives

Thank you for purchasing an M-Series embedded machine vision system (M-Series Processor). *Please read the instructions in this document before starting your system setup.*

This manual explains the various parts of the M-Series system hardware, including the system inputs and outputs available to integrate your system into a production line. This manual covers the entire line of M-Series processors. Sections that apply to a specific model number are indicated.

When your system arrives, check the shipping cartons for wrinkled or damaged corners, holes through the cardboard, or other signs of rough handling or abuse. If you find any signs of damage, ask the delivery service to make a note on the delivery receipt describing the damage.

Carefully remove the system unit, cameras, cabling, and accessories from the shipping package. Place all equipment you unpack on a table and inspect each item. Report any damage to the carrier immediately. Save all packing materials so you can repack the shipment in case you need to move or ship it.

---

**Temperature precautions:** If your system arrives in very cold or hot weather, allow all the equipment to reach room temperature before plugging it in. Exposing a cold device to a warm room causes condensation that could damage the system if power is applied too soon. If condensation forms, wait for it to dry completely.

---

---

## System Factory Setup

Before we shipped your M-Series vision system, we did the following:

- Ran the installation and setup program and specified a default software and hardware configuration. See page 1-3 for more information about setting up the hardware. Refer to the Impact Reference Guide for software configuration information.
- Set the default Internet Protocol (IP) address and a default IP Mask values for the cameras and the M-Series Processor.

## Hardware Components

The major hardware components of the system are the M-Series Processor, camera, power supply, and cables.

---

NOTE: The M40 model number was changed to MX40 for consistency. All specifications and parameters are the same.

---

- MX20 M-Series Processor with 1 camera: 661-0405-MX20-1
- MX20 M-Series Processor with 2 cameras: 661-0405-MX20-2
- MX40 M-Series Processor with 1 camera: 661-0396-M40-1
- MX40 M-Series Processor with 2 cameras: 661-0396-M40-2

- MX40 M-Series Processor with 3 cameras: 661-0396-M40-3
- MX40 M-Series Processor with 4 cameras: 661-0396-M40-4
- MX80 M-Series Processor with 1 camera: 661-0404-MX80-1
- MX80 M-Series Processor with 2 cameras: 661-0404-MX80-2
- MX80 M-Series Processor with 3 cameras: 661-0404-MX80-3
- MX80 M-Series Processor with 4 cameras: 661-0404-MX80-4
- For details about cameras, see “M-Series Cameras” on page 3-1
- For details about M-Series cables, see “Cables” on page 5-1

To configure a camera, connect a monitor and keyboard to the appropriate M-Series Processor port, then connect the camera’s Ethernet connector to the appropriate M-Series camera port. See M-Series Cameras on page 3-1 for details.

An optional power supply is available for M-Series Processors. If you provide your own, it must supply 10 to 30VDC with a safe operating ambient temperature range of 0° to +55° C (+32° to +131° F).

This equipment is to be powered by a Listed power supply for the U.S. and Canada, or a power supply that meets the requirements for use where either IEC 60950 or EN60950 is applicable.

## Safety Precautions



**Warning:** There are no user-serviceable parts inside the hardware. To avoid electrical shock, never open the case. Opening the case or removing the tamper-proof sticker will void the product warranty.

---



**Attention:** Il n'ya pas de pièces réparables par l'utilisateur à l'intérieur du matériel. Pour éviter un choc électrique, n'ouvrez jamais le boîtier. L'ouverture du boîtier ou de retirer l'étiquette inviolable annulera la garantie du produit.

---



**Warning:** See Mounting Warning on page 2-3.

---

1. Read all of the following instructions before setting up your system. **Save this document for later use.**
2. Follow all warnings and instructions in this manual and in other user guides shipped with your hardware components.
3. To avoid damage to the vision system and its components, **never** plug in or unplug a cable when the power is on. Always turn off the power supply before you make cable changes.
4. Never use the system if a power cable has been damaged. Do not allow anything to rest on a power cable and keep them away from traffic.
5. The air inlets and exhausts on the top and sides of the unit are for ventilation. Do not block or cover these openings or insert anything into these openings. Metal screen filters may be installed in the fan exhausts.
6. Do not expose the vision system to moisture, rain, or snow, and do not use it near water. If a component gets wet unplug it.

7. To avoid injury, never open the case. Opening the case or removing the tamper-proof sticker will void the product warranty.



**Service Personnel Only - Caution:** Risk of explosion if battery is replaced by an incorrect type. Dispose of used batteries according to battery maker's instructions.

## Processor Specifications

This section lists the general operating specifications for the M-Series Processor. More detailed specifications are listed in other appropriate sections of this manual. Each of the M-Series cameras has different operating specifications. See "M-Series Cameras" on page 3-1 for details.

Processor Operating Environment		
Model	MX20** and MX40	MX80
Dimensions	7.8 w x 3.3 h x 6.5 d (in) 200 w x 85 h x 165 d (mm)	9.06 w x 3.23 h x 8.11 d (in) 230 w x 82 h X 206 d (mm)
Weight	4.8 lb. (2.16 kg)	6.61 lb. (3 kg)
Input Power*	10 to 30VDC $\overline{\text{---}}$ , Min 3.5A	10 to 30VDC $\overline{\text{---}}$ , Min 5A
Temperature Humidity	0° to +55° C (+32° to +131° F) 0% to 90% (non-condensing)	0° to +55° C (+32° to +131° F) 0% to 90% (non-condensing)
Safety Compliance	CE/FCC, RoHs, IP30, UL (MX20 UL Pending)	CE/FCC, RoHs, IP30, UL
Minimum Software Version	MX20 - 10.5.0 MX40 - 10.0.0	10.4.0
Protection Class	IP50	IP50

\*Note: The MX20 and MX40 processors require approximately 3.5A @ 24VDC. We recommend using a 24 VDC power supply capable of providing 3.5A current. The M-Series processors run most efficiently at this voltage which is commonly used in many manufacturing environments. The MX80 processor requires approximately 5A @ 24VDC. We recommend using a 24 VDC power supply capable of providing 5A current. This voltage is commonly used in many manufacturing environments.

\*\*The MX20 processor can accommodate a maximum of two cameras. The maximum image size of each camera is two Megapixels. (The calculation is: maximum width in pixels \* maximum height in pixels < 2,500,000.)

## Setting Up the System

**WARNING:** To avoid damage to your unit, *never* plug in or unplug any cables when the unit power is on. Always turn off the power supply first before making any cable changes.

NOTE: When a new processor is powered on the first time, a monitor, keyboard, and mouse must be connected to the processor to approve the license agreement.

---

1. Familiarize yourself with the major system components that are shown in Chapter 3 of this manual.
2. Unpack and check all the equipment.
3. Mount the M-Series Processor and power supply in their desired positions. Mounting instructions are included in Chapter 3 of this manual. Make sure all vents have at least 1.5 inches (38.1 mm) of clearance for sufficient ventilation.
4. Connect the I/O cable, optional monitor, and optional keyboard to the M-Series Processor. Connect the I/O cable to the terminal block. When a new processor is powered on the first time, a monitor; keyboard; and mouse must be connected to the processor to approve the license agreement.
5. Mount the M-Series cameras, lighting, and optional power supplies. See “Mounting the Camera” on page 3-7. Connect the cameras to the Processor using the appropriate Ethernet cables. See “Connecting the Camera” on page 3-8.  
NOTE: Do not leave the camera imager uncovered. When you remove the lens cap, you must replace it with a lens.
6. You are ready to wire the hardware. See “Processor I/O Reference” on page 4-1 for details about input/output schematics for your M-Series system. Wiring specifications for all cables are described in “Cable Reference” on page 5-1.
7. Wire the M-Series cameras’ strobe, trigger, and power connections to the cameras’ terminal blocks. See “Connecting the Camera” on page 3-8.
8. Wire the M-Series Processor power connector to the optional power supply. Wire AC power to the power supply.
9. Connect the cables from the M-Series terminal blocks to their cameras.
10. Plug the power supplies into an appropriate *grounded* power source. To protect your system, we recommend using a surge protector.
11. Turn on the M-Series Processor power switch and the camera power supply.

---

**NOTE:** A default network IP mask and address were assigned to the M-Series Processor and Cameras at the factory. You will probably not need to change them unless there is a conflict with other devices on your network.

---

12. Start the Impact Software program Vision Program Manager and click on the Settings tab. Check your camera and lighting setup, calibrate the camera, configure your inspection parameters, then put the camera online. For more information about using Impact software, refer to the Impact Reference Guide.

If your system does not work when you are finished with the setup, review the instructions and diagrams to make sure you made all connections properly.

---

Please note that Datalogic cannot guarantee the performance of M-Series systems which have additional software installed on them, including, but not limited to, anti-virus and firewall software. Datalogic recommends that M-Series systems remain disconnected from networks that access the Internet in order to minimize security risks. Datalogic will attempt to support systems with antivirus software installed, but we cannot guarantee system performance.

---



# MX20 and MX40 Front Panel Connections

This illustration shows the connections for the MX20 and MX40 Processor’s front panel.

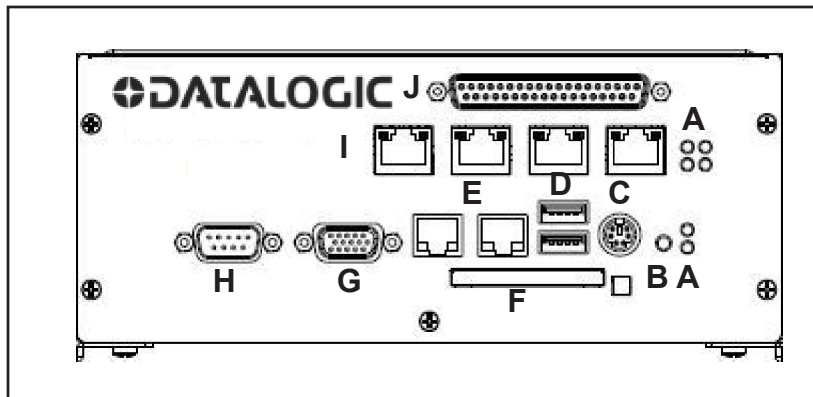

Symbol	Function
A	Status Lights (see “MX20 and MX40 Status Lights” on page 2-7)
B	Reset Button (Resets the Processor)
C	Keyboard and Mouse
D	USB Ports 2.0 (2)
E	LAN Ethernet Ports (2)
F	Compact Flash Socket (See Note below)
G	VGA Connector
H	Serial Port 1 - See “MX20 and MX40 Processor Serial Port” on page 5-2
I	M-Series Camera Connectors (CAM1-CAM4) MX20 has only 2 POE ports (CAM1-CAM2) Cable 606-0457-x
J	Digital I/O Connector - Cable 606-0675-xx with terminal block 661-0403

---

**Note:** If a Compact Flash card is present in the socket, it can be used for extended storage by the MX20 and MX40 processors. Do NOT insert or remove the card while the unit is powered on.

---

## MX20 and MX40 Rear Panel Connections

This illustration shows the connections for the MX20 and MX40 Processors' rear panel.

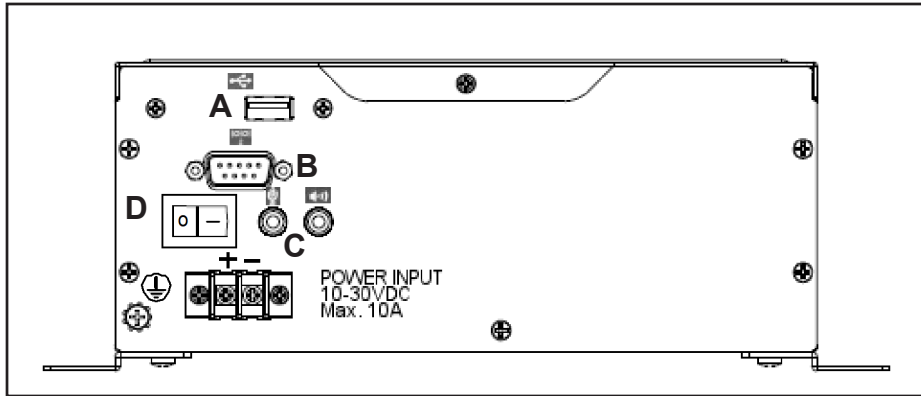

Symbol	Function
A	USB Port
B	Serial Port 2
C	Speaker and Microphone
D	Power Switch

# MX80 Front Panel Connections

This illustration shows the connections for the MX80 Processor’s front panel.

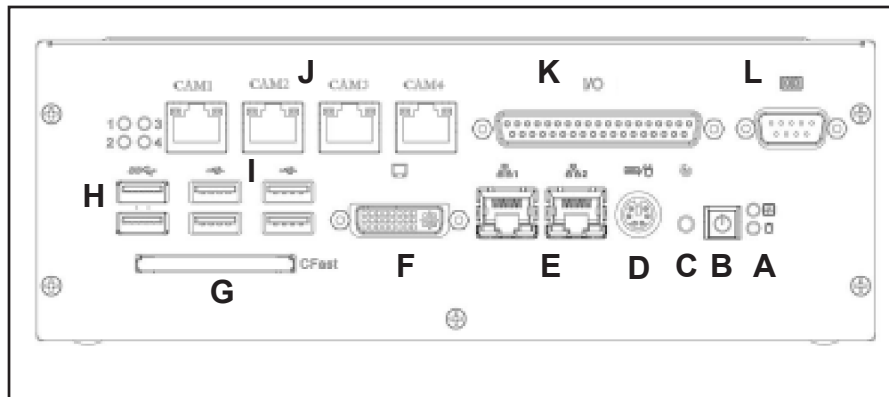

Symbol	Function
A	Status Lights (see “MX80 Status Lights” on page 2-8)
B	Power Button
C	Reset Button (Resets the processor)
D	Keyboard and Mouse
E	Gigabit Ethernet Ports (2)
F	DVI-I Video Connector (VGA Capable - ten meter cable maximum)
G	CFast Compact Flash Socket (See Note below)
H	USB 3.0 Ports (2)
I	USB 2.0 Ports (4)
J	M-Series Camera Connectors (CAM1 - CAM4) Cable 606-0457-x
K	Front Digital I/O Connector (I/O 1-16) Cable 606-0675-xx with terminal block 661-0403
L	Serial Port 1 (Com 5) See “MX80 Processor Serial Ports” on page 5-2

---

**Note:** If a Compact Flash card is present in the socket, it can be used for extended storage by the processor. Do NOT insert or remove the card while the unit is powered on.

---

# MX80 Rear Panel Connections

This illustration shows the connections for the MX80 Processor's rear panel.

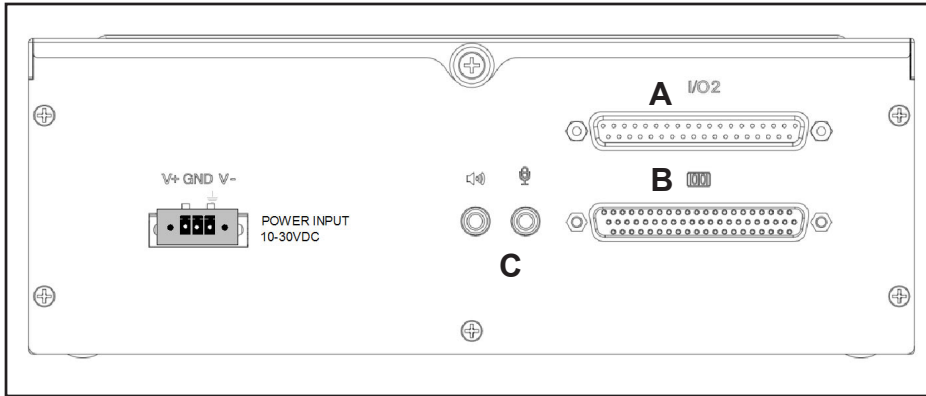

Symbol	Function
A	Do Not Use. (For future expansion)
B	Serial Ports 2-4 (COM 2-4)
C	Speaker and Microphone

---

## Preventive Maintenance

---



**Warning:** There are no user-serviceable parts inside the device. To avoid electrical shock, never open the case. Opening the case or removing the tamper-proof sticker will void the product warranty.

---



**Attention:** Il n'ya pas de pièces réparables par l'utilisateur à l'intérieur du matériel. Pour éviter un choc électrique, n'ouvrez jamais le boîtier. L'ouverture du boîtier ou de retirer l'étiquette inviolable annulera la garantie du produit.

---

This section contains tips to keep your system trouble-free and operating smoothly.

- Make sure there is at least 1.5 inches (38.1 mm) of clearance on the sides and top of the M-Series Processor.
- The M-Series Processor should be mounted securely in a vibration-free location.
- Keep the outside of the unit clean and free of oil and dust. You can clean the unit with a mild cleanser. *Do not* use an abrasive cleaner and *never* immerse the unit in water.
- Periodic cleaning of the air inlets and exhausts is highly recommended.
- Verify that all cable connections are correct and tight. Secure the cables to prevent accidents or damage to the device connectors.
- When you move the system, be careful that the movement does not loosen connections. After the system is moved, verify cable and power cord connections.
- Repair or replace frayed or damaged cables immediately.
- Do NOT attempt to clean the camera imager or imager cover. Do NOT spray the imager or imager cover with compressed air as this may leave spots.

## Before You Call

If you have a problem with your system, you can contact your distributor or call Datalogic Automation, Inc. Before calling, however, review the preceding maintenance checklist to ensure you are not overlooking an obvious reason for your problem.

When you call for support, be prepared to answer to the following questions:

- What are the model and serial numbers of the device you are using? The device model, serial, and part numbers are located on the back of the processor.
- Have you added, replaced, or reconfigured your hardware recently? This includes any changes to the camera or other components.
- What is the version number of Impact Software Suite you are running? To find it, look on the title bar of one of the Impact Software components.
- Have you updated or replaced any software on your client computer lately?



# Basic Hardware Components

## MX20 and MX40 Processors Views and Dimensions

This section shows specifications for the MX20 and MX40 Processors, including various views and dimensions.

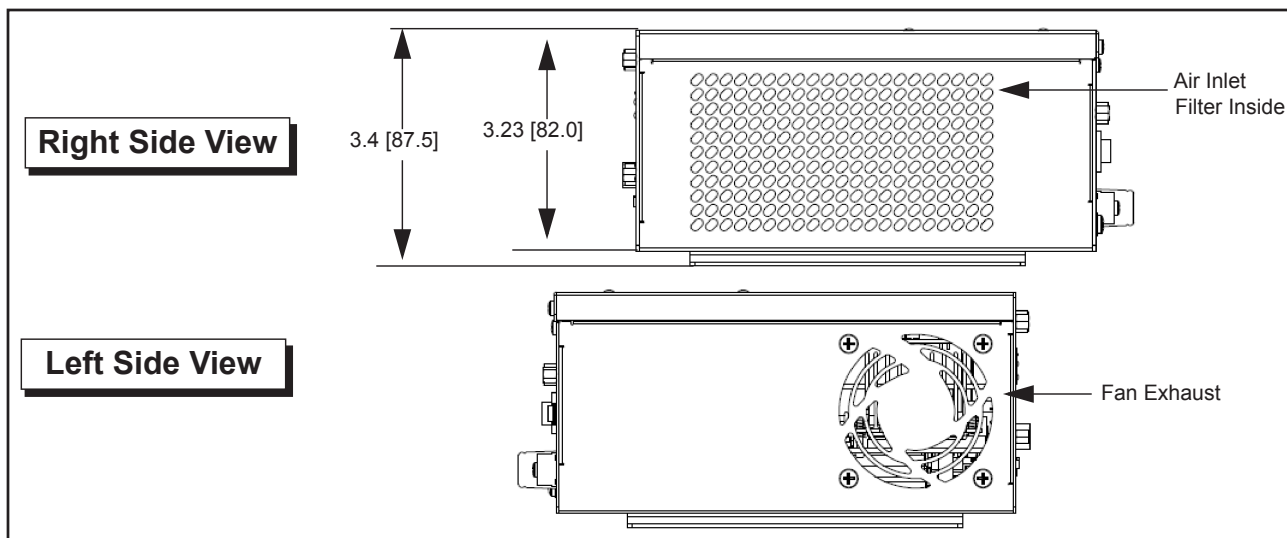
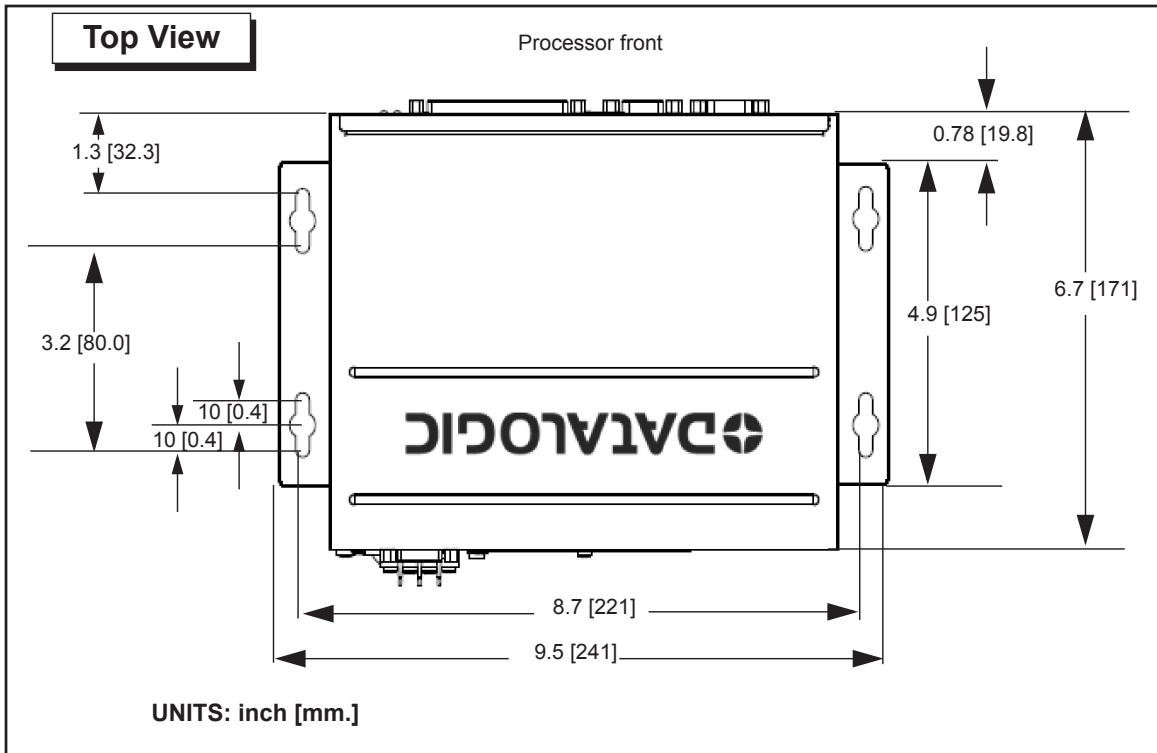

# MX80 Processor Views and Dimensions

This section shows specifications for the MX80 Processor, including various views and dimensions.

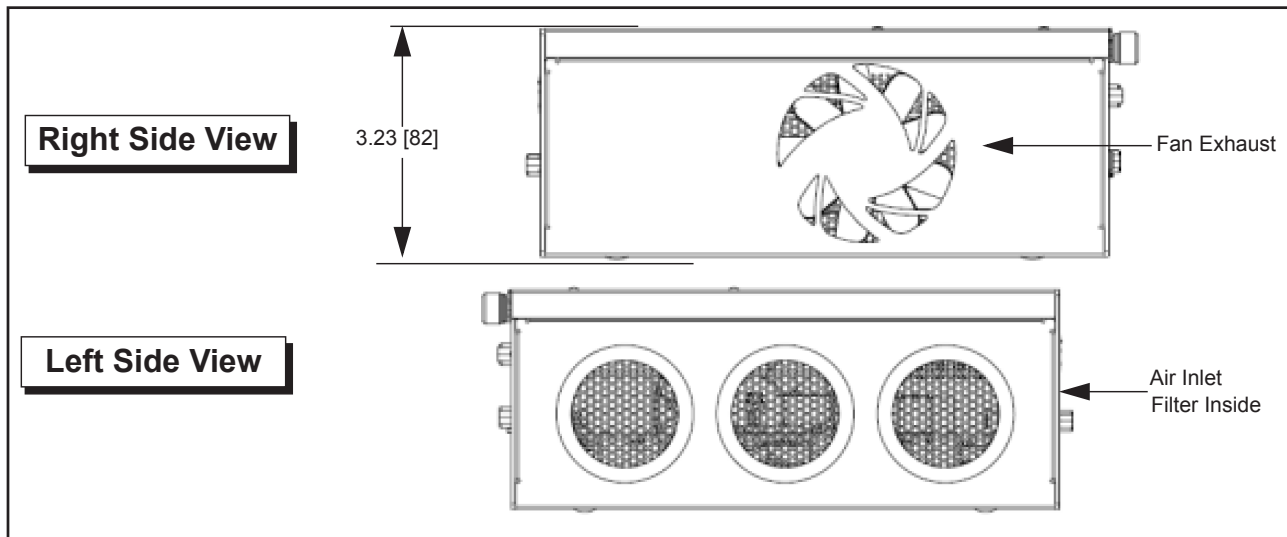
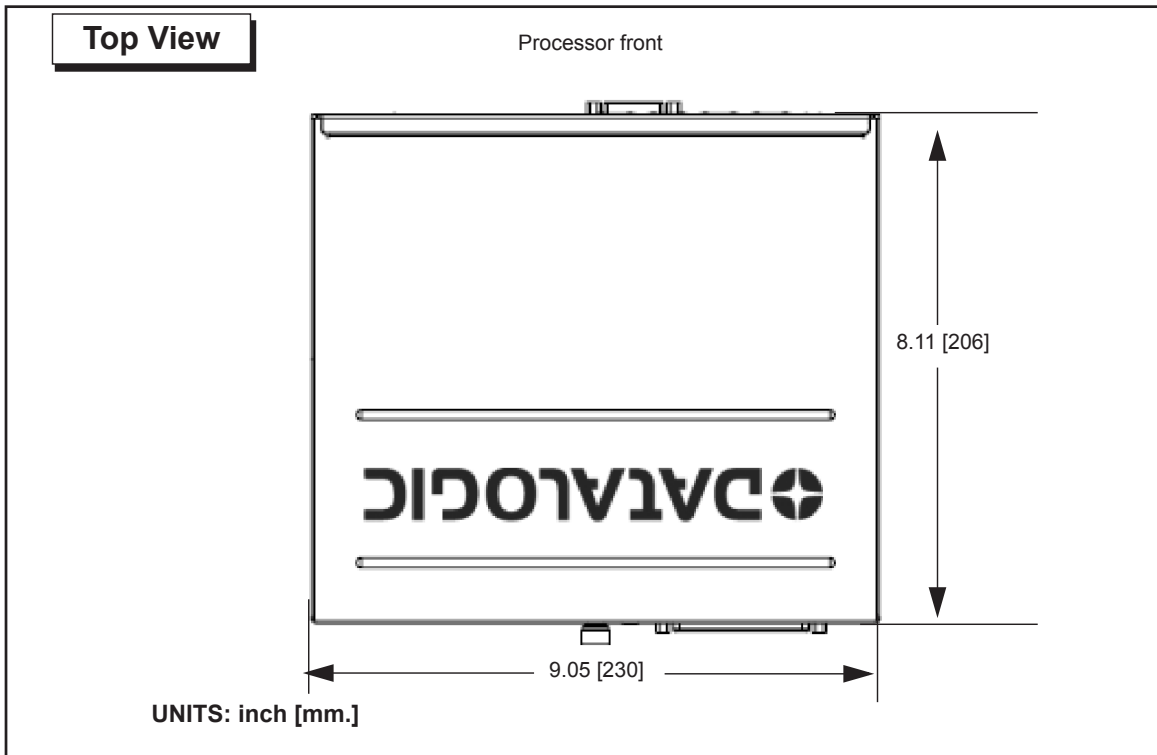



---

# Processor Installation

## Safety Instructions

---

 **Warning:** There are no user-serviceable parts inside the device. To avoid electrical shock, never open the case. Opening the case or removing the tamper-proof sticker will void the product warranty.

---

 Attention: Il n'ya pas de pièces réparables par l'utilisateur à l'intérieur du matériel. Pour éviter un choc électrique, n'ouvrez jamais le boîtier. L'ouverture du boîtier ou de retirer l'étiquette inviolable annulera la garantie du produit.

---

 **Mounting Warning:** Mount the processor with the front or back of the unit facing down. For safety, do NOT mount the processor with the filter side down. Mounting with the fan side down is acceptable only if approved metal screen filters have been installed in all fan exhausts.

---

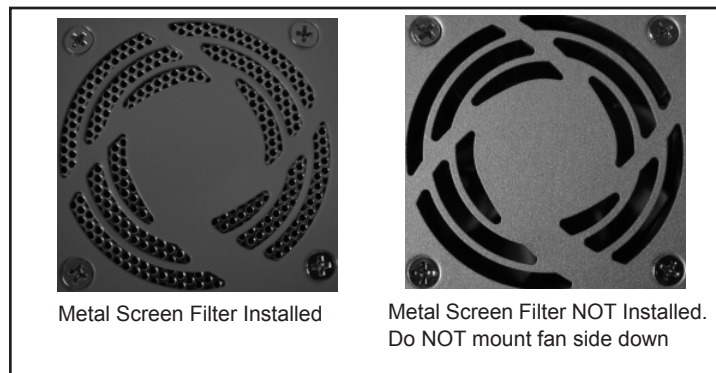

- Make sure heavy equipment is loaded evenly in the rack to avoid a hazardous condition. The rack should safely support the combined weight of all the equipment it supports.
- Before the system is connected to the supply circuit, be sure to check equipment nameplate ratings to avoid overloading circuits. Overloading may damage over-current protection devices and supply wiring.
- Be sure to maintain reliable grounding for rack-mounting equipment. Pay particular attention to supply connections.
- Slots and openings in the cabinet are provided for ventilation. To ensure sufficient air circulation for reliable system operation, and to prevent overheating, maintain a minimum of 1.5 inches (38.1 mm) of clearance on the top and sides of the cabinet and between M-Series Processors.

---

This equipment is to be powered by a Listed power supply for the U.S. and Canada, or a power supply that meets the requirements for use where either IEC60950 or EN60950 is applicable.

---

- To ensure safe operation, the system power must be properly grounded. If the unit is mounted within a rack, verify that it is reliably connected to electrical ground. The ground terminal on the power input must be connected to the grounded chassis/enclosure of the power supply. This insures electromagnetic compliance and proper operation.
- The ITE is to be connected only to PoE networks that do not route outside the plant.

## Flat Surface Mounting

The M-Series Processor may be mounted on any stable surface using the provided case mounting brackets. (Use the appropriate bracket for the Processor model.) Allow at least 1.5 inches (38.1 mm) of clearance at the sides and top of the unit.

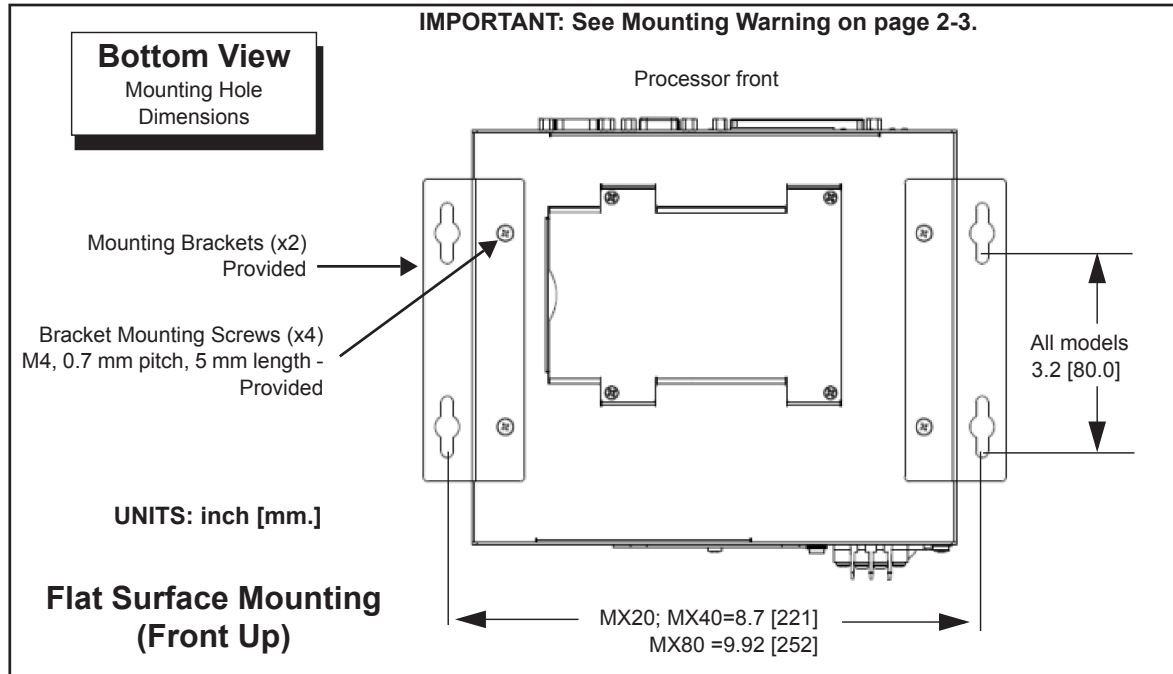

### Mounting Bracket Installation

NOTE: If the Processor uses a Compact Flash card, mount with the Processor front facing upward so the CF card does not fall out due to vibration.

#### To mount the Processor using the mounting brackets:

1. Fasten the two mounting brackets to the bottom of the Processor using the bracket mounting screws.
2. Using the mounting brackets as a template, mark the surface mounting holes in the desired location. The surface must be sufficiently sturdy to hold the unit, stable, and free of vibration.
3. Drill four surface mounting holes in the mounting surface.
4. Insert four mounting screws in the mounting holes and tighten them until approximately 0.2 inches (5 mm) is left exposed. The mounting screws must be at least size #12 (min. 0.216 inches or 5.486 mm) and long enough to provide sufficient support.
5. Maneuver the Processor so mounting bracket slots align with the mounting screws.
6. Place the slots over the screws and slide the Processor down until the screws fit snugly into the mounting bracket slots.

## DIN Rail Mounting

The M-Series Processor may be bottom-mounted on a DIN rail using the optional DIN Rail Mount kit (MX20/MX40: Part # 606-0683; MX80: Part # 95A906038).

## DIN Rail Mount Kit Installation

**NOTE:** If the Processor uses a Compact Flash card, mount with the Processor front facing upward so the CF card does not fall out due to vibration.

### To mount the Processor using the DIN Rail Mount kit (see diagram):

1. To fasten the mounting bracket to the bracket holding plate, insert the bracket mounting screws from the reverse side of the bracket holding plate.  
Be sure to use the appropriate holes in the holding plate for the desired bracket orientation. The part of the bracket that contains the butterfly clip should be on the bottom.
2. Fasten the bracket holding plate onto the bottom of the processor using the plate mounting screws.
3. Hook the bottom of the mounting bracket in the bottom flange of the DIN rail. The butterfly clips will offer some resistance.
4. While exerting slight upward force, clip the top of the mounting bracket over the top flange of the DIN rail.
5. Verify that the bracket is clipped securely to the rail.

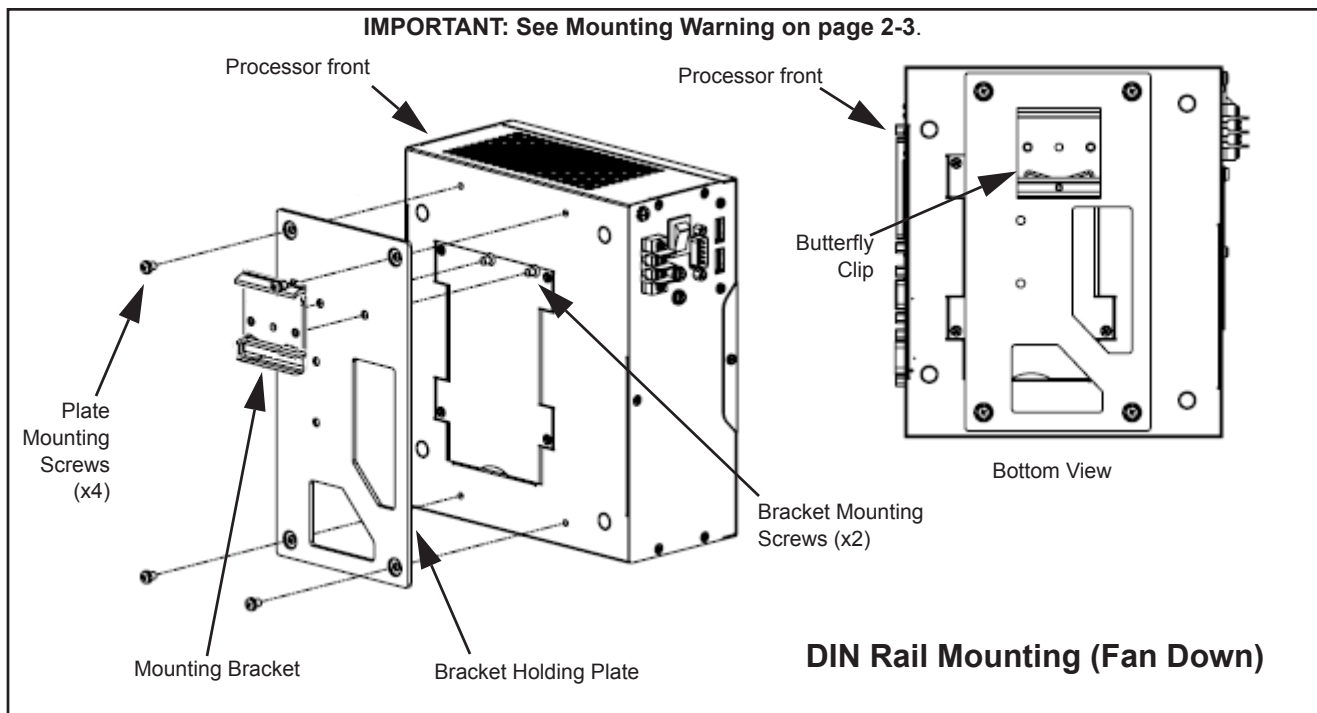

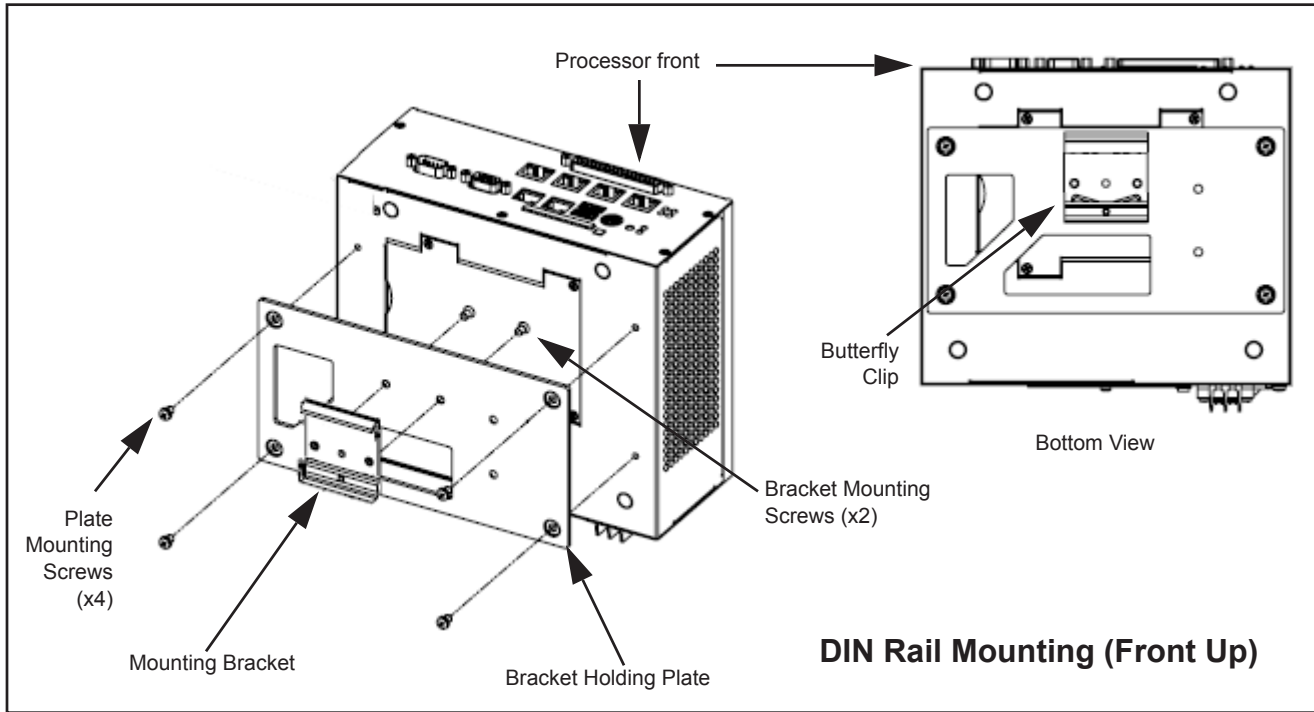

# MX20 and MX40 Status Lights

This illustration shows the status lights on the front of the MX20 and MX40 Processors.

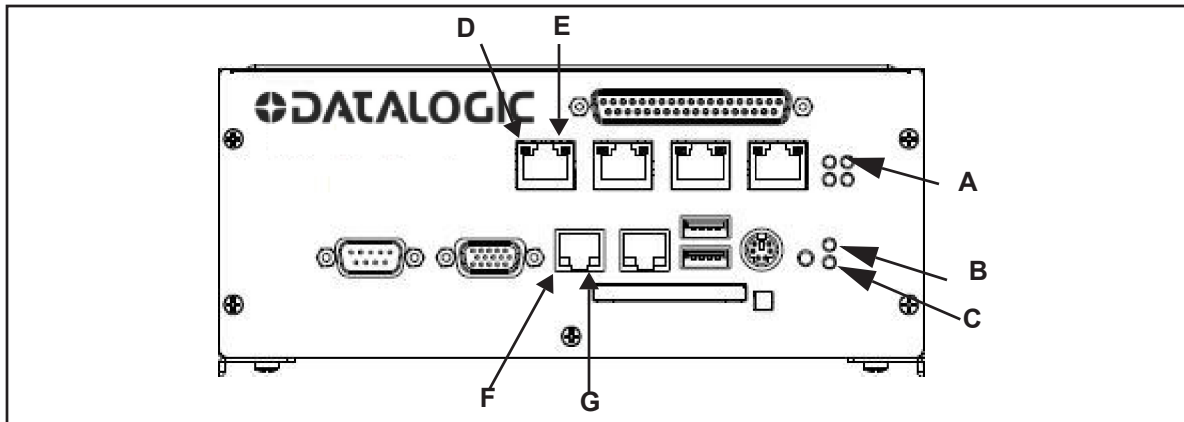

Symbol	Name	When lit indicates:
A	PoE: MX40 = 4 MX20 = 2	Power over Ethernet (PoE) is active (M1xx camera only)
B	Power	Power is On
C	HDD	Blinking: Solid-state hard drive is active
D	PoE Activity/Link: MX40 = 4; MX20 = 2	On: Link is established Blinking: Data is being transferred
E	PoE Speed: MX40 = 4; MX20 = 2	Off: 10 Mbps Green: 100 Mbps Orange: 1000 Mbps (Gigabit)
F	LAN 1 and 2 Speed	Off: 10 Mbps Green: 100 Mbps Orange: 1000 Mbps (Gigabit)
G	LAN 1 and 2 Activity/Link	On: Link is established Blinking: Data is being transferred

## MX80 Status Lights

This illustration shows the status lights on the front of the MX80 Processor.

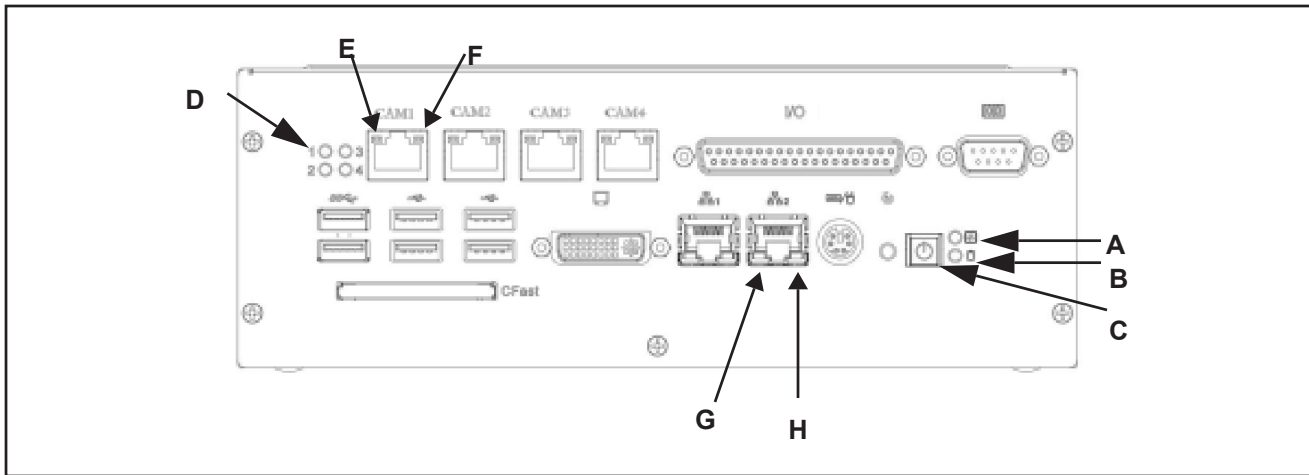

Symbol	Name	When lit indicates:
A	Diagnostic	Continuously: No physical storage connected Blinking: No memory installed
B	HDD	Blinking: Solid-state hard drive is active
C	Power	Power is On
D	PoE (4)	Power over Ethernet (PoE) is active (M1xx camera only)
E	PoE Activity/Link (4)	On: Link is established Blinking: Data is being transferred
F	PoE Speed (4)	Off: 10 Mbps Green: 100 Mbps Orange: 1000 Mbps (Gigabit)
G	LAN 1 and 2 Speed	Off: 10 Mbps Green: 100 Mbps Orange: 1000 Mbps (Gigabit)
H	LAN 1 and 2 Activity/Link	On: Link is established Blinking: Data is being transferred

## MX20 and MX40 Processor Power Supply Connection



**Warning:** To avoid electrical shock, disconnect all power to the power supply before working on it.



**Avertissement:** Pour éviter le choc électrique, débranchez toute la puissance à l'alimentation d'énergie avant de travailler à lui.

The MX20 and MX40 power inputs use standard spade terminals to connect the power supply. The ground terminal on the power input must be connected to the power supply's grounded chassis/enclosure. This connection is needed to insure electromagnetic compliance and proper operation.

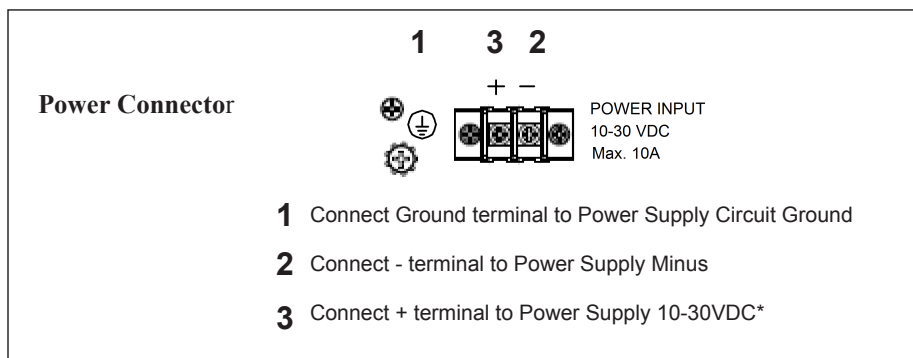

\*Note: The MX20 and MX40 processors require approximately 3.5A @ 24VDC. We recommend using a 24 VDC power supply capable of providing 3.5A current. The M-Series processor runs most efficiently at this voltage which is commonly used in many manufacturing environments.

## MX80 Processor Power Supply Connection



**Warning:** To avoid electrical shock, disconnect all power to the power supply before working on it.



**Avertissement:** Pour éviter le choc électrique, débranchez toute la puissance à l'alimentation d'énergie avant de travailler à lui.

The MX80 power input uses the supplied connector. Wire the power supply cable to the connector, then plug it into the power connector on the rear of the processor. The ground terminal on the power input must be connected to the power supply's grounded chassis/enclosure. This connection is needed to insure electromagnetic compliance and proper operation.

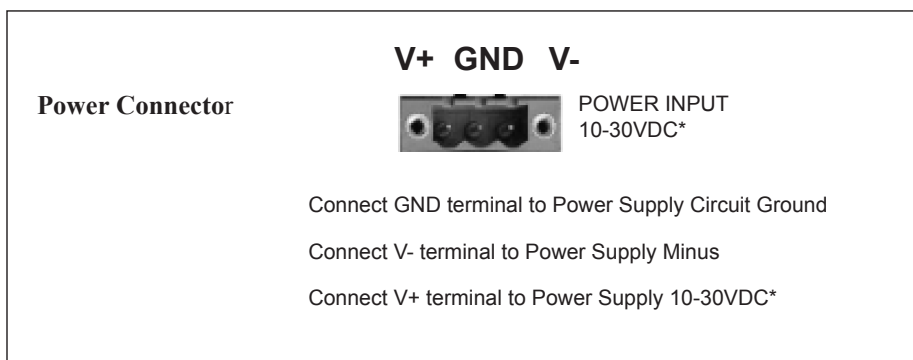

\*Note: The MX80 processor requires approximately 5A @ 24VDC. We recommend using a 24 VDC power supply capable of providing 5A current. This voltage is commonly used in many manufacturing environments.



# M-Series Cameras

---

## Introduction

This section describes digital cameras provided by Datalogic Automation, Inc. and other third-party manufacturers. Our cameras can be used only with our M-Series Processors. The M-Series processors and Impact software will also support the third-party cameras listed later in this chapter.

Datalogic Automation, Inc. does not support the use of these cameras in any manner other than described herein.

M-Series cameras acquire an image when a signal is present on the trigger input of the camera trigger/power cable, then digitize images at the camera source and transmit them directly to the processor over the Ethernet cable. These cameras provide 8-bit resolution using internal 12-bit A/D converters and some have progressive scan shutter exposure (allowing individual pixel readings). Third-party cameras may have different specifications. All cameras are capable of Gigabit transmission rates.

M-Series cameras have a hard-coat finish case that helps eliminate ground loops. All camera settings (shutter, strobe, partial scan, etc.) are configured using Impact software and are maintained in the M-Series processors' memory so there are no physical switches on the cameras.

All camera settings must be configured using the Settings tab in the Vision Program Manager (VPM) or Settings program. For more detailed information, refer to the Impact Reference Guide (843-0093).

---

## Safety Precautions

Read all of the following instructions before setting up your camera. Save this document for later use.

- Follow all warnings and instructions in this manual and in other user guides shipped with your hardware components.
- Do not attempt to disassemble the camera. Do not remove screws or attachments. There are no user-serviceable parts inside. Refer servicing to Datalogic Automation, Inc.
- All M-Series and third-party cameras connect to the M-Series Processors using a Cat5E Ethernet cable (606-0457-x). Cat6 cable is required for distances greater than 25 meters. Using any other cable may cause intermittent data transmission. Cameras connect to power and triggering signals using a cable and terminal block. See "Connecting the Camera" on page 3-8 for more details.

---

**NOTE:** We recommend that you do not use a switch or a router between the M-Series Processor and the camera.

---

- This camera is designed for indoor use. Do not expose it to moisture, including rain or snow, and avoid operating it in wet areas. Should the camera become wet, turn off the power immediately. Moisture can damage the camera and create danger of electric shock. Avoid using the camera when the humidity is above 90%.

- Make sure your camera has enough airflow around it for proper ventilation. The safe case temperature during operation is from 0° to 50° C (32° to 122° F).
- Mount the camera body in a fixed position where it will not be subject to excessive vibration.
- To reduce stress on the camera connectors and cable, loop the cable and fasten it to the camera's mounting block. Do not crimp or tie the cable tightly with wire ties as this may damage it internally. The cable's minimum bend radius is fifteen times the cable diameter. It is not intended for continuous flexing or movement. Be sure that cables are safely routed away from vehicle and pedestrian traffic.
- Check the intended installation area to be sure there is enough room for the camera and any lighting that may be needed.
- Avoid areas with excessive heat, vibration, and environmental contaminants.
- Mount cameras away from devices that emit large amounts of electromagnetic energy.

---

## Before you install the camera

**Temperature Precaution:** If your camera arrives in very hot or cold weather, allow it to reach room temperature before using it. Wait for any condensation to dry completely before connecting it to the M-Series Processor or power.

Carefully remove the camera and cabling from the shipping package and inspect each item. Save all packing materials so you can repack the camera in case you need to move or ship it.

---

**NOTE:** Do not leave the camera imager uncovered. When you remove the lens cap, you must replace it with a lens. Do NOT attempt to clean the camera imager or imager cover. Do NOT spray the imager or imager cover with compressed gas as this may leave spots.

---

# Camera Dimensions

This section provides dimensions for our cameras. For information about third-party cameras, consult the manufacturer's documentation for those cameras.

## M1xx Camera Dimensions

The M1xx series of cameras weighs approximately 4 ounces (112 grams) with a mounting block, but without a lens.

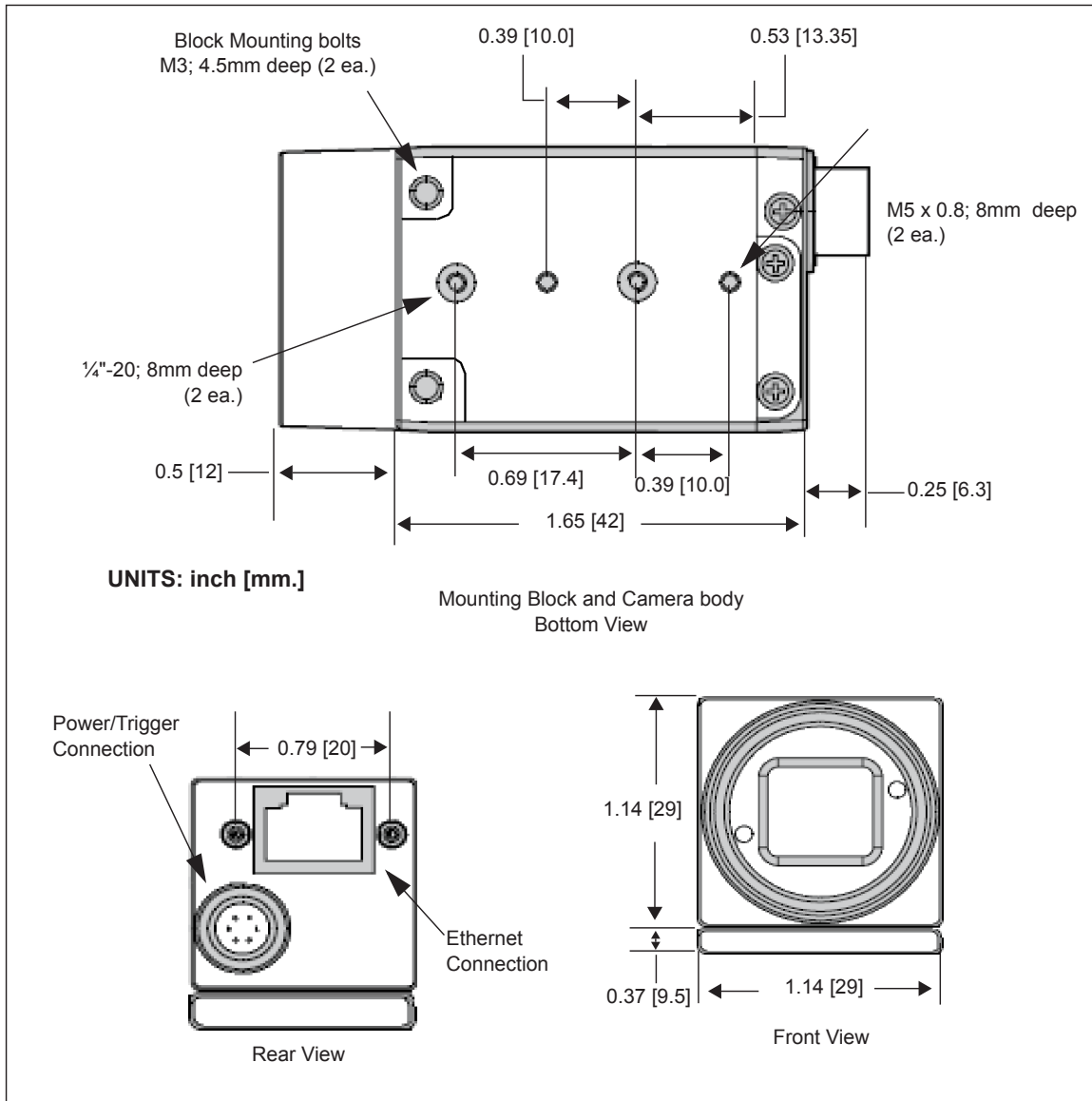

# M2xx Camera Dimensions

The M2xx series of cameras weighs approximately 6.2 ounces (177 grams) with a mounting block, but without a lens.

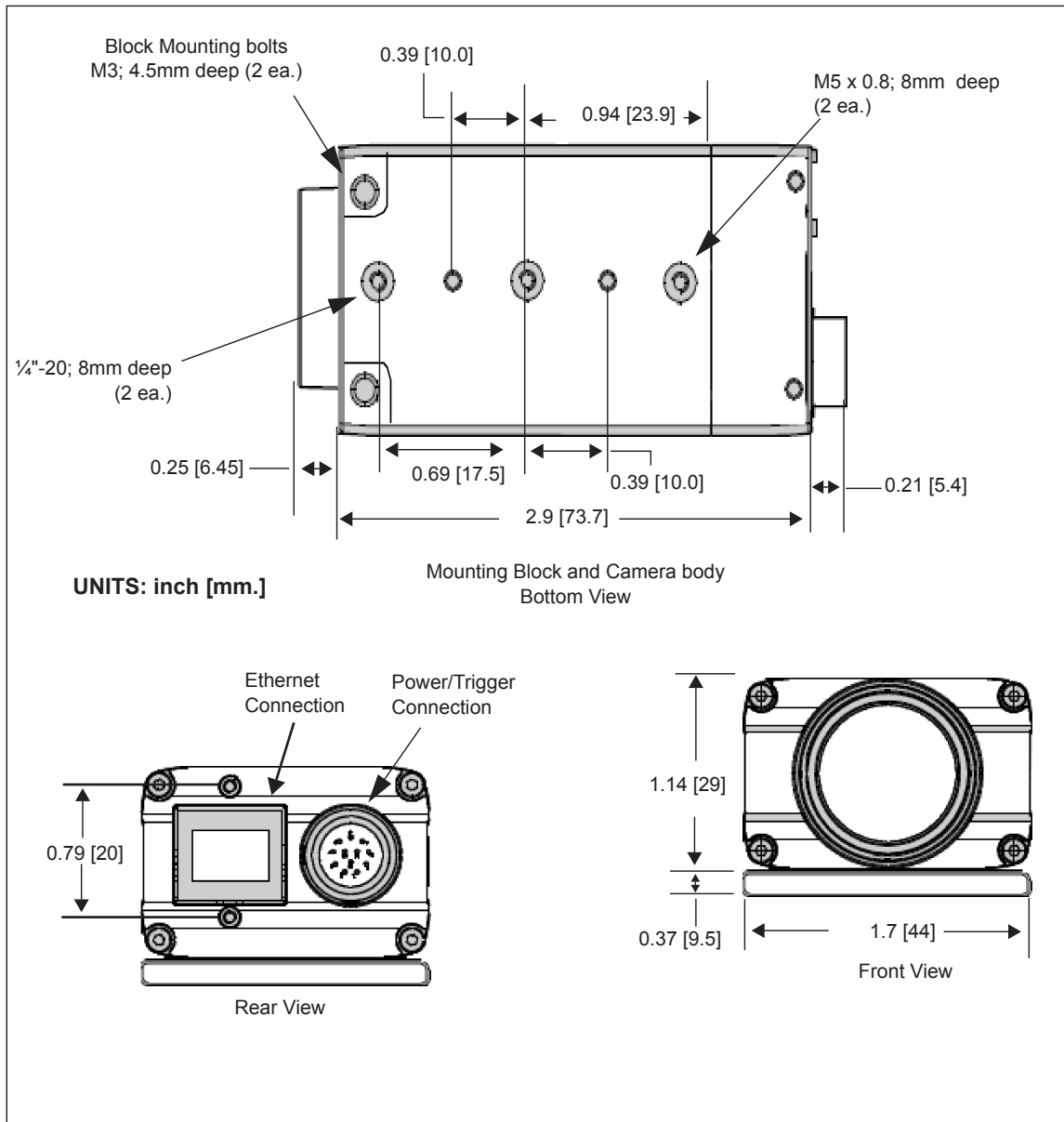

# M3xx Camera Dimensions

The M3xx series of cameras weighs approximately 8.5 ounces (242 grams) with a mounting block, but without a lens.

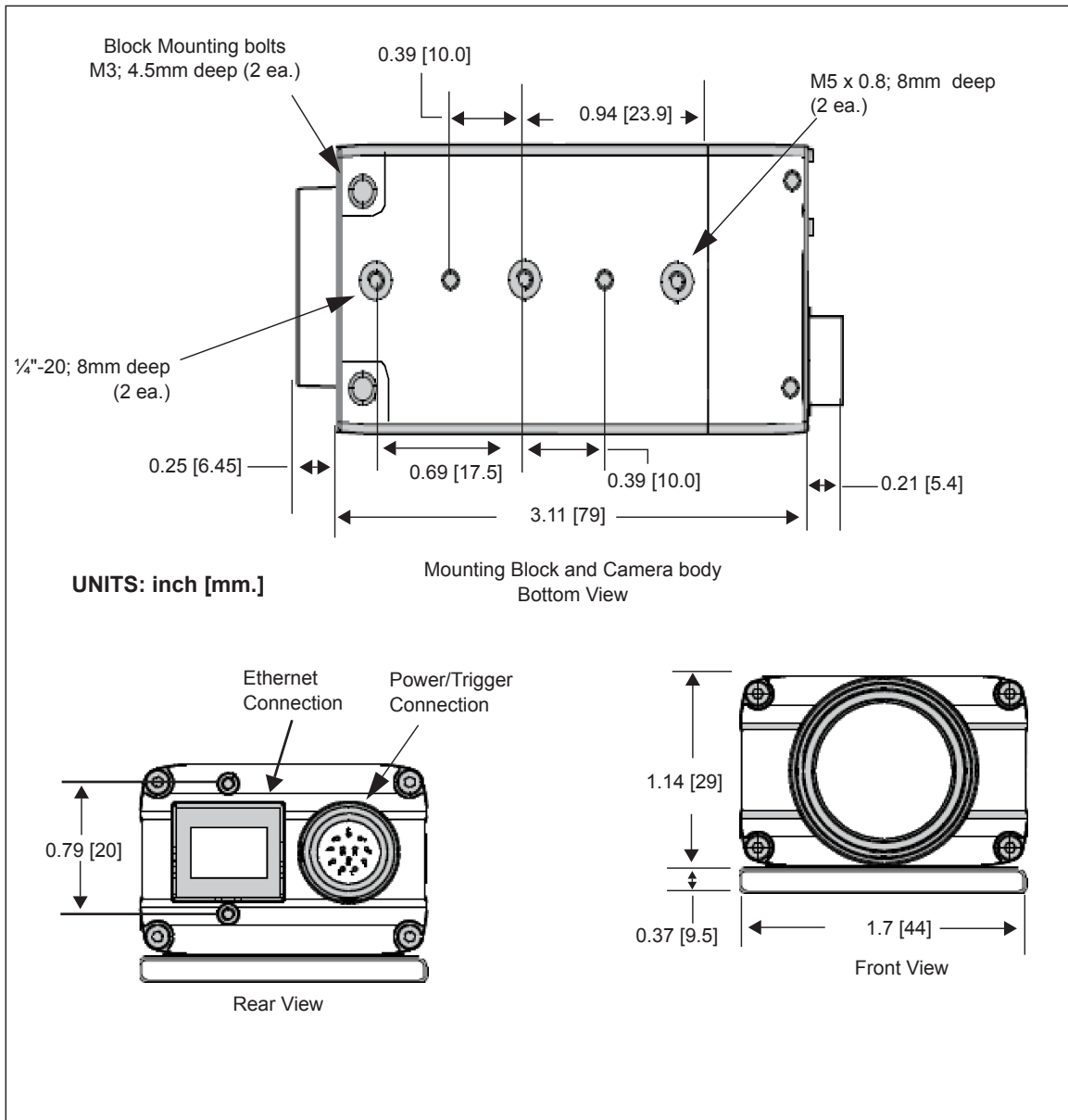

# M5xx Camera Dimensions

The M5xx series of cameras weighs approximately 8 ounces (235 grams) without a lens. With a lens adapter the weight is approximately 12.8 ounces (367 grams).

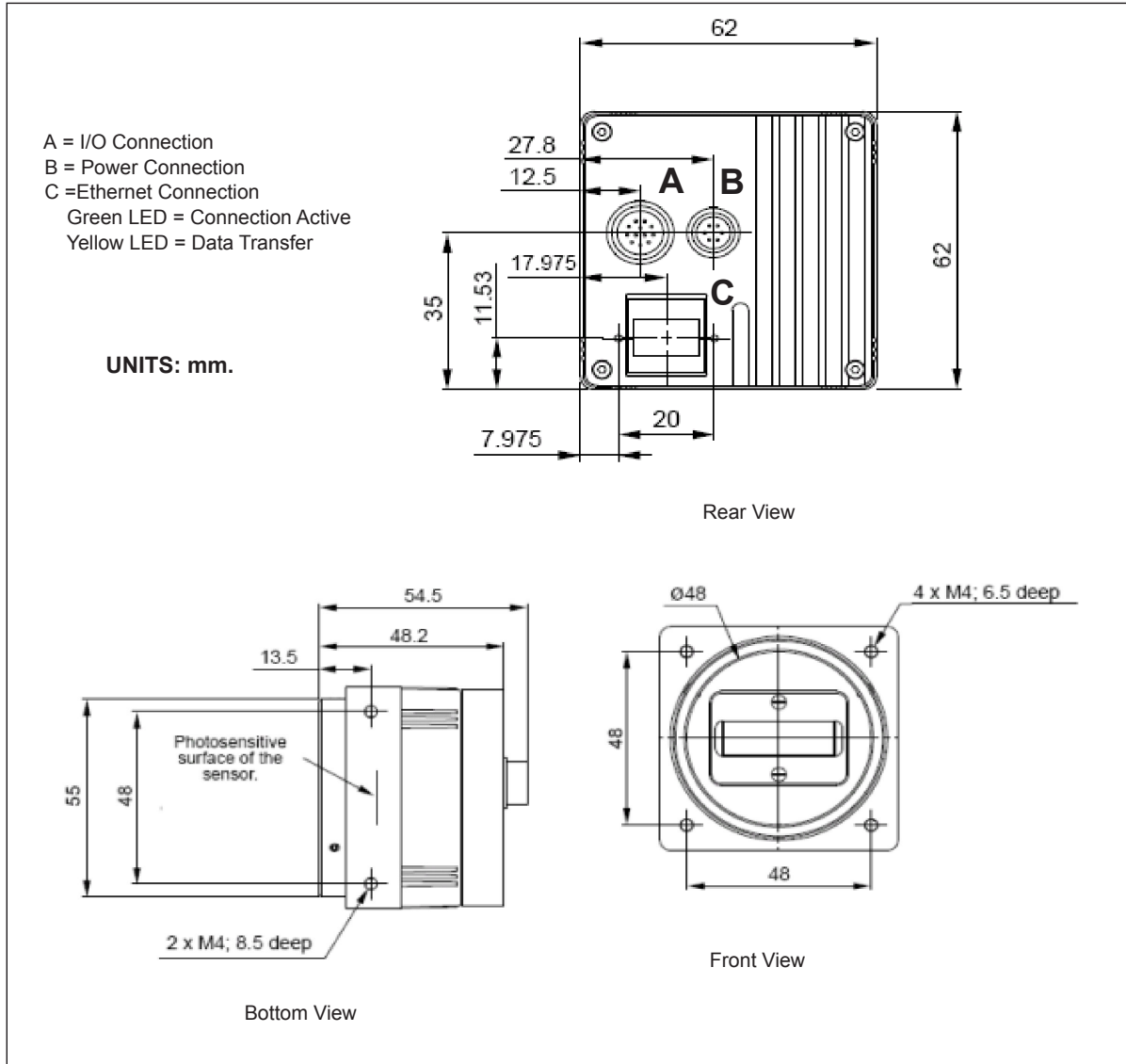

## Mounting the Camera

This section provides instructions for mounting our cameras. For information about third-party cameras, consult the manufacturer's documentation for those cameras.

### To mount an M-Series camera (except M5xx)

1. With the mounting block held tightly against the camera body, insert two mounting bolts through the mounting bolt holes (see diagram).

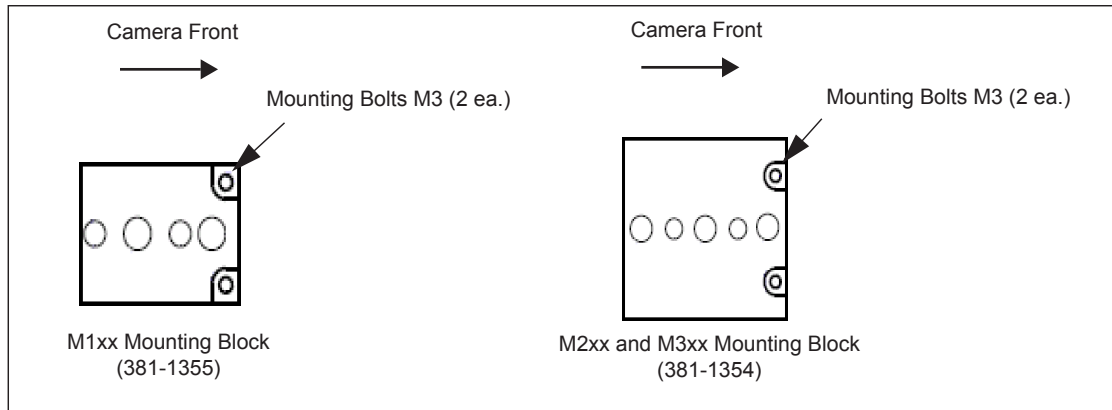

2. Turn the mounting bolt clockwise to tighten the block and secure it to the camera.
3. Use appropriately sized fasteners in the pre-threaded holes in the bottom of the mounting bracket to secure the mounting block to a rigid surface for proper stability and heat transfer. (See “Camera Dimensions” on page 3-3.)

### To mount an M5xx camera

1. With the camera body held tightly against the desired mounting surface, insert two mounting bolts through the mounting surface and into the mounting bolt holes (see diagram).

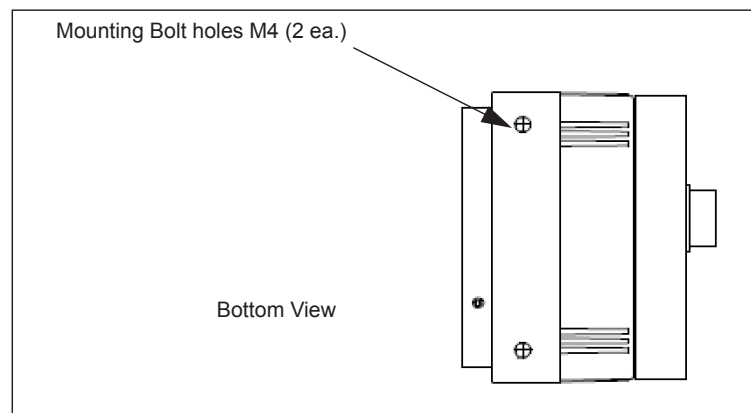

## Connecting the Camera

**WARNING:** Never wire M1xx Camera Strobe Outputs in parallel with M1xx, M2xx, or M3xx Camera Strobe Outputs. This will damage the cameras.

### M1xx Camera Connection

To connect M1xx camera power, trigger signals, and strobe outputs, use cable 606-0674-xx (6 pin Hirose Male to DB9) with terminal block 661-0399.

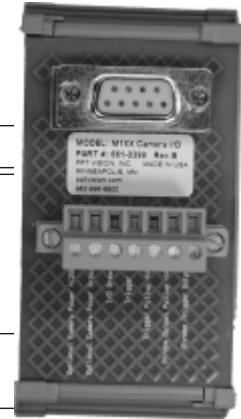

Terminal Name	Signal	Notes
Optional Camera Power +12VDC	Camera Power	Do NOT apply power to this terminal if using Power Over Ethernet (PoE) +12 VDC (+-10%) @ 250 mA Max Maximum: +13.2 VDC Minimum: +11.3 VDC
Optional Camera Power Ground	Camera Power Ground	Required when NOT using Power Over Ethernet (PoE)
I/O Ground	I/O Ground	
Trigger In**	Camera Trigger In	0 to +24 VDC recommended Maximum +30 VDC As sinking input Off: 0 to +1.4 VDC On: +2.2 to +24 VDC; 5 to 15 ma As sourcing input (see Trigger Pullup +VCC) Off: +2.2 to +24 VDC; 5 to 15 ma On: 0 to +1.4 VDC
Trigger Pullup +VCC**	Trigger In Pullup - use if Trigger In needs sourcing (see Note 1 below)	+24 VDC recommended Maximum +30 VDC (**Block contains 1.6k Ohm 1W resistor between Trigger In and Trigger Pullup +VCC)
Strobe Output Pullup +VCC*	Strobe Supply Voltage - use if Strobe Trigger Output needs sourcing (see Note 2 below)	Based on Strobe requirement (optional) Max: +30 VDC; 50 ma (*Block contains 1.6k Ohm 1W resistor between Strobe Trigger Output and Strobe Output Pullup +VCC)
Strobe Trigger Output*	Trigger Out to Strobe (see Note 3 below)	DO NOT APPLY ANY VOLTAGE DIRECTLY TO THIS OUTPUT. DO NOT WIRE OUTPUTS IN PARALLEL.

**NOTE 1:** If Camera Trigger In requires a sinking signal, set the Software Trigger Event to Rising Edge. If it requires a sourcing signal, set the Software Trigger Event to Falling Edge.

**NOTE 2:** If Strobe Trigger Output requires a sinking signal, set the Strobe Trigger Output to Falling Edge. If it requires a sourcing signal, set the Strobe Trigger Output to Rising Edge.

**NOTE 3:** Disconnecting the camera will turn on some strobe lights.



# M1xx Circuit Diagrams

## M1xx Trigger In Circuit

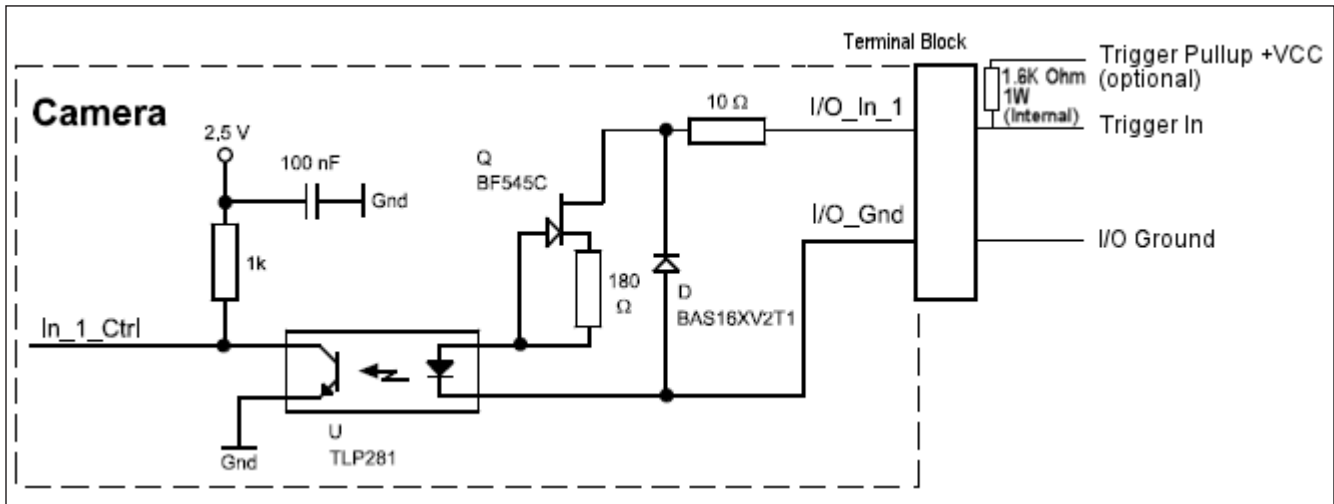

**WARNING:** Never wire M1xx Camera Strobe Outputs in parallel with M1xx, M2xx, or M3xx Camera Strobe Outputs. This will damage the cameras.

## M1xx Strobe Trigger Output Circuit

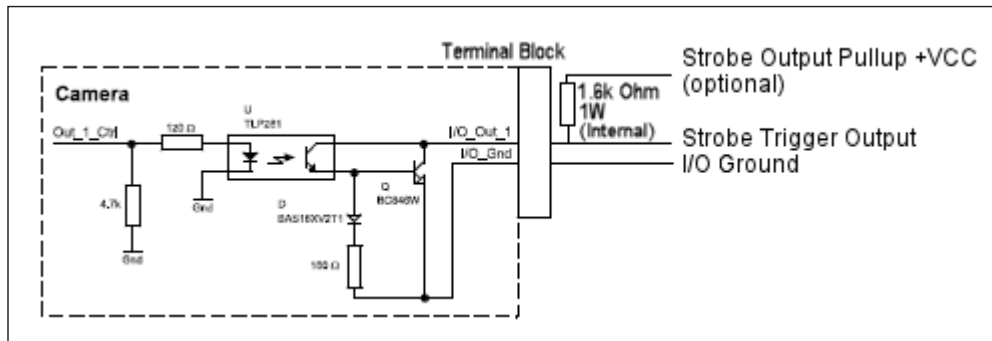

### M1xx Terminal Connections

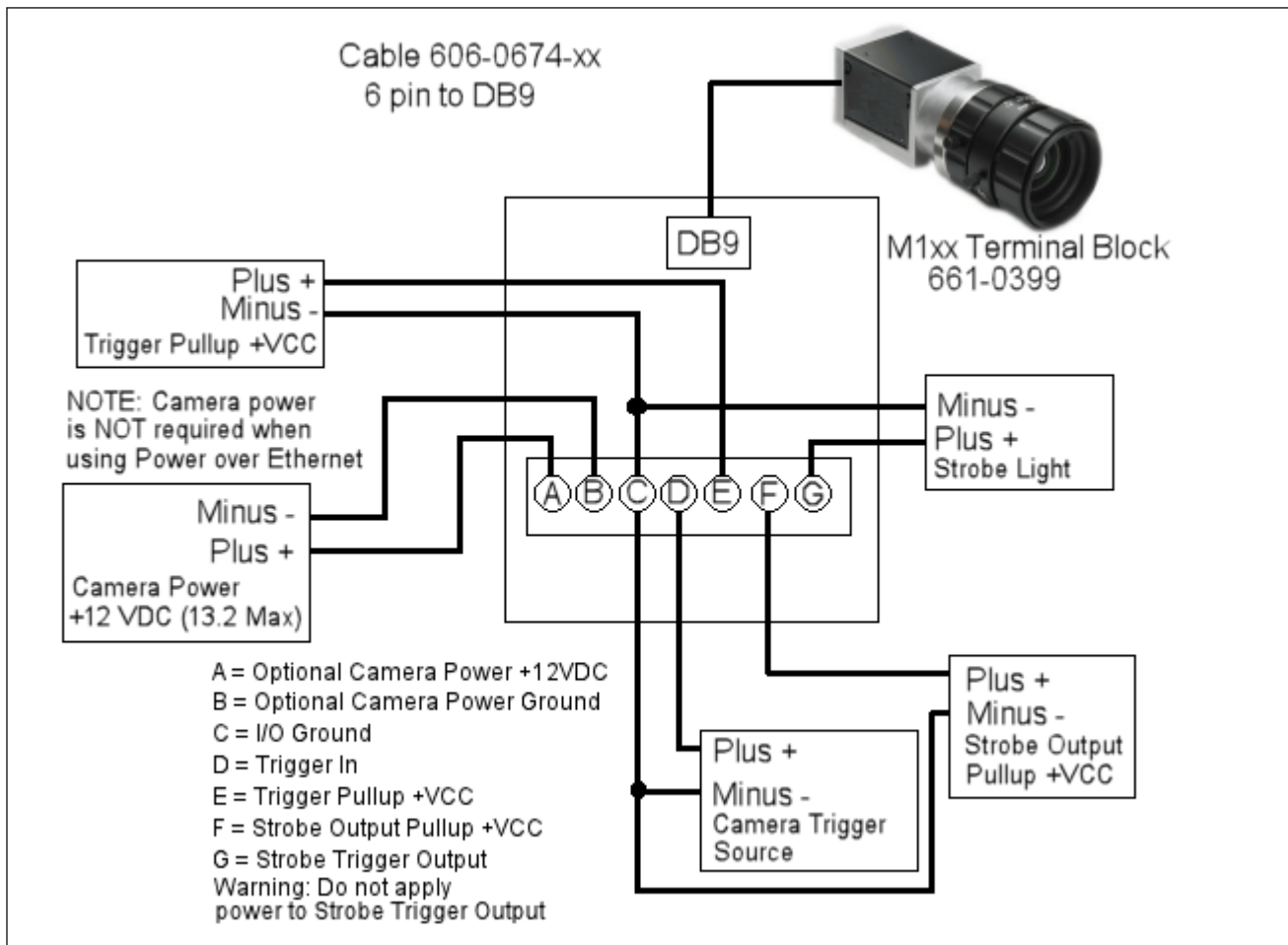

The response times for the strobe output on the M1xx camera will typically fall into the ranges specified below. The exact response time for your application will depend on the external resistor and the applied voltage you use. The shutter begins opening simultaneously with the “Camera Strobe Output” in the diagram. Set the strobe time 60 to 110 microseconds lon-

ger than you would on a M2xx to account for the delays. The shutter time must then be set a little longer than the strobe time.

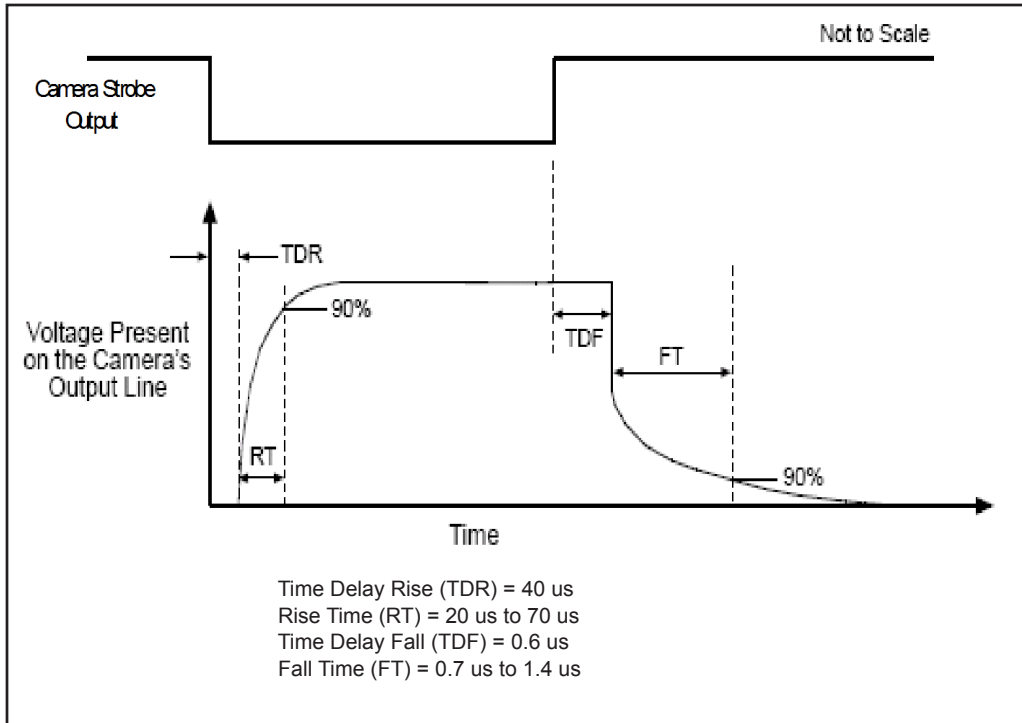

## M2xx and M3xx Camera Connection

To connect M2xx and M3xx camera power, trigger signals, and strobe outputs, use cable 606-0673-xx (12-pin Hirose Male to HD-15) with terminal block 661-0400.

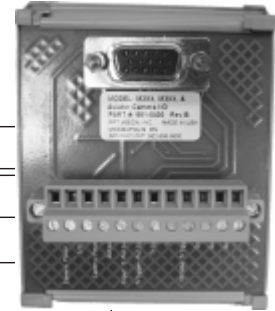

Terminal	Signal Name	Notes
Camera Power Ground	Camera Ground	
I/O Ground	I/O Ground	
Camera Power +VDC	Camera Power	+12 to +24 VDC recommended @ 500 mA Max Maximum: +30 VDC
Output +VCC	Power for Strobe Trigger Out	+3.3 to +24 VDC; 50 mA Max Maximum: +30 VDC
Input 2 Pullup +VCC	DO NOT USE	Not Currently Supported
Trigger Pullup +VCC	Trigger In Pullup - use if Trigger In needs sourcing input	Recommended: +24 VDC
Trigger In	Camera Trigger In (see Note 1 below)	0 to +24 VDC recommended Maximum +30 VDC As sinking input Off: 0 to +1.4 VDC On: +2.2 to +24 VDC; 5 to 15 ma As sourcing input (see Trigger Pullup +VCC) Off: +2.2 to +24 VDC; 5 to 15 ma On: 0 to +1.4 VDC
Input 2	DO NOT USE	Not Currently Supported
Strobe Trigger Out	Trigger Out to Strobe (see Note 2 below)	DO NOT APPLY GROUND DIRECTLY TO THIS OUTPUT.
Output 2	DO NOT USE	Not Currently Supported
Output 3	DO NOT USE	Not Currently Supported
Output 4	DO NOT USE	Not Currently Supported

NOTE 1: If Camera Trigger In requires a sinking signal, set the Software Trigger Event to Rising Edge. If it requires a sourcing signal, set the Software Trigger Event to Falling Edge.

NOTE 2: If Strobe Trigger Output requires a sinking signal, set the Strobe Trigger Output to Falling Edge. If it requires a sourcing signal, set the Strobe Trigger Output to Rising Edge.

# M2xx and M3xx Circuit Diagrams

## M2xx and M3xx Trigger In Circuit

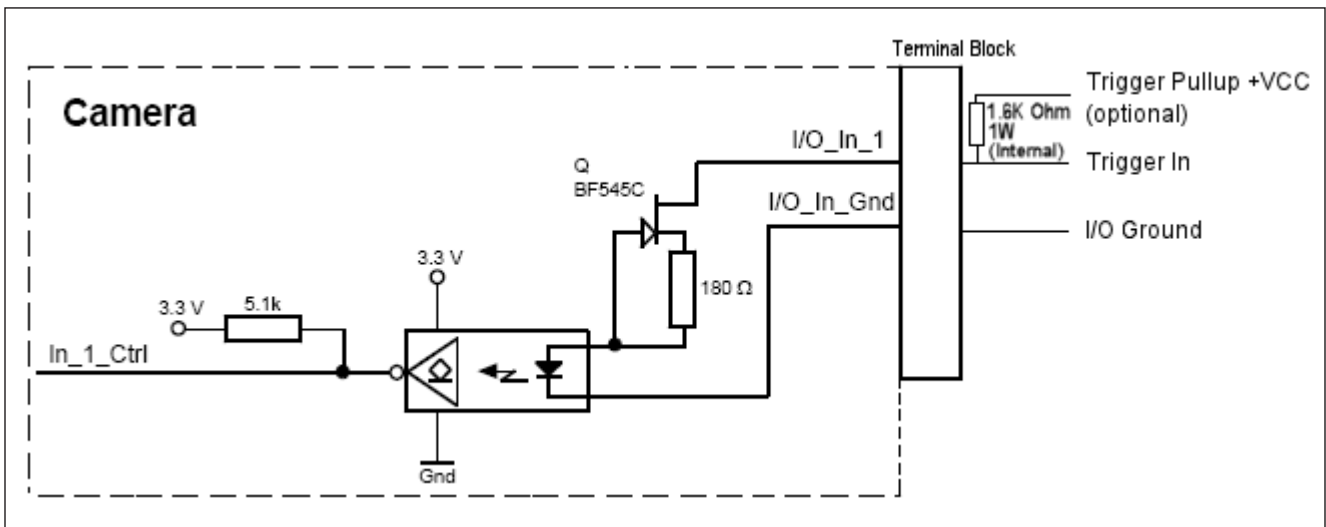

## M2xx and M3xx Strobe Trigger Out Circuit

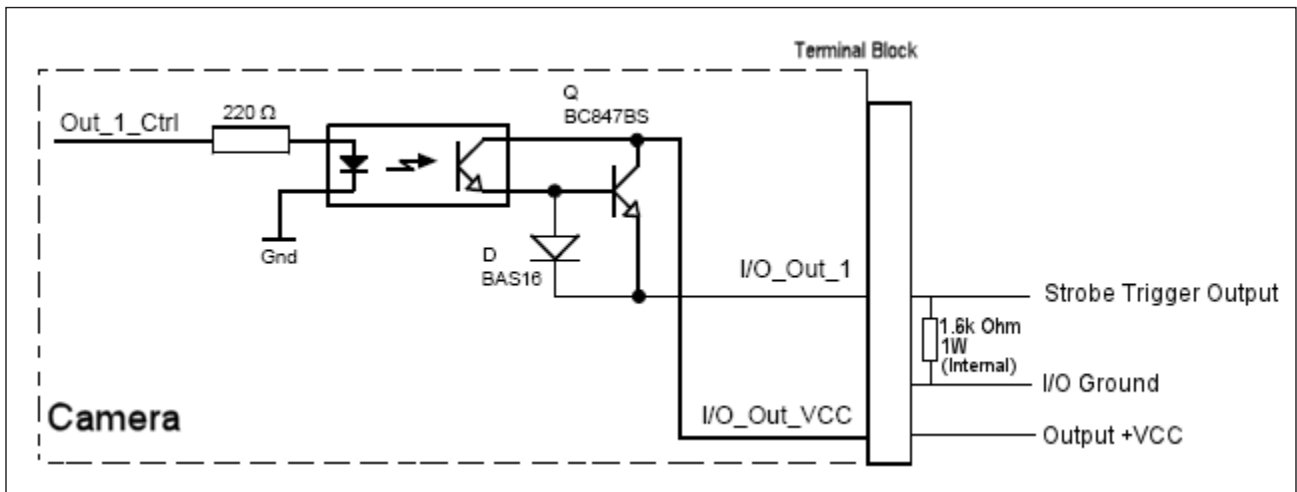

**M2xx and M3xx Terminal Connections**

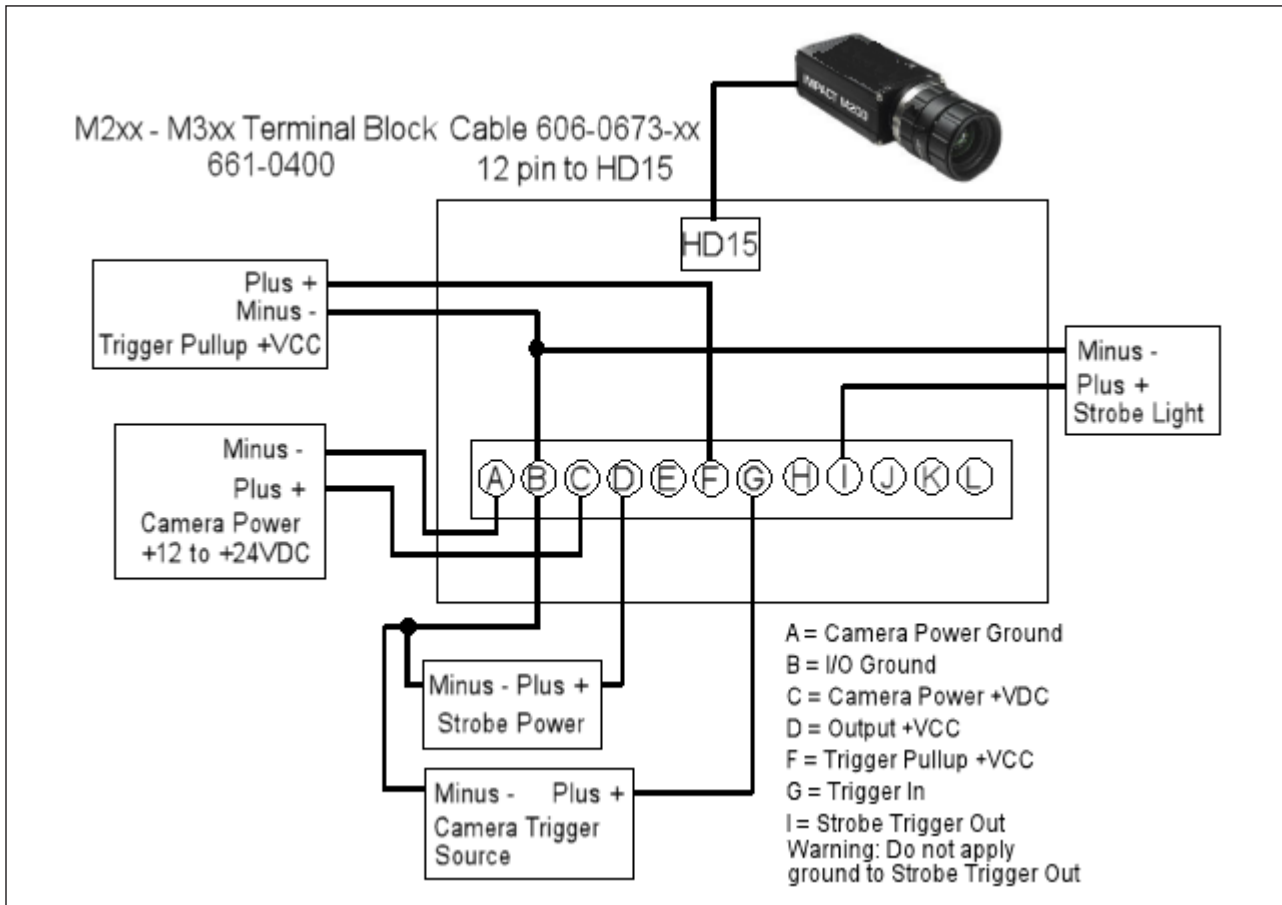

The response times for the strobe output on the M2xx and M3xx cameras will typically fall into the ranges specified below. The exact response time for your application will depend on the external resistor and the applied voltage you use.

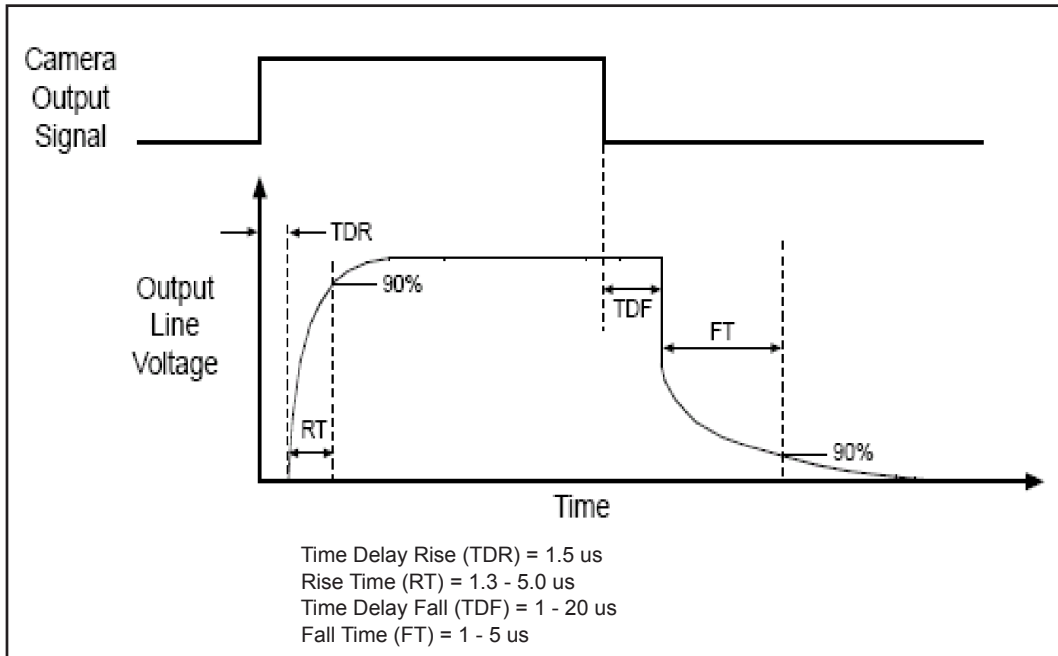

## M5xx Camera Connection

To connect the M5xx, use terminal block 661-0401 with cable 606-0673-xx (12-pin to HD-15 camera I/O) and cable 606-0674-xx (6 pin to DB9 camera power). For details about programming the Line Trigger, refer to the Impact Reference Guide (843-0093)



NOTE: Do NOT use the M2xx/M3xx terminal block (661-0400) or M1xx block (661-0399) to connect this camera. They will NOT provide the correct signal levels.

Terminal	Signal Name	Notes
Camera Power Ground	Camera Ground	See Note 1 Below
I/O Ground	I/O Ground	See Note 1 Below
Camera Power +12VDC	Camera Power	+12 VDC (+-10%) @ 700 mA Max
Input 1 -	No Connection	DO NOT USE
Input 1 +	Frame Start Trigger	As sinking input Off 0 to +0.8 VDC On: +2.0 to +5 VDC As sourcing input (see Input 1 Pullup) Off: +2.0 to +5 VDC On 0 to +0.8 VDC Maximum: +5 VDC
Input 2 -	No Connection	DO NOT USE
Input 2 +	Single Line Trigger <b>OR</b> Phase A Line Trigger (Quadrature Encoder)	As sinking input Off 0 to +0.8 VDC On: +2.0 to +5 VDC As sourcing input (see Input 2 Pullup) Off: +2.0 to +5 VDC On 0 to +0.8 VDC Maximum: +5 VDC
Input 3 -	No Connection	DO NOT USE
Input 3 +	Phase B Line Trigger (Quadrature Encoder)	As sinking input Off 0 to +0.8 VDC On: +2.0 to +5 VDC As sourcing input (see Input 3 Pullup) Off: +2.0 to +5 VDC On 0 to +0.8 VDC Maximum: +5 VDC
Output 1 -	Not Currently Supported	DO NOT USE
Output 1 +	Not Currently Supported	DO NOT USE
Output 2 -	Not Currently Supported	DO NOT USE
Output 2 +	Not Currently Supported	DO NOT USE
Input 1 Pullup +5VDC	Frame Start Trigger Pullup - use if Input 1 needs sourcing input	Maximum: +5 VDC
Input 2 Pullup +5VDC	Line Trigger Pullup - use if Input 2 needs sourcing input	Maximum: +5 VDC



Terminal	Signal Name	Notes
Input 3 Pullup +5VDC	Line Trigger Pullup - use if Input 3 needs sourcing input	Maximum: +5 VDC

**NOTE 1:** To help prevent ground loops and possible false triggering, we recommend connecting I/O Ground to Camera Power Ground.

## M5xx Circuit Diagrams

### M5xx Frame Trigger Input Circuit

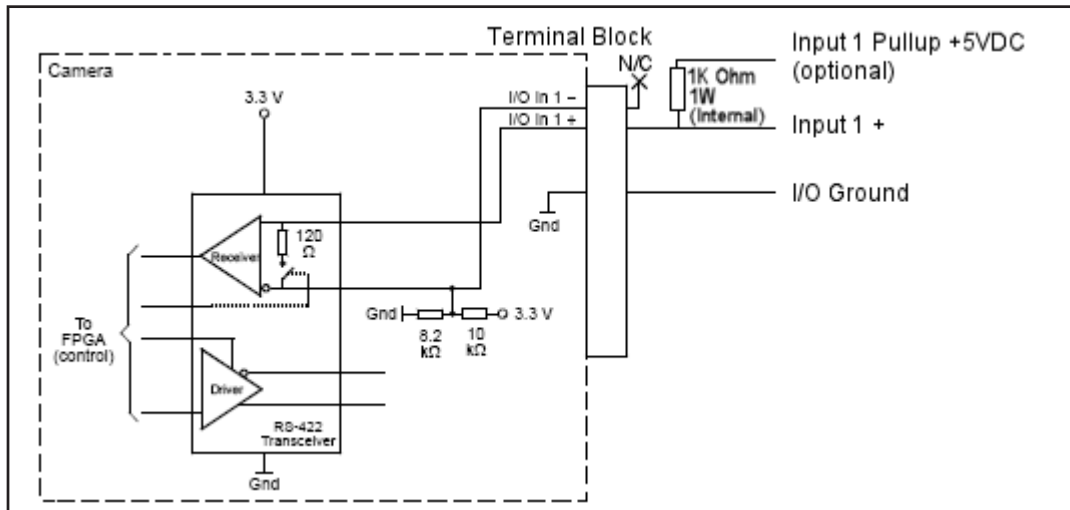

### M5xx Single Line Trigger Input Circuit

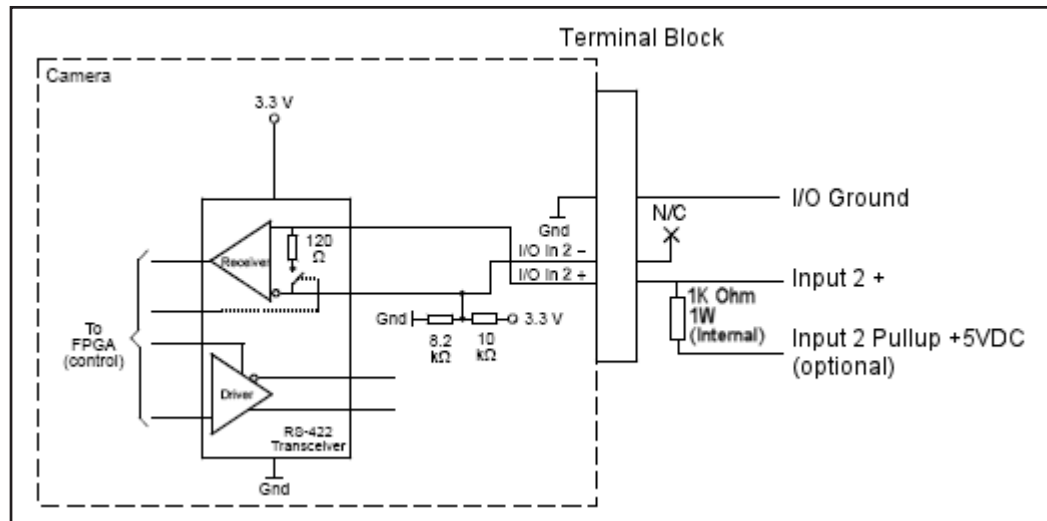

### M5xx Quadrature Encoder Line Trigger Input Circuit

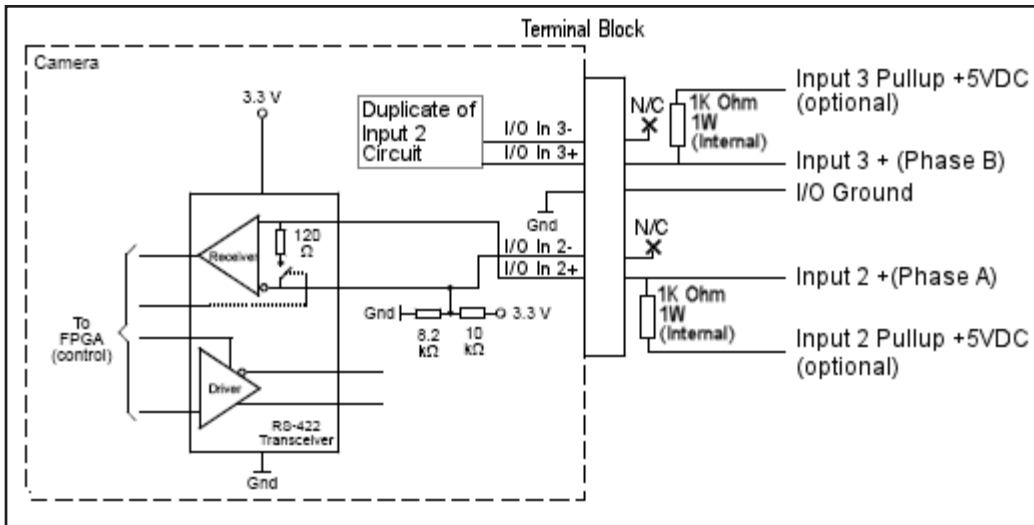

## M5xx Terminal Connections

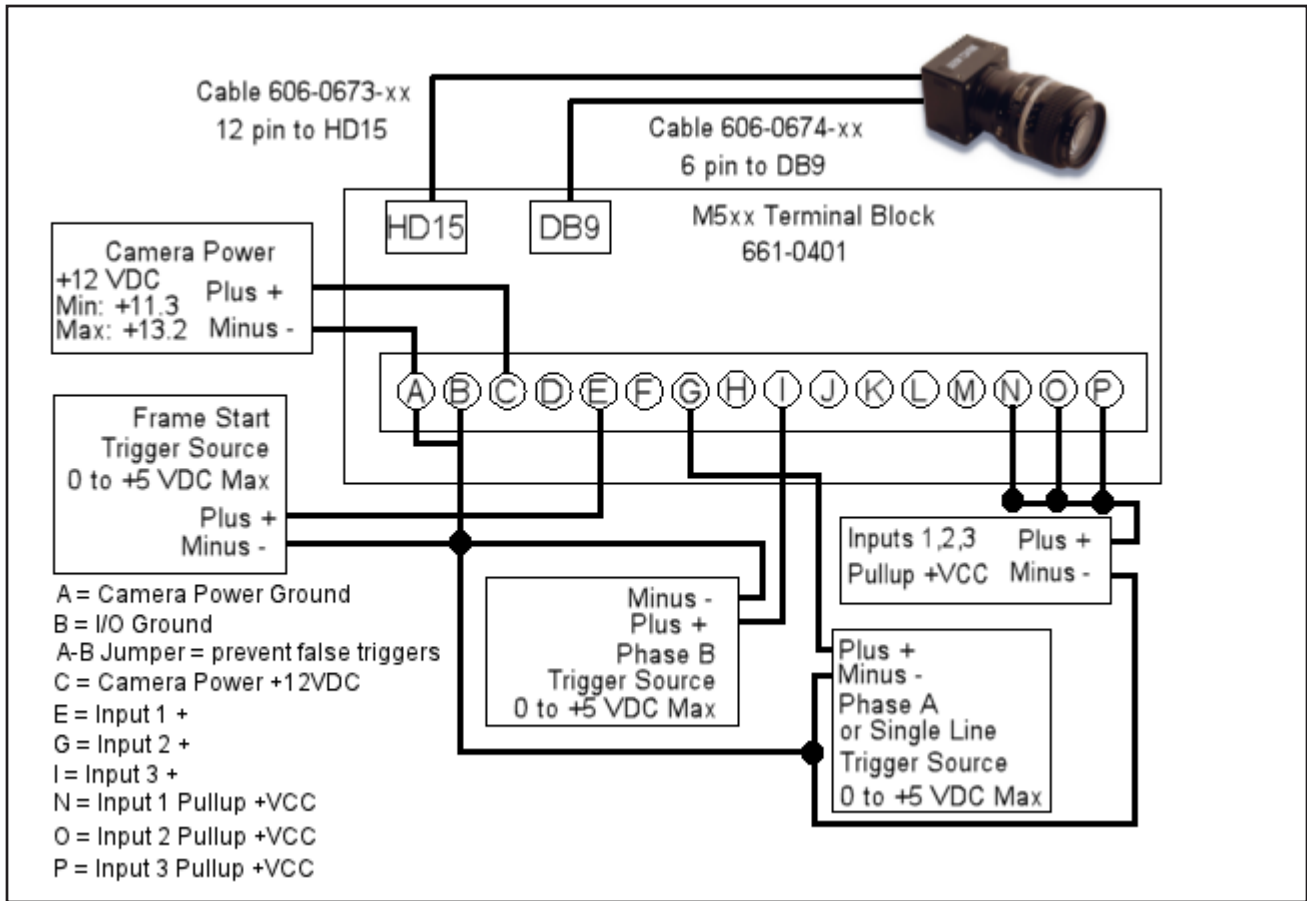

## M5xx Unterminated Cable Connections

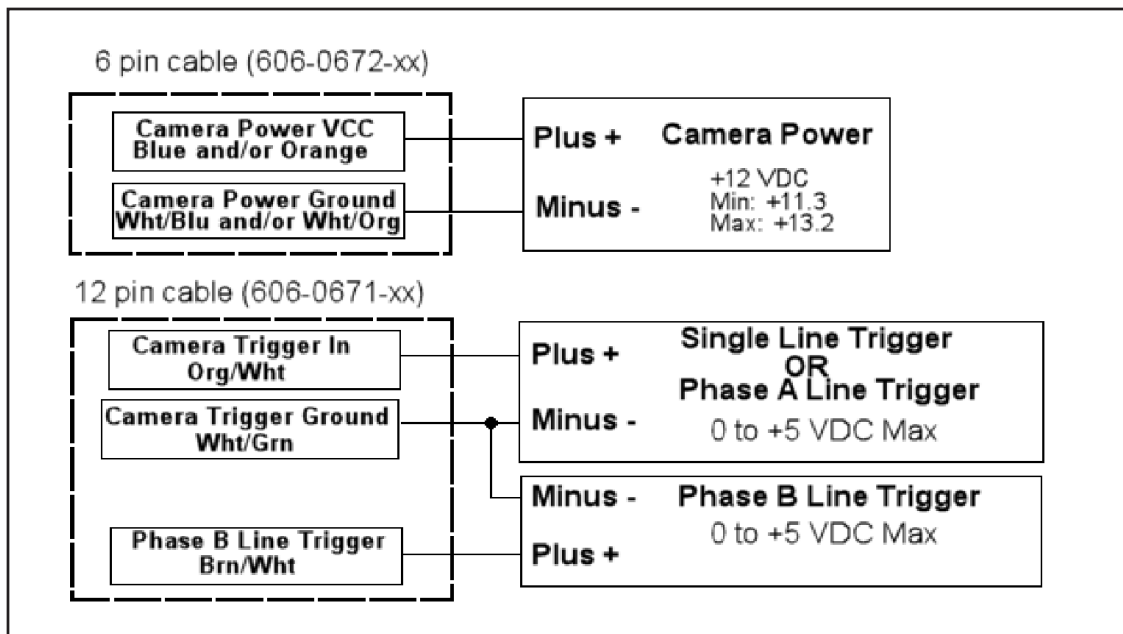

## Third-party Cameras

The M-Series Processor and Impact Software support only the third-party cameras listed in this section. This information, including power and trigger signal connections, are provided by us as a convenience. You must purchase a license from us to connect a third-party camera to the M-Series processor.

**We assume no responsibility for the accuracy or timeliness of this third-party camera information. For complete details and the most accurate specifications for these cameras, consult the manufacturer's documentation.**

## JAI Cameras

**NOTE:** See “JAI Camera I/O Signals” on page 3-27 for important information about camera and strobe signals.

Model (GigE)	Resolution (Megapixels)	Color	Image Horizontal	Image Vertical	Minimum Software Version Required
AT-200GE*	2	Yes	1624	1236	10.3.0
AM-800GE	8	No	3296	2472	10.3.0
CM-140GE*	1.4	Yes (3 CCD)	1392	1040	10.5.0
CM-140GE-UV	1.4	Ultraviolet	1392	1040	10.2.0
CM-030GE-RH (remote head)	0.3	No	659	494	10.2.0

\*See “Color shading support” on page 3-26 for special camera configuration settings.

## JAI Camera Connection

To connect JAI camera power, trigger signals, and strobe outputs, use cable 606-0673-xx (12-pin to HD-15) with terminal block 661-0402.

NOTE: Do NOT use terminal block 248-0141 to connect this camera. It will NOT provide the correct signal levels.

**WARNING: THE POWER AND GROUND CONNECTIONS FOR THIS CAMERA ARE DIFFERENT FROM OUR CAMERAS AND OTHER THIRD-PARTY CAMERAS. USE CAUTION WHEN CONNECTING POWER TO THESE CAMERAS.**

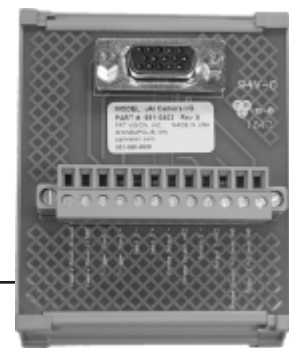

Terminal	Signal Name	Notes
Camera Power Ground	Camera Ground	

Terminal	Signal Name	Notes
Camera Power +12VDC	Camera Power	<b>CM-140GE-UV and CM-030-GE-RH</b> +12 VDC @ 350 mA Max (4.1 W) Maximum: +13.2 VDC <b>AM-800GE</b> +12VDC to +24VDC ±10%, 8.16W (at normal, Full resolution, DC+12V) <b>AT-200GE</b> +10.8VDC to +26.4VDC, 0.67 A (Typical , Full frame, DC +12V in)
Trigger Input -	Camera Trigger -	
Trigger Input +	Camera Trigger +	+0 to +24 VDC Off: 0 to +2.0 VDC On: +4.0 to + 24 VDC Maximum: +24 VDC
Input 2 -	Not Currently Supported	DO NOT USE
Input 2 +	Not Currently Supported	DO NOT USE
Strobe Output -	Strobe Output Ground	
Strobe Output +VCC	Power for Strobe Output	+5 to +24 VDC Maximum: +24 VDC; 100 mA
Output 2 -	Not Currently Supported	DO NOT USE
Output 2 +VCC	Not Currently Supported	DO NOT USE
Strobe Output Pull down GND	Strobe Output Pull down - use if Strobe Output needs sourcing output	
Output 2 Pull down GND	Not Currently Supported	DO NOT USE

## JAI Camera Circuit Diagrams

*JAI Camera Trigger Input Circuit (sourcing)*

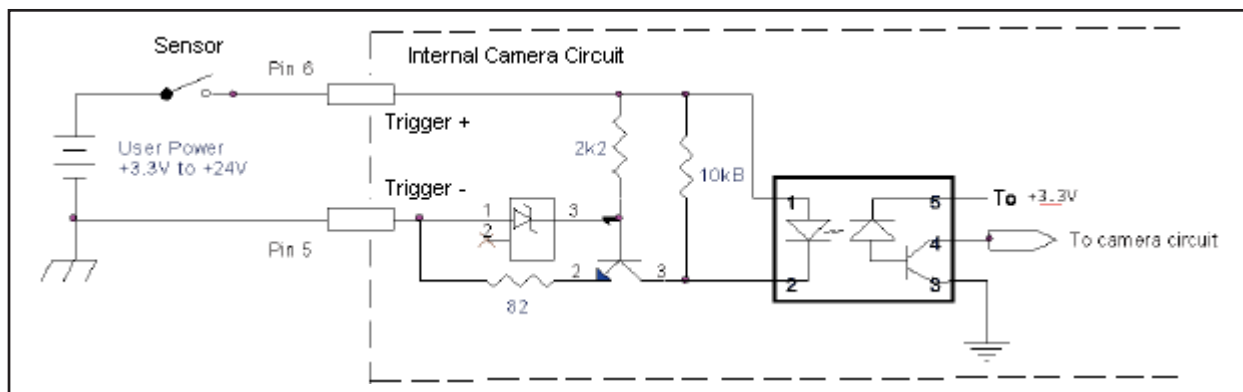

**JAI Camera Trigger Input Circuit (sinking)**

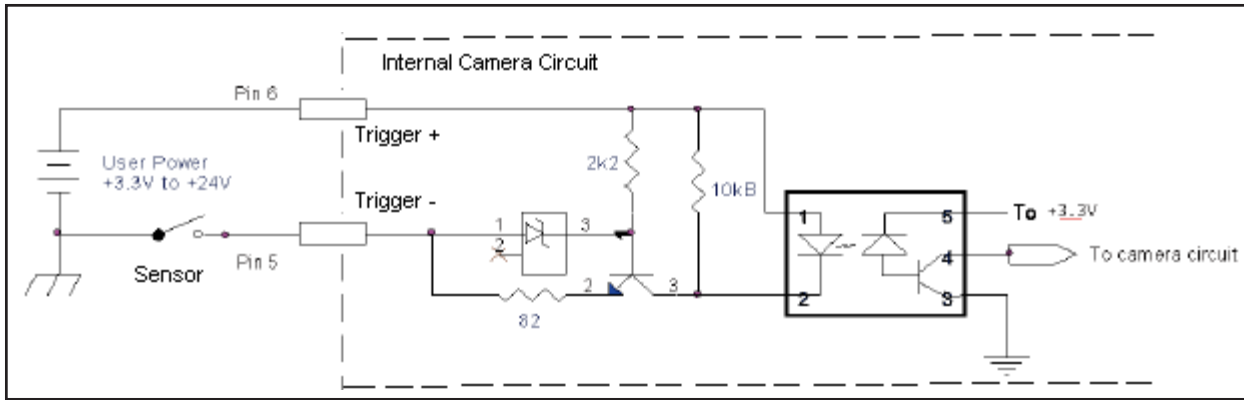

**JAI Camera Strobe Output Circuit (sinking)**

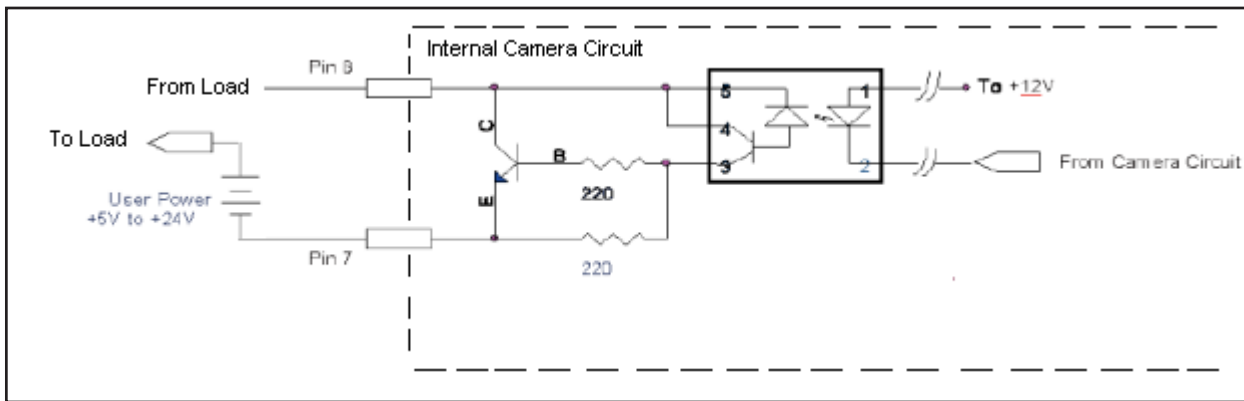

**JAI Camera Strobe Output Circuit (sourcing)**

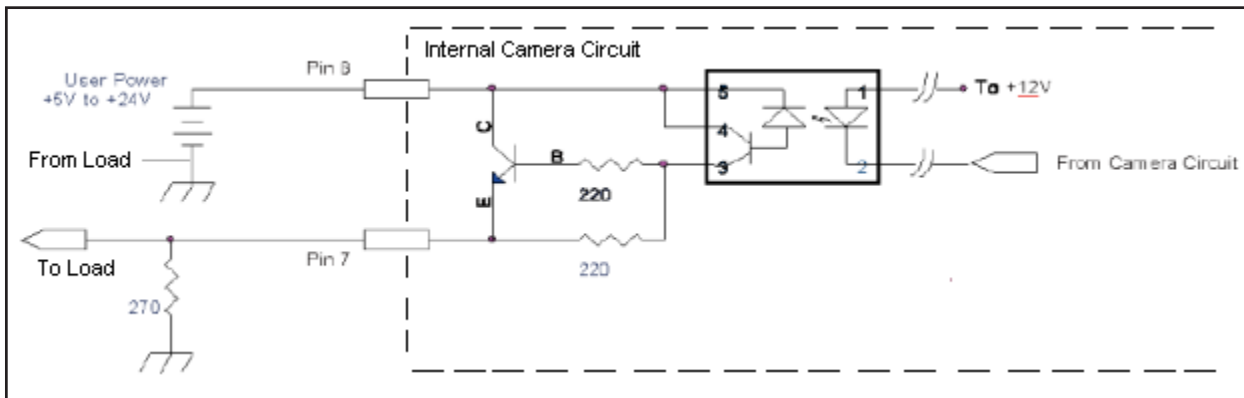

### JAI Camera Strobe Output Circuits

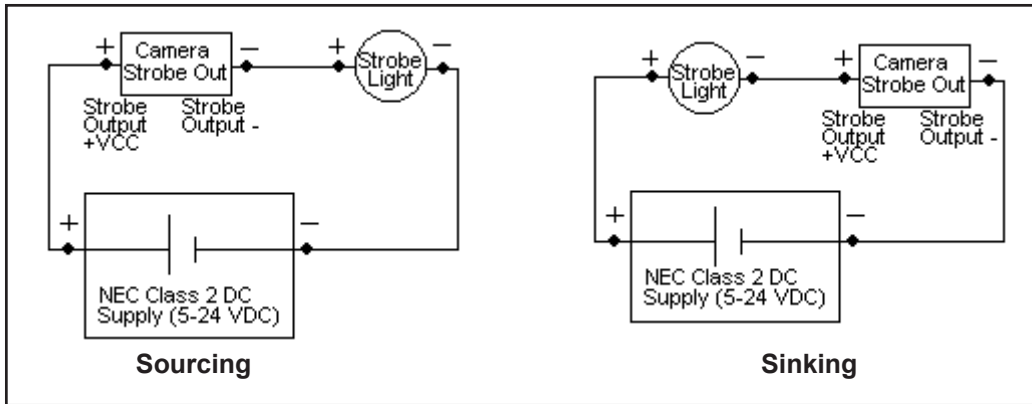

# JAI Terminal Connections

## JAI Terminal Connections (sourcing)

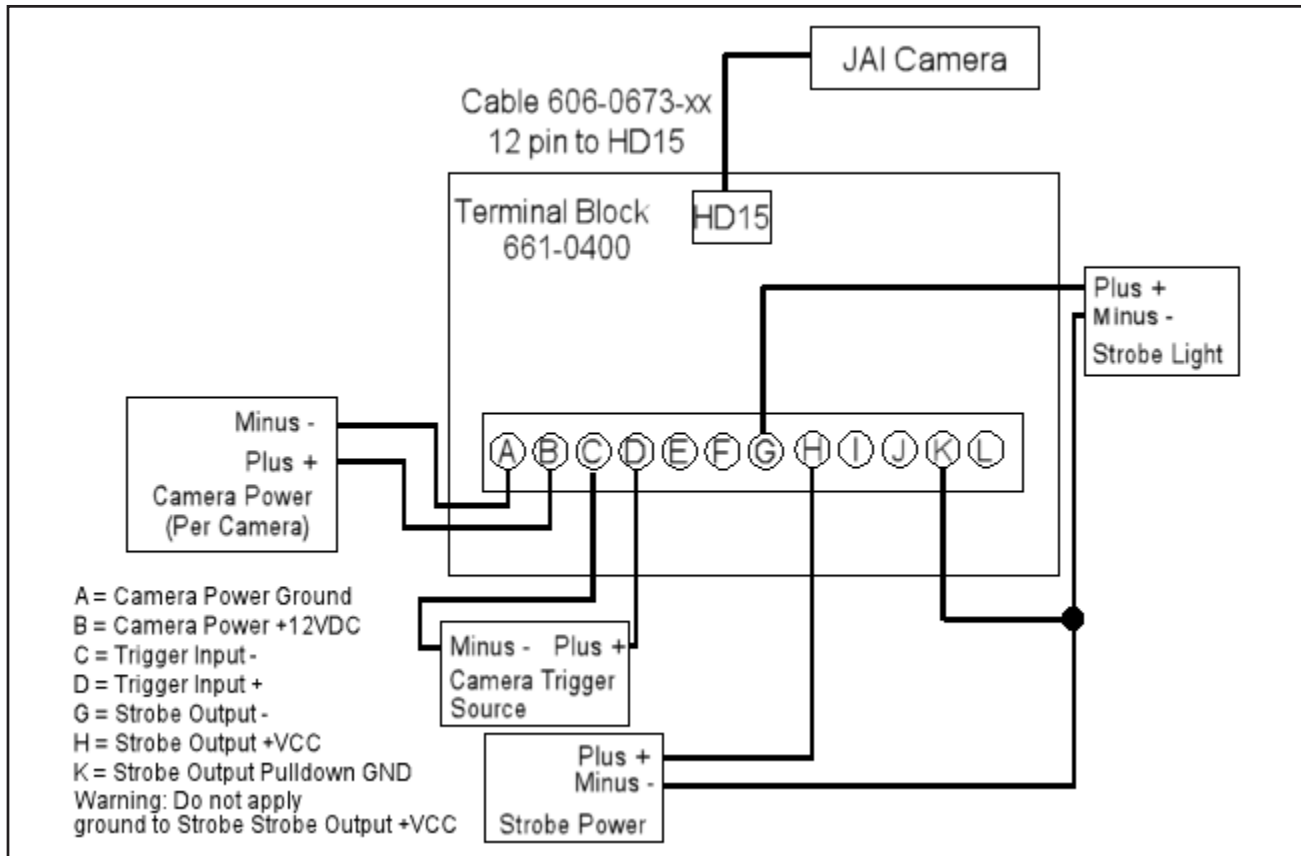



### JAI Terminal Connections (sinking)

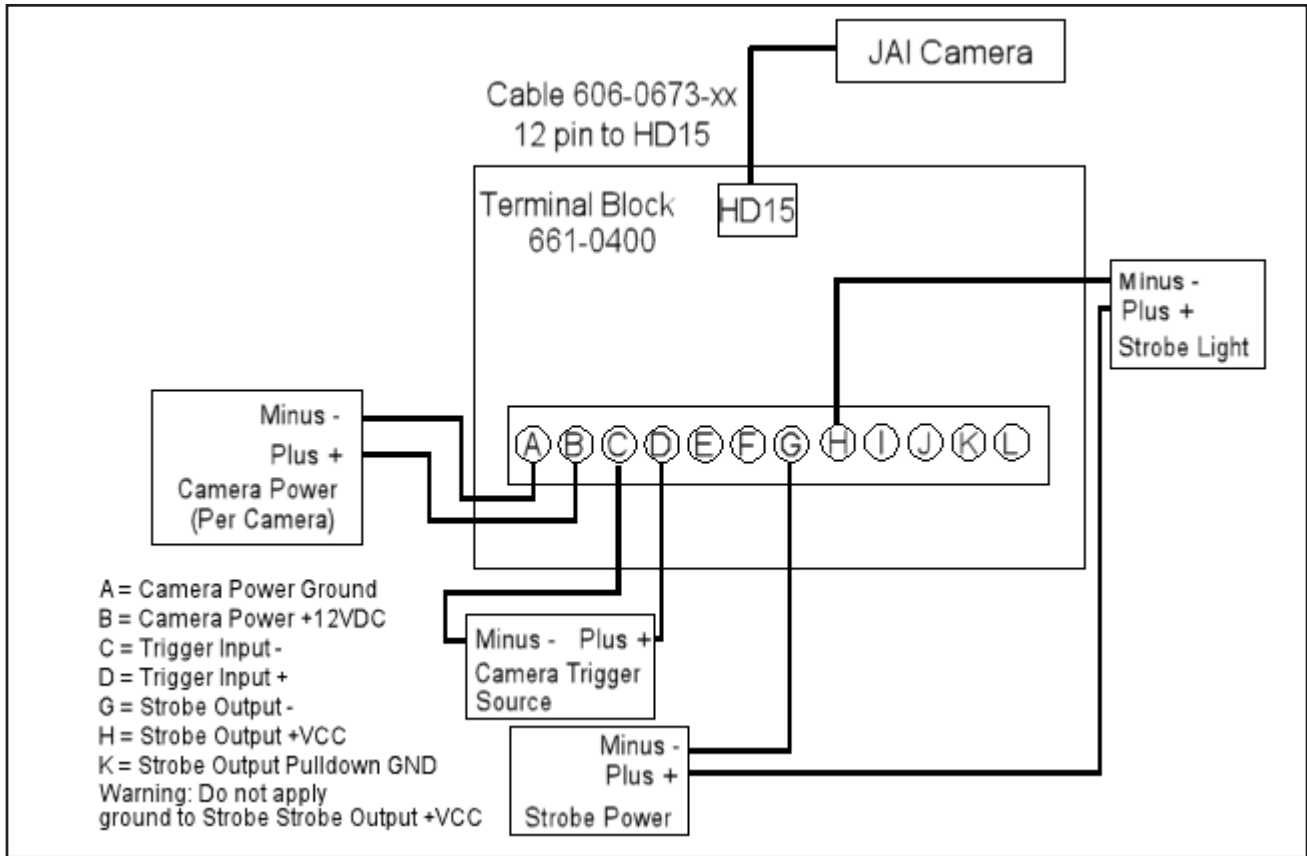

## JAI Unterminated Cable Connections

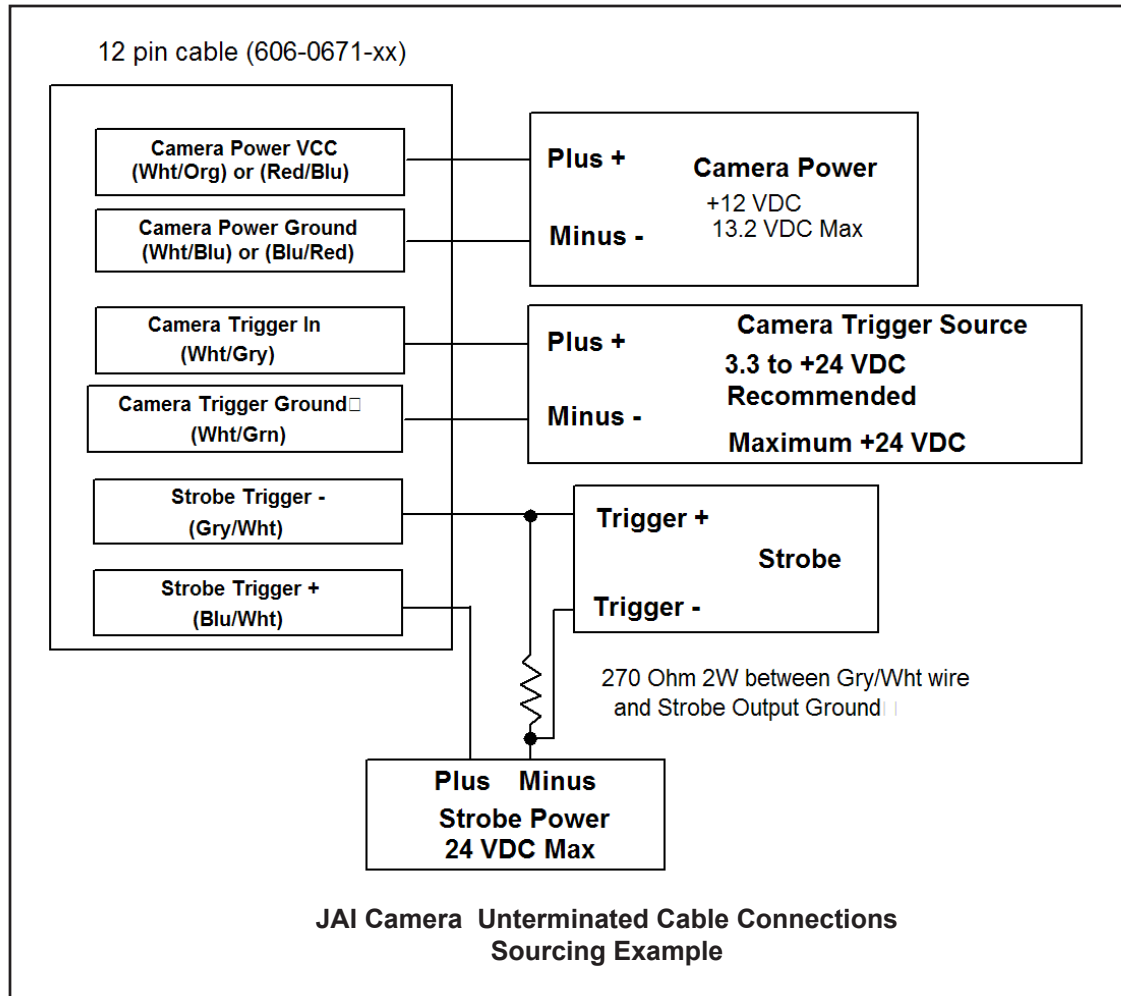

## Color shading support

The JAI Model AT-200GE camera has several special features that are not supported by the standard VPM camera setup. One of these features is color shading. Color shading corrects for image shading, particularly darkening in the corners. You can use the color shading feature of this camera after you complete the following offline calibration procedure.

### To calibrate color shading

1. Using the optics and lighting for the application, place a white or gray target that fills the field-of-view.
2. Using VPM camera settings, set the white balance to factory defaults. You should re-calibrate the white balance after the shading is corrected.
3. Adjust the exposure and other settings to create a grey level of 50 to 75% at the center of the image. Note the exposure setting.
4. Close VPM and IMPACTDevice.exe.
5. Start the Pylon Viewer by double-clicking on the following file:  
 c:\Program Files\Basler\Pylon 2.x\apps\i386\PylonViewerApp.exe  
 Note that Pylon Viewer and IMPACTDevice.exe cannot run at the same time.

6. In the Devices window, select the camera to be calibrated.
7. Switch to the Feature window.
8. Set the Transport Layer/Read Timeout and the Write Timeout to 3000.
9. Set the User Set Selector to Default and click the User Set Load button.
10. Set the Acquisition Control/Exposure Mode to Timed.
11. Set the Acquisition Control/Exposure Time to the setting found in Step 3 using VPM.
12. Snap and image using the One Shot button. An image should be displayed.
13. Verify that the image pixel values are medium intensity, not saturated or very dark. Adjust the exposure time and other settings, if necessary.
14. Move to the JAI Custom Control area of the Feature Window.
15. Select the preferred Shading Correction Mode. You will probably want Flat Shading, which corrects for both brightness variations and color variations. The other option of Color Shading will only correct for color variation and leaves brightness variation uncorrected.
16. Set Shading Selector to Red.
17. Turn On Shading Enable.
18. Click the Shading Correct Execute button.
19. Repeat steps 16, 17, and 18 for Green and Blue.
20. In the User Set Control area, set User Set Selector to User Set 1 and click the User Set Save button.
21. Close the Pylon Viewer and restart IMPACTDevice.exe and VPM.
22. The camera will now load the shading correction each time it starts.
23. Recalibrate the White Balance.

## JAI Camera I/O Signals

On JAI camera models AT200-GE and AM-800GE, the camera software setup in Vision Program Manager (VPM) provides a camera trigger delay debounce setting, but no holdoff debounce setting. VPM also does not provide a strobe trigger pulse width setting. The strobe trigger pulse width coincides with the camera shutter speed open time setting so that it turns on when the exposure starts (shutter opens) and turns off when the exposure ends (shutter closes). Refer to “Trigger Events” and “Strobe Pulse Length” in the Impact Reference Guide (843-0093) for more details.

## Basler Cameras

Model (GigE)	Resolution (Megapixels)	Color	Image Horizontal	Image Vertical	FPS (approx)	Minimum Software Version Required
avA1000-100gm avA1000-100gc	1	No Yes	1024	1024	101	10.3.0
avA1600-50gm avA1600-50gc	1	No Yes	1600	1200	55	10.3.0
avA1900-50gm avA1900-50gc	2	No Yes	1920	1080	51	10.3.0
avA2300-25gm avA2300-25gc	3	No Yes	2239	1750	26	10.3.0

## Basler Camera Connection

**WARNING: THESE CAMERAS REQUIRE +12 VDC POWER. OUR CAMERA AND OTHER THIRD-PARTY CAMERA REQUIREMENTS ARE DIFFERENT. USE CAUTION WHEN CONNECTING POWER TO THESE CAMERAS.**

To connect power, trigger signals, and strobe outputs for these Basler camera models, use cable 606-0673-xx (12-pin Hirose Male to HD-15) with terminal block 661-0400.

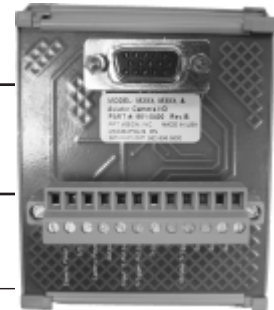

Terminal	Signal Name	Notes
Camera Power Ground	Camera Ground	
I/O Ground	I/O Ground	
Camera Power +VDC	Camera Power	+12 VDC recommended @ 500 mA Max <b>Maximum: +13.2 VDC</b>
Output +VCC	Power for Strobe Trigger Out	+3.3 to +24 VDC; 50 mA Max Maximum: +30 VDC
Input 2 Pullup +VCC	DO NOT USE	Not Currently Supported
Trigger Pullup +VCC	Trigger In Pullup - use if Trigger In needs sourcing input	Recommended: +24 VDC
Trigger In	Camera Trigger In (see Note 1 below)	0 to +24 VDC recommended Maximum +30 VDC As sinking input Off: 0 to +1.4 VDC On: +2.2 to +24 VDC; 5 to 15 ma As sourcing input (see Trigger Pullup +VCC) Off: +2.2 to +24 VDC; 5 to 15 ma On: 0 to +1.4 VDC
Input 2	DO NOT USE	Not Currently Supported
Strobe Trigger Out	Trigger Out to Strobe (see Note 2 below)	DO NOT APPLY GROUND DIRECTLY TO THIS OUTPUT.
Output 2	DO NOT USE	Not Currently Supported
Output 3	DO NOT USE	Not Currently Supported

---

Terminal	Signal Name	Notes
Output 4	DO NOT USE	Not Currently Supported

---

NOTE 1: If Camera Trigger In requires a sinking signal, set the Software Trigger Event to Rising Edge. If it requires a sourcing signal, set the Software Trigger Event to Falling Edge.

NOTE 2: If Strobe Trigger Output requires a sinking signal, set the Strobe Trigger Output to Falling Edge. If it requires a sourcing signal, set the Strobe Trigger Output to Rising Edge.

---

# Basler Circuit Diagrams

## Basler Trigger In Circuit

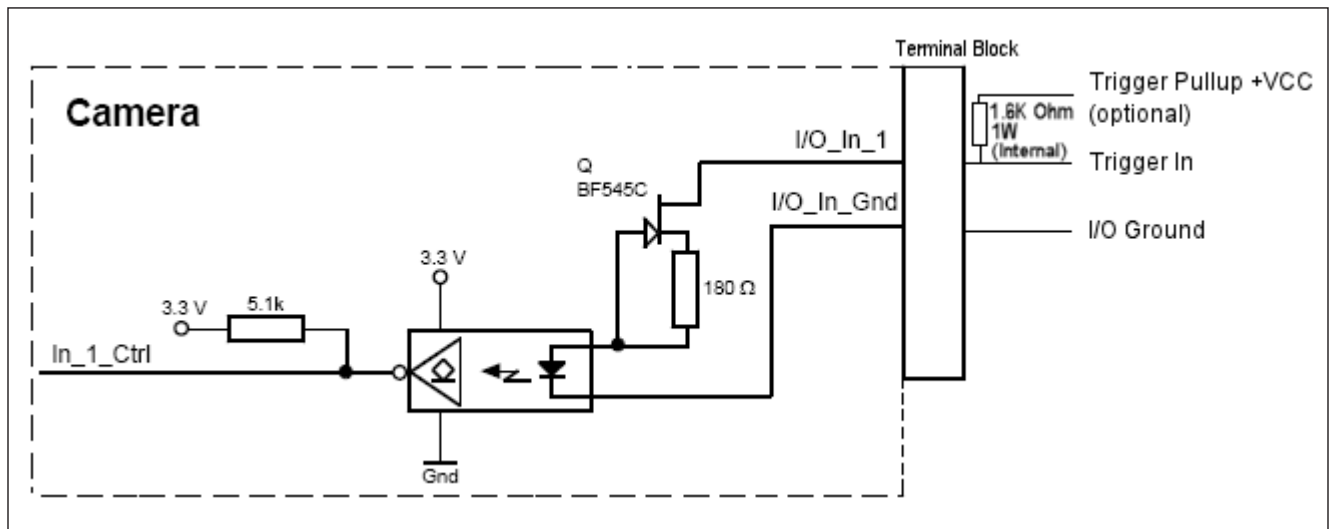

## Basler Strobe Trigger Out Circuit

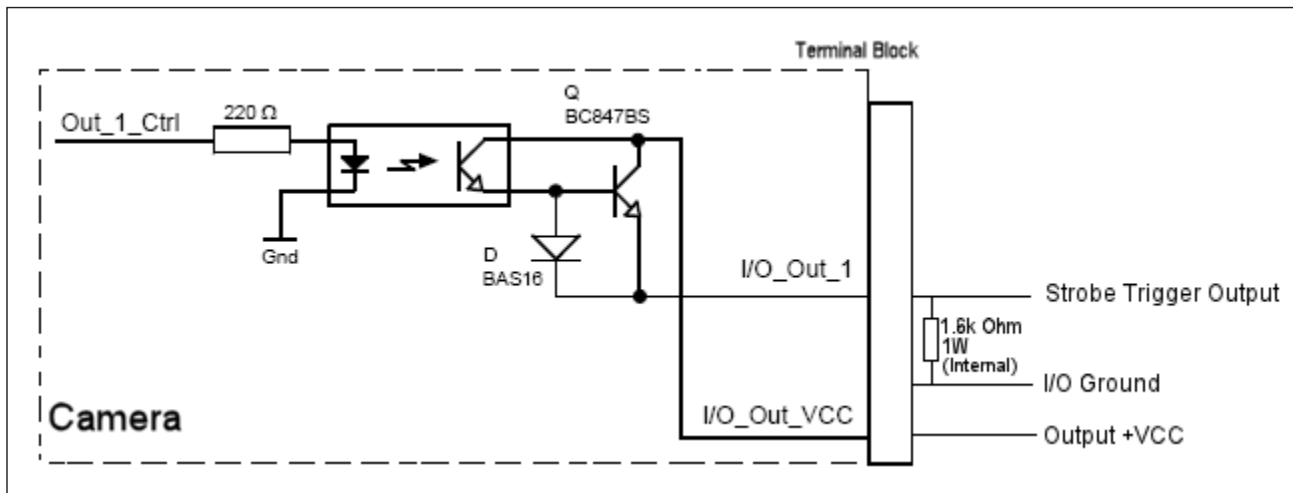

**Basler Terminal Connections**

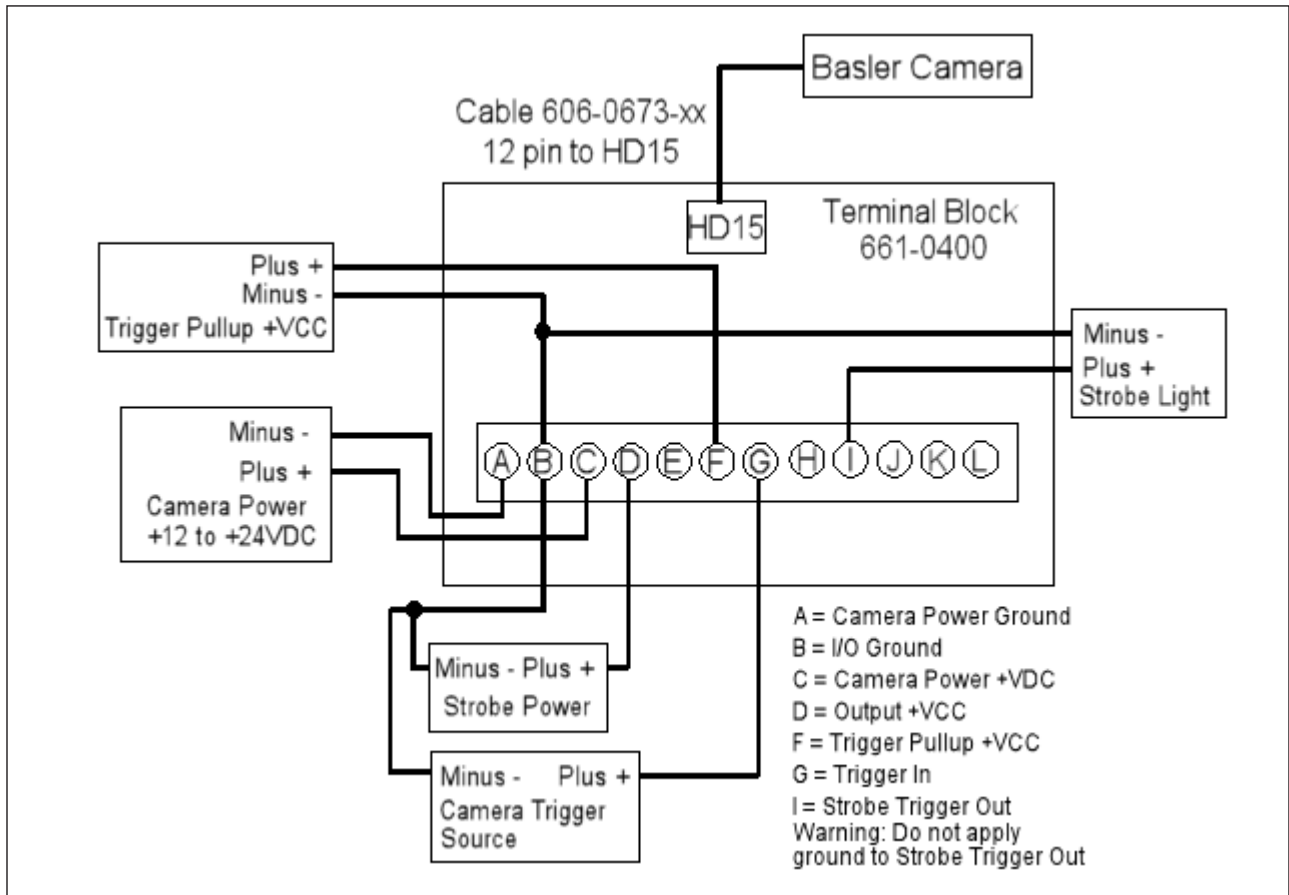

## Basler Unterminated Cable Connections

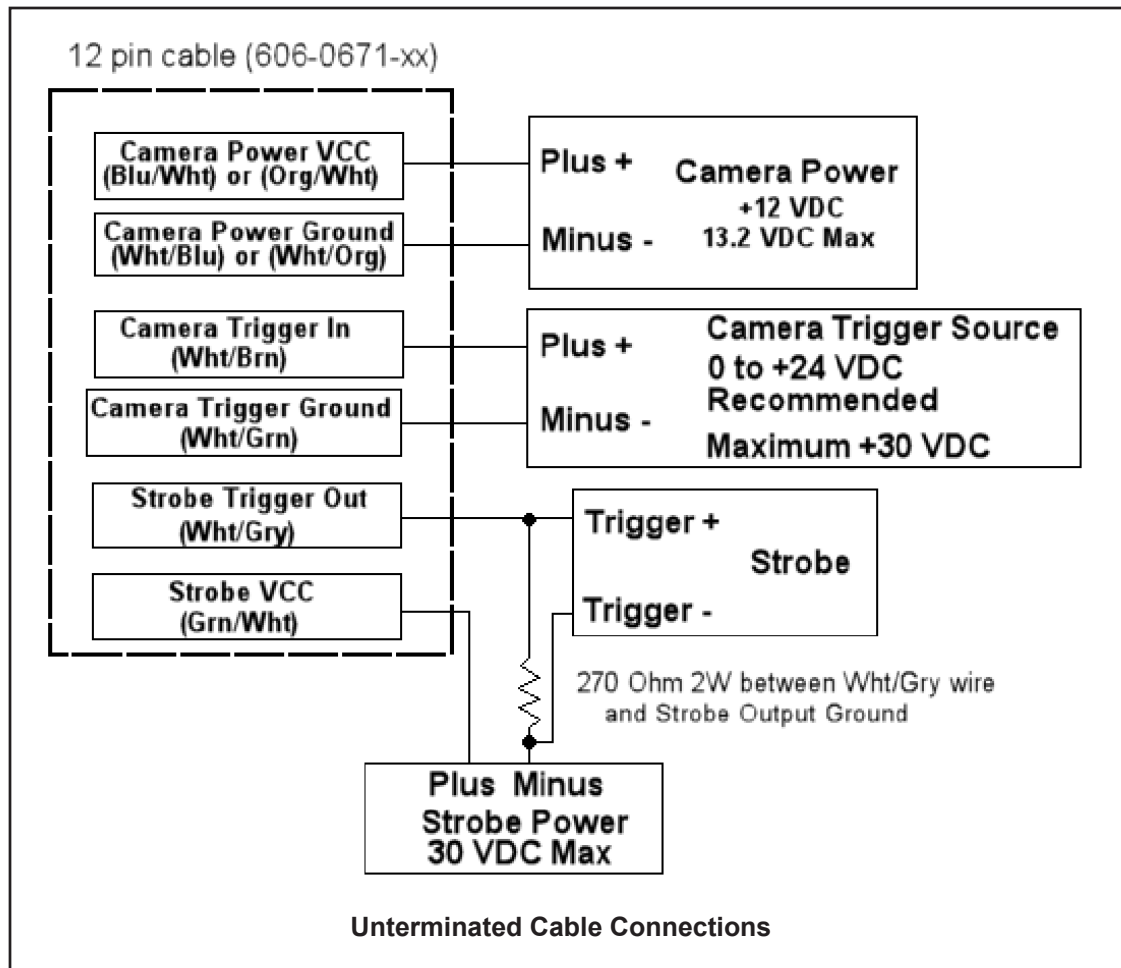



# Smartek Cameras

Model (GigE)	Resolution	Color	Image Horizontal	Image Vertical	FPS (Approx)	Minimum Software Version Required
GC651M	.3	No	659	494	120	11.1.0
GC652M	.3	No	659	494	90	11.1.0
GC653M	.3	No	659	494	90	11.1.0
GC781M	.5	No	782	682	64	11.1.0
GC1031M	.8	No	1034	770	30	11.1.0
GC1291M	1.2	No	1296	966	30	11.1.0
GC1391M	1.4	No	1392	1040	20	11.1.0
GC1392M	1.4	No	1392	1040	30	11.1.0
GC1621M	2	No	1628	1236	25	11.1.0
GC2441M	5	No	2448	2050	15	11.1.0

## Smartek Camera Connection

Camera power, trigger signal, and strobe trigger can be connected to the camera using one of two methods: a terminal block with a cable or an unterminated cable. Use a terminal block (248-0136) with the optional Hirose 12-pin to HD-15 camera cable (606-0673-xx). Without a terminal block, use the optional Hirose 12-pin to unterminated cable (part number 606-0671-xx).

NOTE: Do NOT use terminal block 248-0141 to connect this camera. It will NOT provide the correct signal levels.

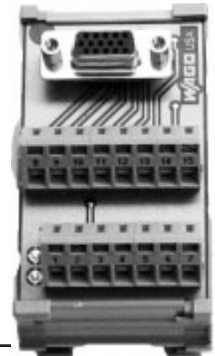

**WARNING: THE POWER AND GROUND CONNECTIONS FOR THIS CAMERA ARE DIFFERENT FROM OUR CAMERAS AND OTHER THIRD-PARTY CAMERAS. USE CAUTION WHEN CONNECTING POWER TO THESE CAMERAS.**

Terminal	Color	Signal Name	Notes
1	Wht/Blu	Camera Power Ground	
2	Wht/Org	Camera Power VCC	+12 VDC @ 300 mA Max (3.6 W) Minimum: +10 VDC Maximum: +24 VDC
3	Wht/Brn	Strobe Trigger -	270 Ohm 2W resistor between Wht/Brn wire and Strobe Power Ground
4	Brn/Wht	Strobe Trigger +	+5 to +24 VDC Maximum: +24 VDC
5	Wht/Grn	DO NOT USE	
6	Wht/Gry	DO NOT USE	
7	Gry/Wht	DO NOT USE	

Terminal	Color	Signal Name	Notes
8	Blu/Wht	DO NOT USE	
9	Org/Wht	DO NOT USE	
10	Grn/Wht	DO NOT USE	
11	Red/Blu	Camera Trigger +	+0 to +24 VDC Off: 0 to + 1.4 VDC On: +2.2 to + 24 VDC Maximum: +24 VDC
12	Blu/Red	Camera Trigger -	

## Smartek Camera Circuit Diagrams

*Smartek Camera Trigger Input Circuit*

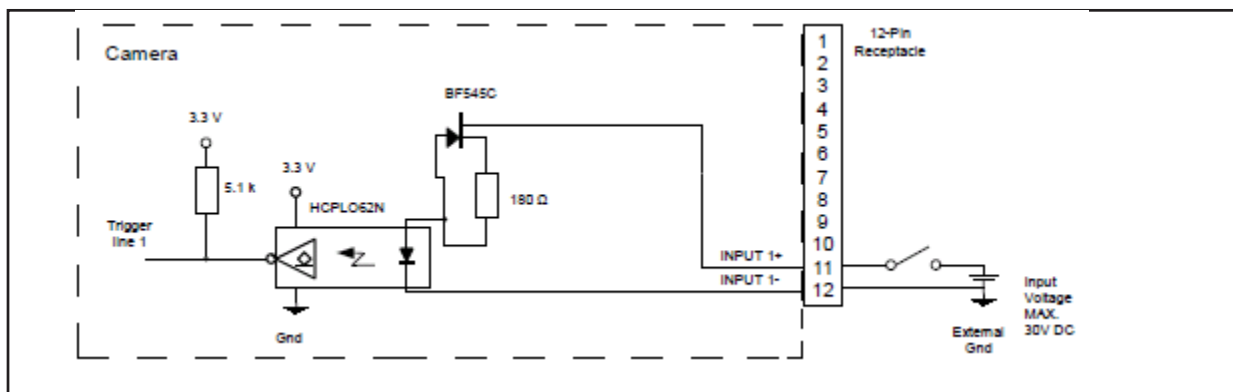

*Smartek Camera Strobe Output Circuit*

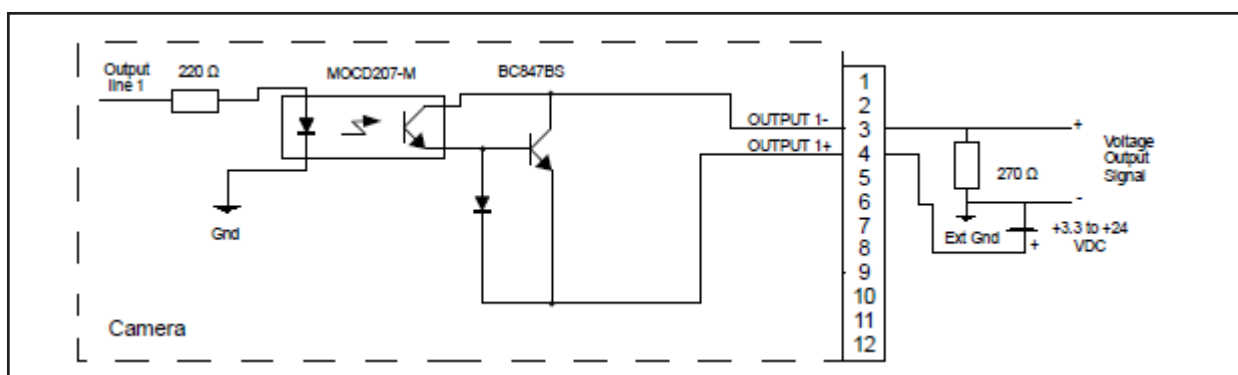

### Smartek Camera Strobe Output Circuits

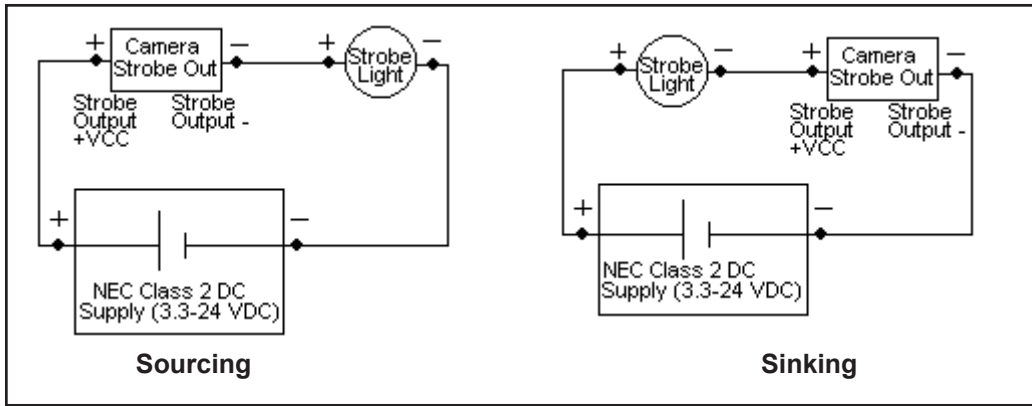

# Smartek Terminal Connections

## Smartek Terminal Connections (sourcing)

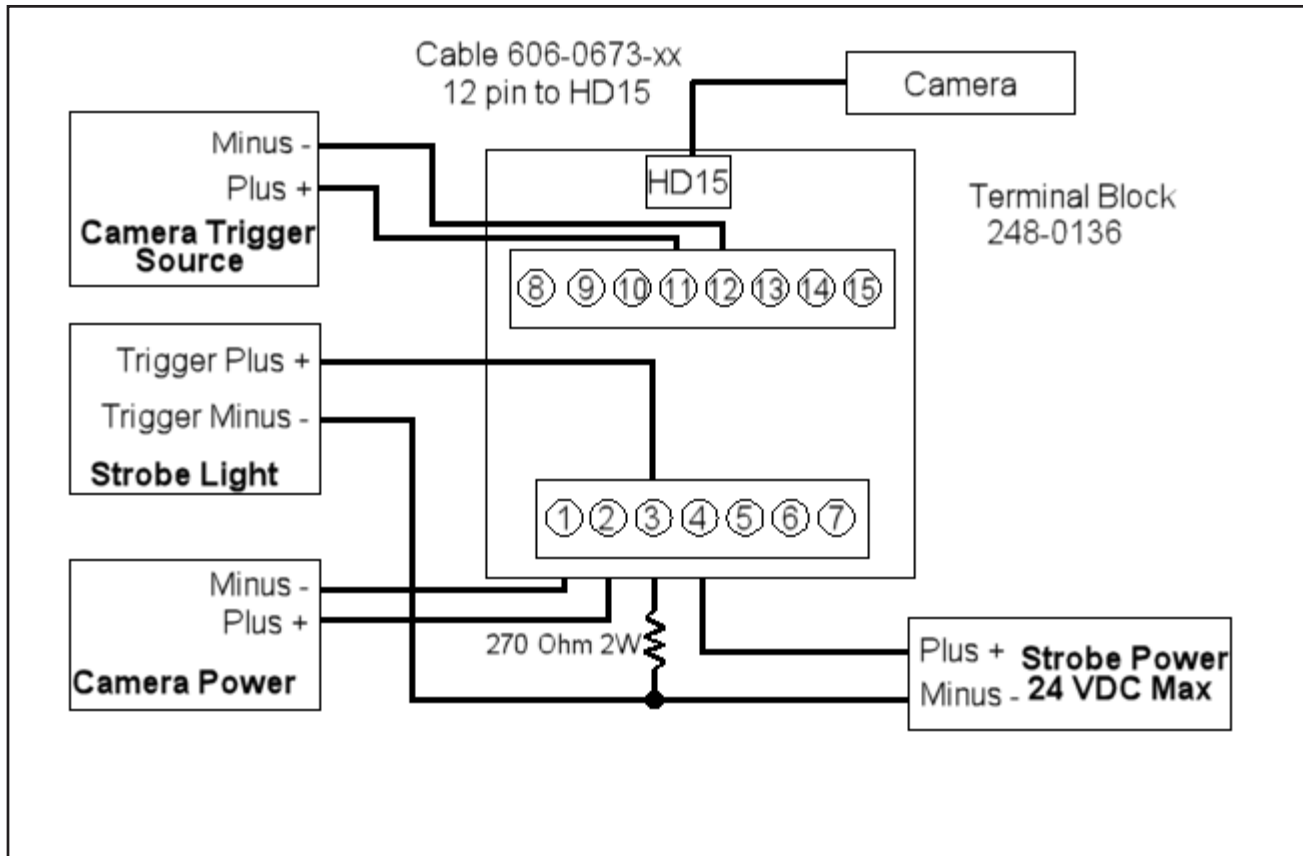

# Smartek Underterminated Cable Connections

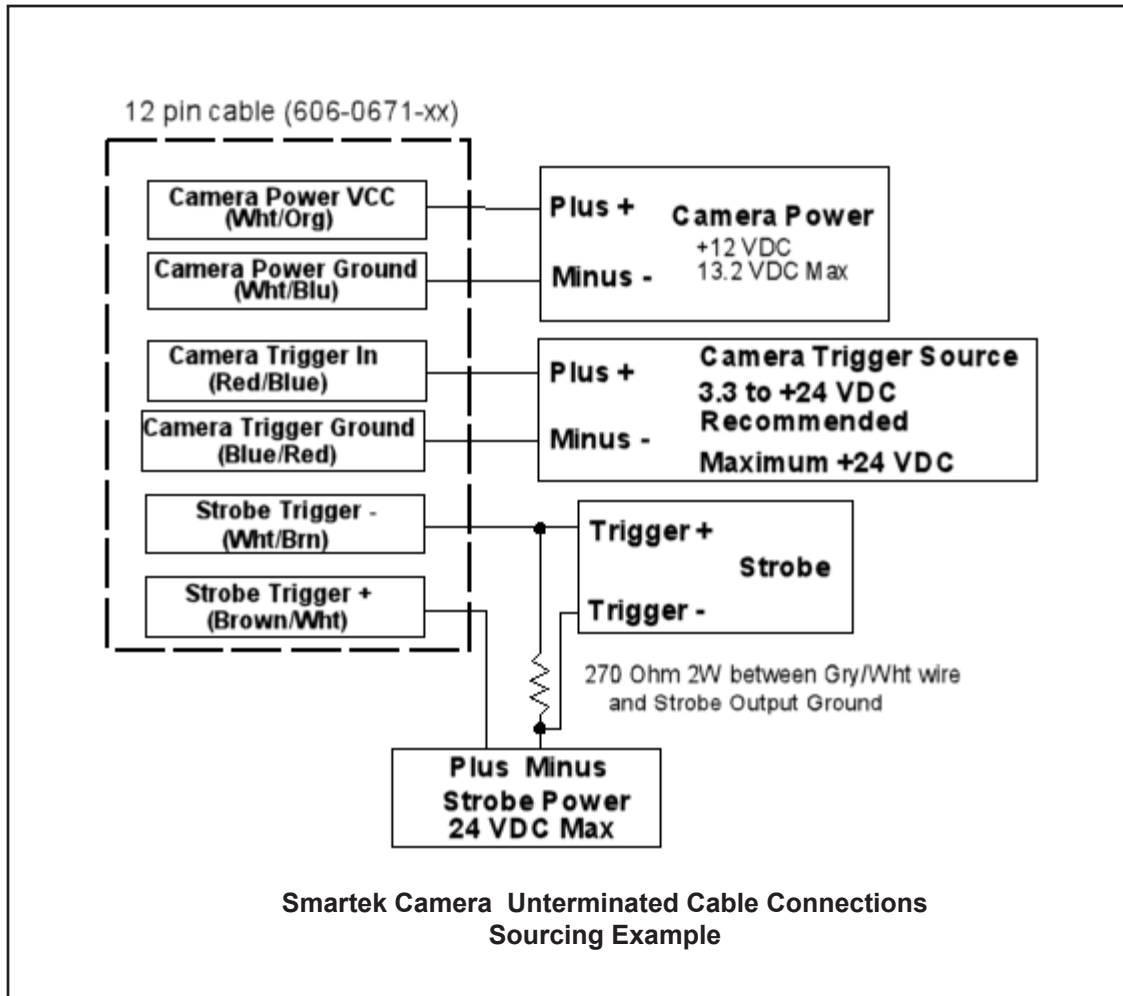

## SVS-Vistek Cameras

Model (GigE - IP67)	Resolution (Megapixels)	Color	Image Horizontal	Image Vertical	FPS (approx)	Minimum Software Version Required
eco204MVGE eco204CVGE	<1	No Yes	1024	768	47	10.4.0 10.5.0
eco267MVGE eco267CVGE	1.3	No Yes	1360	1024	25	10.4.0 10.5.0
eco274MVGE eco274CVGE	1.9	No Yes	1600	1200	25	10.4.0 10.5.0
eco285MVGE co285CVGE	1.3	No Yes	1360	1024	34	10.4.0 10.5.0
eco414MVGE eco414CVGE	<1	No Yes	640	480	125	10.4.0 10.5.0
eco415MVGE eco415CVGE	<1	No Yes	782	494	86	10.4.0 10.5.0
eco424MVGE eco424CVGE	<1	No Yes	640	480	124	10.4.0 10.5.0
eco445MVGE eco445CVGE	1.2	No Yes	1280	960	30	10.4.0 10.5.0
eco618MVGE eco618CVGE	<1	No Yes	640	480	160	10.4.0 10.5.0
eco655MVGE eco655CVGE	5	No Yes	2456	2048	10	10.4.0 10.5.0

## SVS-Vistek Camera Connection

This camera uses two cables, one for Ethernet and one for power and trigger signals. For the Ethernet connection, use cable 606-0677-xx.

To connect power and trigger signals, use a terminal block (248-0136) with the optional Hirose 12-pin to HD-15 camera cable (606-0687-xx).

Terminal	Signal Name	Notes
1 (Brown)	Camera Power	Min +10 VDC to Max +25 VDC
2 (Blue)	Camera Ground	
3 & 4	DO NOT USE	Not Currently Supported
5 (Pink)	Camera Trigger In	0 to +24 VDC
6	DO NOT USE	Not Currently Supported
7(Black)	Trigger Out to Strobe	0 to +24 VDC; 300 mA Max
8, 9, 10, 11, 12	DO NOT USE	Not Currently Supported

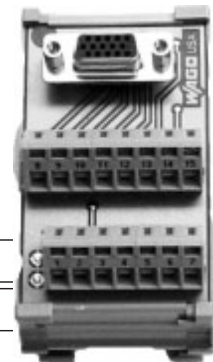

**SVS-Vistek I/O Circuit**

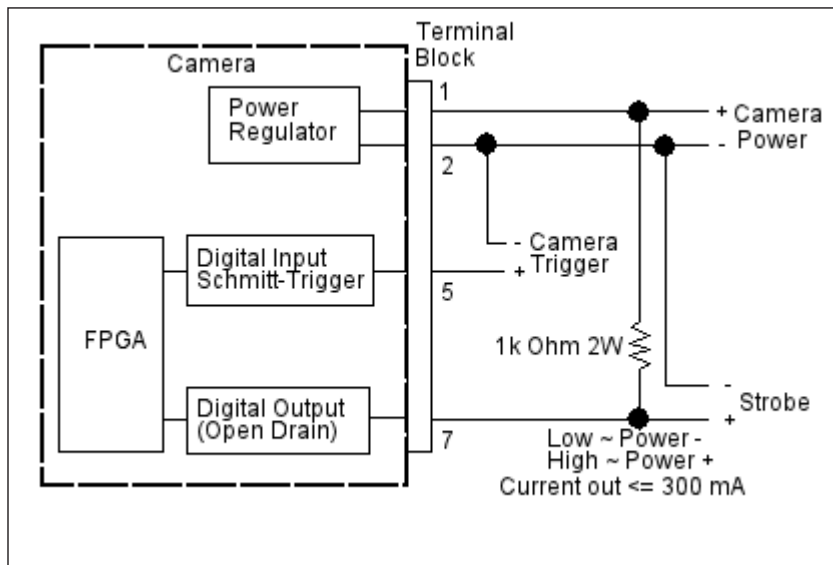

**SVS-Vistek Terminal Connections**

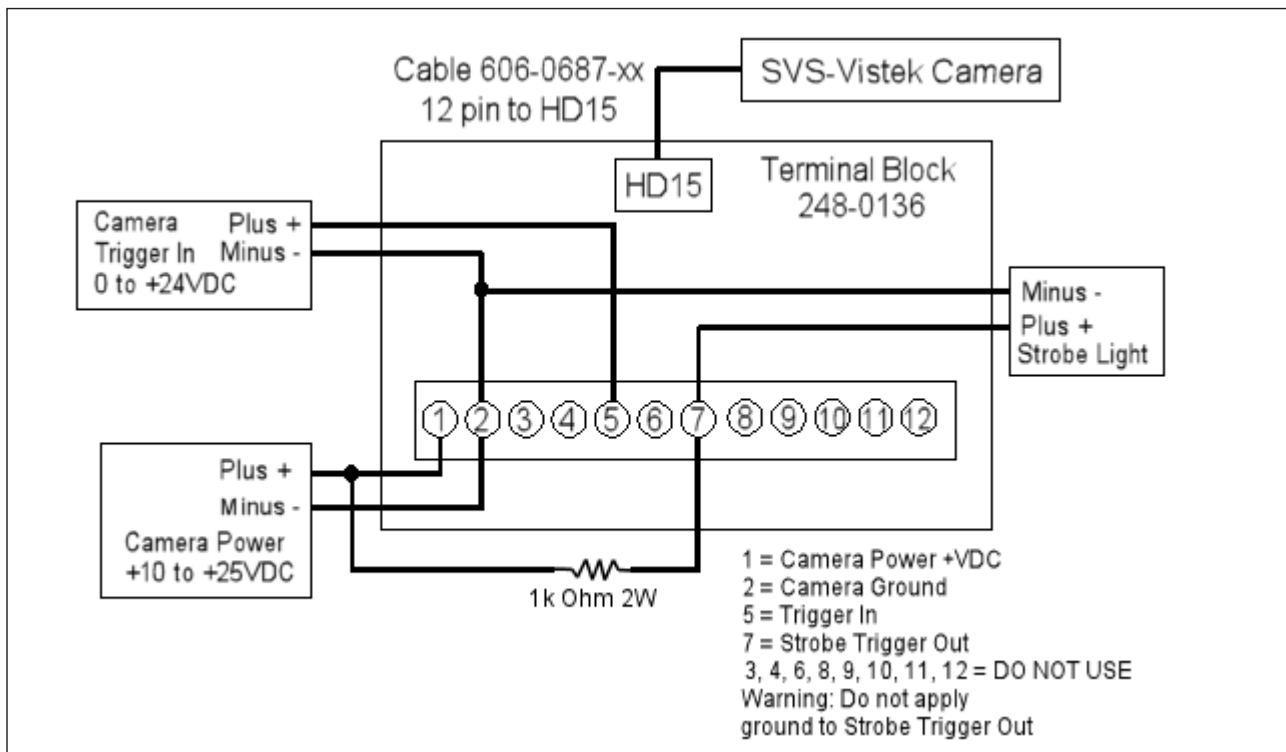

**Dalsa Cameras**

All the Dalsa® cameras here are monochrome with a GigE Vision interface. Order a lens adapter with the camera.

Model	Width	Pixel Size (µm)	Maximum Line Rate (khz)	Minimum Software Version Required*
-------	-------	-----------------	-------------------------	------------------------------------

SG-14-01K40	1k	14	36	10.6.0
SG-14-01K80	1k	14	68	10.6.0
SG-14-02K40	2k	14	18	10.6.0
SG-14-02K80	2k	14	36	10.6.0
SG-14-04K80	4k	10	18.5	10.6.0

\*NOTE: To operate these cameras, an MX-Series processor with Windows 7 64-bit operating system is required. The MX80 processor with 8 Gb of memory is required when using two of these cameras on one system.

## Dalsa Camera Connection

This camera uses three cables, one for Ethernet, one for power, and one for I/O signals. For the Ethernet connection, use cable 606-0677-xx.

**WARNING: THESE CAMERAS REQUIRE +12 VDC POWER. OUR CAMERA AND OTHER THIRD-PARTY CAMERA REQUIREMENTS ARE DIFFERENT. USE CAUTION WHEN CONNECTING POWER TO THESE CAMERAS.**

### Power Connection

To connect power, use the optional 6 pin Hirose pigtail cable (606-0672-xx). Do NOT use the M1xx terminal block (661-0399) because it has internal pullup resistors.

Power Cable Pin Number and Color	Signal Name	Notes
1 (Blue) 2 (Orange) 3 (Green)	Camera Power	Min +12 VDC to Max +15 VDC @ 750 mA Max
4 (Wht w/Grn) 5 (Wht w/Org) 6 (Wht w/Blu)	Camera Ground	

### I/O Connection

To connect I/O signals, use a terminal block (248-0136) with the optional 15 pin HD cable (606-0568-xx).

I/O Terminal Block Number	Signal Name	Notes
1 Input 0 +	Single Line Trigger <b>OR</b> Phase A Line Trigger (Quadrature Encoder) See Note 2 below and "Dalsa Scan Direction" on page 3-41	As sinking input Off 0 to +0.66 VDC On: +2.6 to +5 VDC As sourcing input Off: +2.6 to +5 VDC On 0 to +0.66 VDC Maximum: +5 VDC
2 Input 0 -	LVDS mode differential	See Note 1 below



I/O Terminal Block Number	Signal Name	Notes
3 Input 1 +	Frame Start Trigger	As sinking input Off 0 to +0.66 VDC On: +2.6 to +5 VDC As sourcing input Off: +2.6 to +5 VDC On 0 to +0.66 VDC Maximum: +5 VDC
4	No Connection	DO NOT USE
5	Camera Ground	Input minus for all Inputs when TTL Mode is selected Isolated from Power Ground
6 Input 2 +	Scan Direction <b>OR</b> Phase B Line Trigger (Quadrature Encoder) See Note 2 below and “Dalsa Scan Direction” on page 3-41	As sinking input Off 0 to +0.66 VDC On: +2.6 to +5 VDC As sourcing input (see Input 3 Pullup) Off: +2.6 to +5 VDC On 0 to +0.66 VDC Maximum: +5 VDC
7 Input 2 -	LVDS mode differential	See Note 1 below
8 through 15	No Connection	DO NOT USE

---

Note 1: The Trigger inputs can operate using TTL (Transistor/Transistor Logic) or LVDS (Low Voltage Differential Signal). The mode is selected in VPM in Settings - Camera - Line Scan tab. To select TTL mode, clear the Input Termination check box. To select LVDS mode, check the check box. Frame Start Trigger always uses TTL mode.

---



---

Note 2: The Line Trigger mode is selected in VPM in Settings - Camera - Line Trigger tab below

---

## Dalsa Scan Direction

It is important to understand the scan direction of the Dalsa line scan camera. The camera has a two-line sensor capable of TDI (Time Delay Integration). An image row is exposed with one line of the sensor, then shifted and exposed again with the other line of the sensor, while the next row of the image is being exposed in the first sensor line. This doubles the net exposure time without slowing the line rate. In order to operate in this mode, the camera must know which of the two lines of the sensor is exposed first. This is determined by the scan direction input (Input 2). If this setting is wrong, the image will be blurred in the vertical direction.

In Single Phase line trigger mode, Input 2 controls the scan direction. When input 2 is high, the sensor lines are shifted in the “forward” direction. When input 2 is low, the sensor lines are shifted in the “reverse” direction. If the scan direction never changes, you can hard wire Input 2 high or low, depending on how the camera is mounted.

In Quadrature Phase line trigger mode, Input 2 triggers Phase B and Input 0 triggers Phase A. The sensor lines are shifted in the “forward” direction when Phase A leads Phase B and shifted in the reverse direction when Phase A trails Phase B.

Physically, the forward direction for the 1K and 2K Dalsa line scan cameras runs from the top of the camera towards the bottom of the camera (from the I/O connector towards the power connector). In the 4K line scan camera, the forward direction is from the power connector towards the Ethernet connector.

If the part is moving from the bottom of the camera towards the top of the camera, Input 2 should be high (or encoder Phase A should lead Phase B).

## Dalsa Frequency Converter

The Dalsa camera has a frequency converter for the Line Trigger input. It has a multiplier and a divider, but not a pre-divider. The multiplier value is fixed at 256. The divider value can be adjusted to any value between 1 and 65535, so it allows for 0.25% accuracy in setting the pixel height.

## Dalsa Acquisition Modes

Dalsa cameras support four frame trigger modes: Single Frame Edge Triggered, Continuous While Frame Trigger High, Continuous While Frame Trigger Low, and Continuous While Online.

In the Continuous While Frame Trigger High and Continuous While Frame Trigger Low modes, the Dalsa camera acquires images of the normal image height while the frame trigger is active. These cameras have a maximum image height of 16,383 lines.

The Top Edge value is always 1 and the Bottom Edge is the number of lines to acquire. You can adjust the maximum image height and width in VPM in Settings - Camera - Partial Scan tab.

When the frame trigger goes inactive, the camera immediately sends the current image to the vision program with the number of lines that have been acquired. It is up to the vision program to discard or attempt to process the partial height image. The height of the current image can be accessed programmatically in the image's Height property in VPM.

The M5xx cameras do not work this way. The M5xx cameras pause acquisition when the frame trigger is inactive and then continue acquisition when the frame trigger goes active again, so that all images are the full height. The top of the image does not necessarily correspond to the beginning of the frame trigger.

## Dalsa Shutter / Exposure

The Dalsa camera is automatically configured for timed shutter mode. The shutter time, which can be adjusted in VPM in Settings - Camera - General tab, is the exposure time PER LINE, just like the M5xx cameras.

When the system is Online, the Line Trigger starts the exposure for each line, so it is very important that the line trigger period be longer than the shutter time. If the line trigger rate is too fast, then some triggers will be ignored.

When the system is Offline and you are using the Snap, Live, or Trigger buttons, the line triggers are internally generated by the camera at the rate of the shutter time. This allows you to acquire images without wiring any inputs, although the images will be distorted because the line trigger rate is different. You can only see accurate images when the system is Online.

## Camera Setup and Calibration

Use the Impact programs to setup and calibrate cameras with an M-Series processor. (Refer to the Camera Setup Tab section of the Impact Software Reference Guide.) For more detailed information about third-party cameras, consult the manufacturer's documentation for those cameras.

Calibration insures that measurements shown in Impact software tools accurately indicate the inspected object's measurements. A camera requires calibration when it is first connected to the vision device, when the camera-to-subject distance changes, and when the lens is changed. A calibration target with 0.5, 1.0, and 2.0 mm dot pitches is available from us (Part number 381-1177). Contact us for printed versions of targets with larger pitches.

# Camera Specifications

## M1xx, M1xxC

All M1xx cameras have the following specifications. Model numbers that end in “C” are color cameras.

M1xx Common Specifications	
Lens Mount	C mount
Cabling	Camera cable provides power and trigger. Ethernet cable transmits video
Operating Environment	Temperature: 0 to +50 C (+32 to 122 F) Humidity: 0 to 90% (non-condensed)
Vibration	5g (11 to 200 Hz)
Power	12 VDC provided by camera cable (2 Watts) or Power Over Ethernet (2.3 Watts)
Weight	3.2 ounces (~90 g)
Software Version	Impact Software V10.0 or greater

## M100, M100C

This camera captures a 659 x 494 pixel size image with square pixels. It can partially scan the image horizontally and vertically.

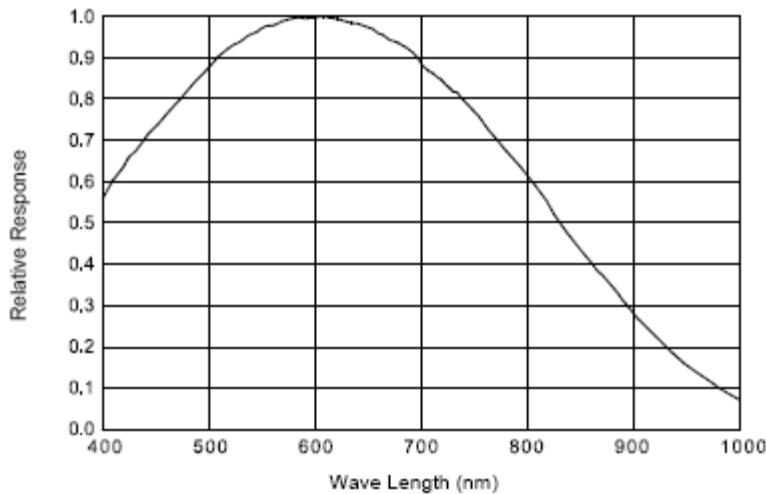

M100 Spectral Response (excludes lens and light source characteristics)

M100 Specifications	
Part Number	601-0351; 601-0378
Pick-up Device	Progressive Scan CCD - 659 (H) x 494 (V) pixels
Sensor Size	1/4" (4.5 mm) diag - 3.58mm (H) x 2.68mm (V)
Capture Rate	100 full-resolution fps; higher with partial scan

<b>M100 Specifications</b>	
Pixel Size	5.6 x 5.6 micrometers
Gain	100% to 1023%
Shutter Open	16 to 1,000,000 microseconds
Exposure Start Delay	17.62 $\mu$ sec

## M110, M110C

This camera captures a 659 by 494 pixel size image with square pixels. It can partially scan the image horizontally and vertically. (Impact Software V10.3.0 or greater)

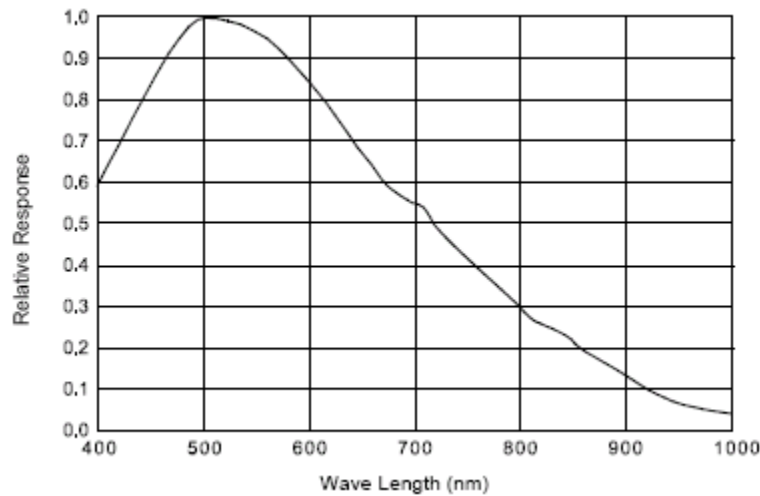

M110 Spectral Response (excludes lens and light source characteristics)

<b>M110 Specifications</b>	
Part Number	601-0423; 601-0424
Pick-up Device	Progressive Scan CCD - 659 (H) x 494 (V) pixels
Sensor Size	1/3" (6 mm) diagonal - 4.80mm (H) x 3.60mm (V)
Capture Rate	90 full-resolution fps; higher with partial scan
Pixel Size	7.4 x 7.4 micrometers
Gain	350% to 1023%
Shutter Open	24 to 1,000,000 microseconds
Exposure Start Delay	31.72 $\mu$ sec

## M115, M115C

This camera captures a 659 by 494 pixel size image with square pixels. It can partially scan the image horizontally and vertically. (Impact Software V10.5.0 or greater)

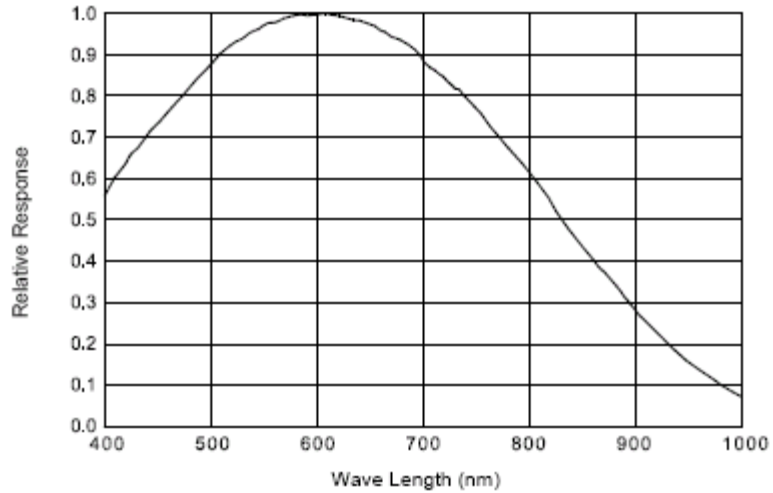

M115 Spectral Response (excludes lens and light source characteristics)

<b>M115 Specifications</b>	
Part Number	601-0450; 601-0451
Pick-up Device	Progressive Scan CCD - 659 (H) x 494 (V) pixels
Sensor Size	1/2" (8 mm) diag - 6.52 (H) mm x 4.89 mm (V)
Capture Rate	100 full-resolution fps; higher with partial scan
Pixel Size	9.9 x 9.9 micrometers
Gain	350% to 1023%
Shutter Open	24 to 1,000,000 microseconds
Exposure Start Delay	17.62 $\mu$ sec

## M125, M125C

This camera captures a 782 by 582 pixel size image with square pixels. It can partially scan the image horizontally and vertically. (Impact Software V10.5.0 or greater)

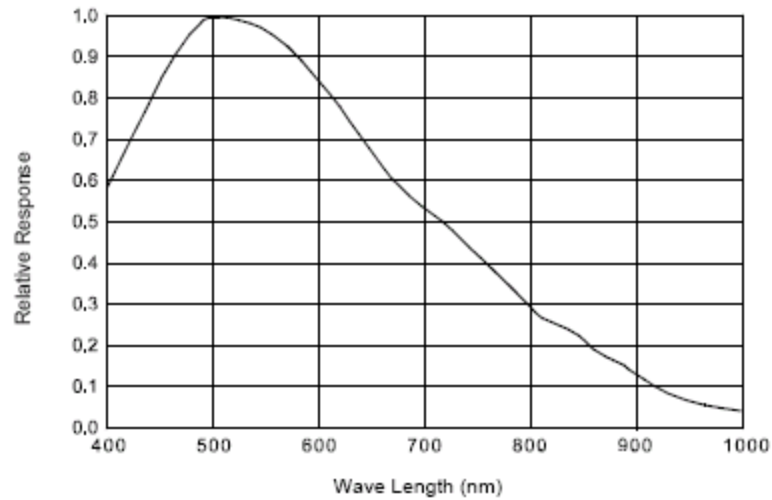

M125 Spectral Response (excludes lens and light source characteristics)

<b>M125 Specifications</b>	
Part Number	601-0452; 601-0453
Pick-up Device	Progressive Scan CCD - 659 (H) x 494 (V) pixels
Sensor Size	1/2" (8 mm) diag - 6.33mm (H) × 4.75mm (V)
Capture Rate	75 full-resolution fps; higher with partial scan
Pixel Size	8.3 x 8.3 micrometers
Gain	350% to 1023%
Shutter Open	24 to 1,000,000 microseconds
Exposure Start Delay	48.97 μsec

## M150, M150C

This camera captures a 1296 by 966 pixel size image with square pixels. It can partially scan the image horizontally and vertically.

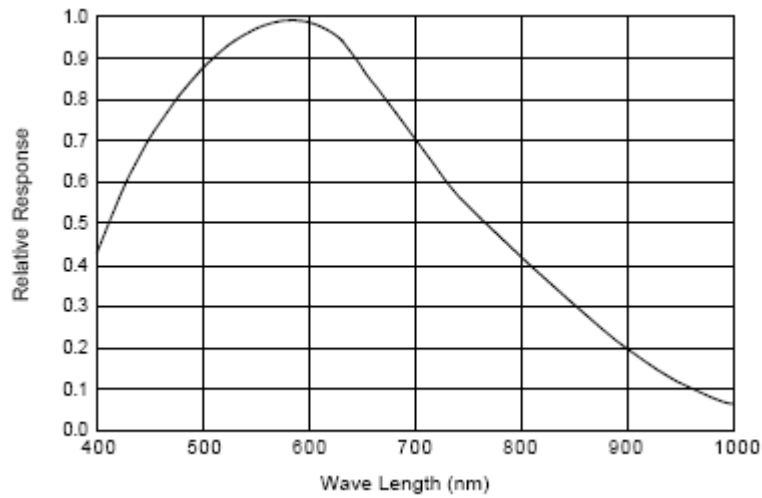

M150 Spectral Response (excludes lens and light source characteristics)

<b>M150 Specifications</b>	
Part Number	601-0352; 601-0379
Pick-up Device	Progressive Scan CCD - 1296 (H) x 966 (V) pixels
Sensor Size	1/3" (6 mm) diagonal - 4.80mm (H) x 3.60mm (V)
Capture Rate	30 full-resolution fps; higher with partial scan
Pixel Size	3.75 x 3.75 micrometers
Gain	100% to 1023%
Shutter Open	22 to 1,000,000 microseconds
Exposure Start Delay	34.50 $\mu$ sec

## M180, M180C

This camera captures a 1628 by 1236 pixel size image with square pixels. It can partially scan the image horizontally and vertically.

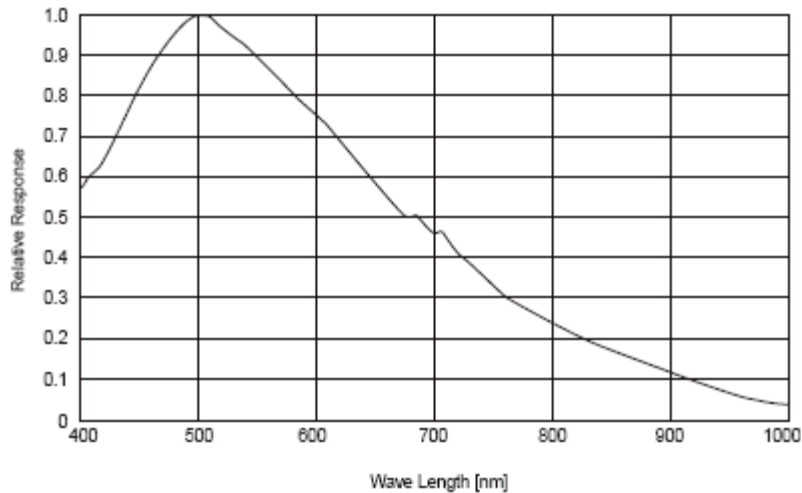

M180 Spectral Response (excludes lens and light source characteristics)

<b>M180 Specifications</b>	
Part Number	601-0357; 601-0384
Pick-up Device	Progressive Scan CCD - 1628 (H) x 1236 (V) pixels
Sensor Size	1/1.8" (8.923 mm) diag - 7.04mm (H) x 5.28mm (V)
Capture Rate	20 full-resolution fps; higher with partial scan
Pixel Size	4.4 x 4.4 micrometers
Gain	100% to 1023%
Shutter Open	31 to 1,000,000 microseconds
Exposure Start Delay	34.50 $\mu$ sec



## M190, M190C

This camera captures a 2048 by 1088 pixel size image with square pixels. It can partially scan the image horizontally and vertically. (Impact Software V10.5.0 or greater)



M190 Spectral Response (excludes lens and light source characteristics)

<b>M190 Specifications</b>	
Part Number	601-0454; 601-0455
Pick-up Device	CMOS - 2048 (H) x 1088 (V) pixels
Sensor Size	2/3" (8.923 mm) diag - 7.04mm (H) x 5.28mm (V)
Capture Rate	50 full-resolution fps; higher with partial scan
Pixel Size	5.5 x 5.5 micrometers
Gain	100% to 1023%
Shutter Open	31 to 1,000,000 microseconds
Exposure Start Delay	34.50 $\mu$ sec

## M195, M195C

This camera captures a 2048 by 2048 pixel size image with square pixels. It can partially scan the image horizontally and vertically. (Impact Software V10.5.0 or greater)



M195 Spectral Response (excludes lens and light source characteristics)

<b>M195 Specifications</b>	
Part Number	601-0456; 601-0457
Pick-up Device	CMOS - 2048 (H) x 2048 (V) pixels
Sensor Size	1" (14.8 mm) diag - 11.84 mm (H) x 8.88 mm (V)
Capture Rate	25 full-resolution fps; higher with partial scan
Pixel Size	5.5 x 5.5 micrometers
Gain	100% to 1023%
Shutter Open	31 to 1,000,000 microseconds
Exposure Start Delay	34.50 $\mu$ sec

## M2xx, M2xx-RA, M2xxC, M2xxC-RA

All M2xx, M2xx-RA, M2xxC, and M2xxC-RA cameras have the following specifications. Model numbers that include a “C” are color cameras. Model numbers that end in “-RA” are right-angle mount cameras.

M2xx Common Specifications	
Lens Mount	C mount
Cabling	Camera cable provides power and trigger. Ethernet cable transmits video
Operating Environment	Temperature: 0 to +50 C (+32 to 122 F) Humidity: 0 to 90% (non-condensed)
Vibration	5g (11 to 200 Hz)
Weight	5.4 ounces (~150 g)
Software Version	Impact Software V10.0 or greater

## M200 line

This camera line captures a 659 by 494 pixel size image with square pixels. It can partially scan the image horizontally and vertically.

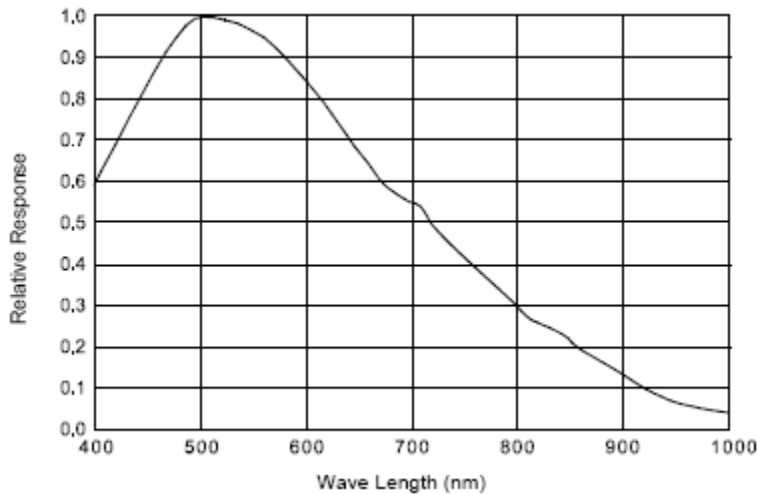

M200 Spectral Response (excludes lens and light source characteristics)

M200 Specifications	
Part Number	601-0358; 601-0358-RA; 601-0385; 601-0385-RA
Pick-up Device	Progressive Scan CCD - 659 (H) x 494 (V) pixels
Sensor Size	1/3" (6 mm) diag - 4.73mm (H) x 3.55mm (V)
Capture Rate	70 full-resolution fps; higher with partial scan
Pixel Size	7.4 x 7.4 micrometers
Gain	350% to 1023%
Shutter Open	24 to 1,000,000 microseconds

M200 Specifications	
Exposure Start Delay	31.72 $\mu$ sec
Power	24 VDC provided by camera cable (3 Watts)

## M202 line

This camera line captures a 659 by 494 pixel size image with square pixels. It can partially scan the image horizontally and vertically.

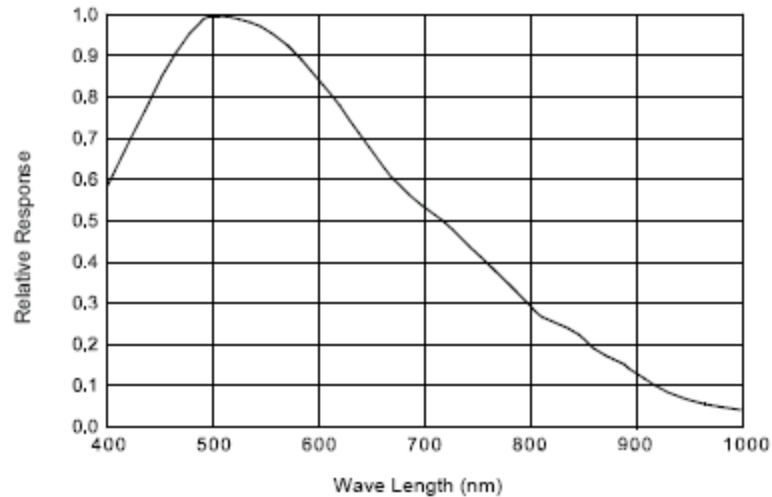

M202 Spectral Response (excludes lens and light source characteristics)

M202 Specifications	
Part Number	601-0359; 601-0359-RA; 601-0386 ;601-0386-RA
Pick-up Device	Progressive Scan CCD - 659 (H) x 494 (V) pixels
Sensor Size	1/2" (8 mm) diag - 6.33mm (H) x 4.75mm (V)
Capture Rate	79 full-resolution fps; higher with partial scan
Pixel Size	9.9 x 9.9 micrometers
Gain	100% to 1023%
Shutter Open	24 to 1,000,000 microseconds
Exposure Start Delay	28.19 $\mu$ sec
Power	24 VDC provided by camera cable (3 Watts)

## M210 line

This camera line captures a 782 by 582 pixel size image with square pixels. It can partially scan the image horizontally and vertically.

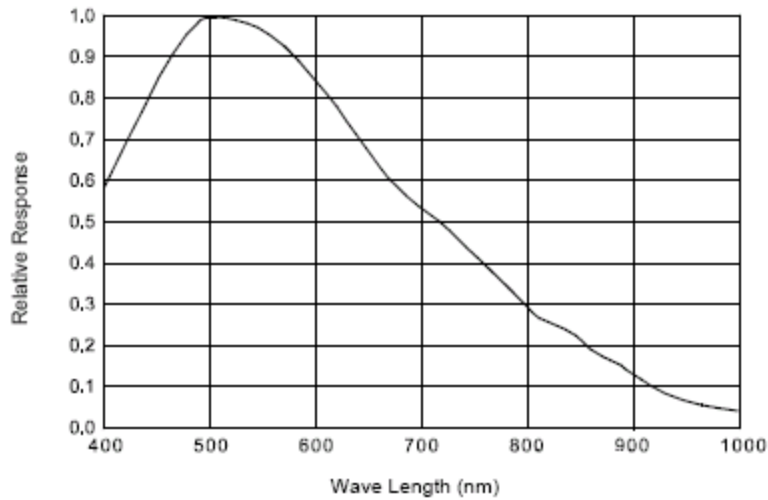

M210 Spectral Response (excludes lens and light source characteristics)

<b>M210 Specifications</b>	
Part Number	601-0360; 601-0360-RA; 601-0387; 601-0387-RA
Pick-up Device	Progressive Scan CCD - 782 (H) x 582 (V) pixels
Sensor Size	1/2" (8 mm) diag - 6.49mm (H) x 4.83mm (V)
Capture Rate	55 full-resolution fps; higher with partial scan
Pixel Size	8.3 x 8.3 micrometers
Gain	100% to 1023%
Shutter Open	26 to 1,000,000 microseconds
Exposure Start Delay	33.44 μsec
Power	24 VDC provided by camera cable (3 Watts)

## M230 line

This camera line captures a 1034 by 779 pixel size image with square pixels. It can partially scan the image horizontally and vertically.

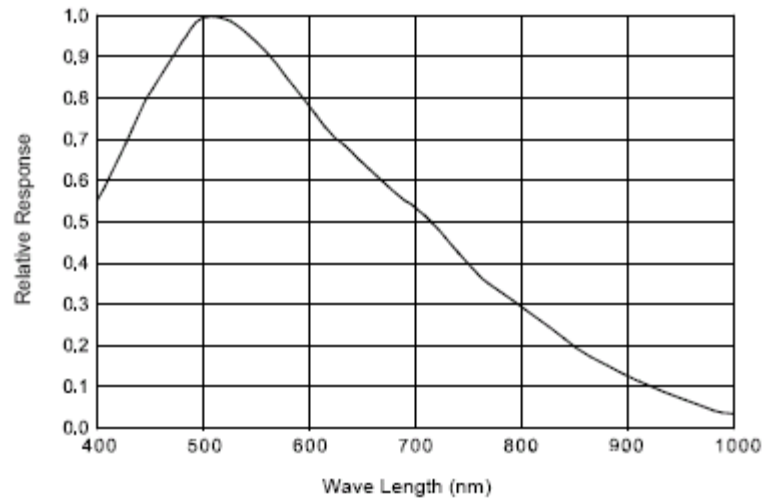

M230 Spectral Response (excludes lens and light source characteristics)

<b>M230 Specifications</b>	
Part Number	601-0361; 601-0361-RA; 601-0388; 601-0388-RA
Pick-up Device	Progressive Scan CCD - 1034 (H) x 779 (V) pixels
Sensor Size	1/3" (6 mm) diag - 4.76mm (H) x 3.57mm (V)
Capture Rate	31 full-resolution fps; higher with partial scan
Pixel Size	4.65 x 4.65 micrometers
Gain	360% to 1023%
Shutter Open	32 to 1,000,000 microseconds
Exposure Start Delay	43.87 $\mu$ sec
Power	24 VDC provided by camera cable (3 Watts)

## M250 line

This camera line captures a 1296 by 966 pixel size image with square pixels. It can partially scan the image horizontally and vertically.

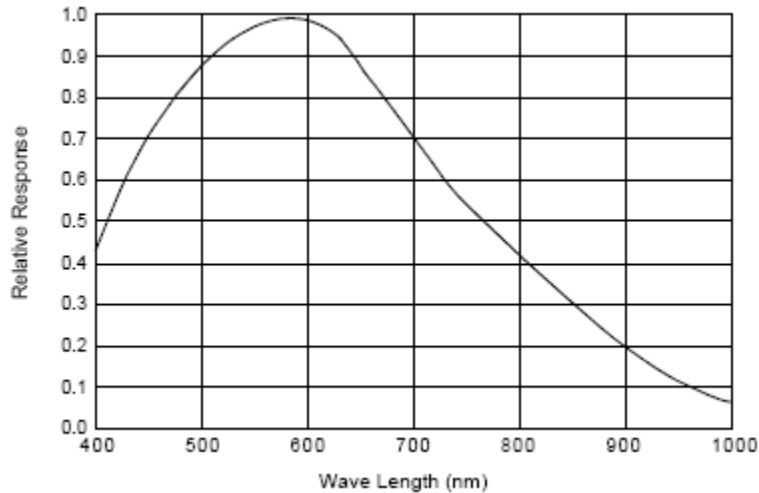

M250 Spectral Response (excludes lens and light source characteristics)

<b>M250 Specifications</b>	
Part Number	601-0362; 601-0362-RA; 601-0389; 601-0389-RA
Pick-up Device	Progressive Scan CCD - 1296 (H) x 966 (V) pixels
Sensor Size	1/3" (6 mm) diag - 4.80mm (H) x 3.60mm (V)
Capture Rate	32 full-resolution fps; higher with partial scan
Pixel Size	3.75 x 3.75 micrometers
Gain	100% to 850%
Shutter Open	22 to 1,000,000 microseconds
Exposure Start Delay	33.12 $\mu$ sec
Power	24 VDC provided by camera cable (3.5 Watts)

## M270 line

This camera line captures a 1392 by 1040 pixel size image with square pixels. It can partially scan the image horizontally and vertically.

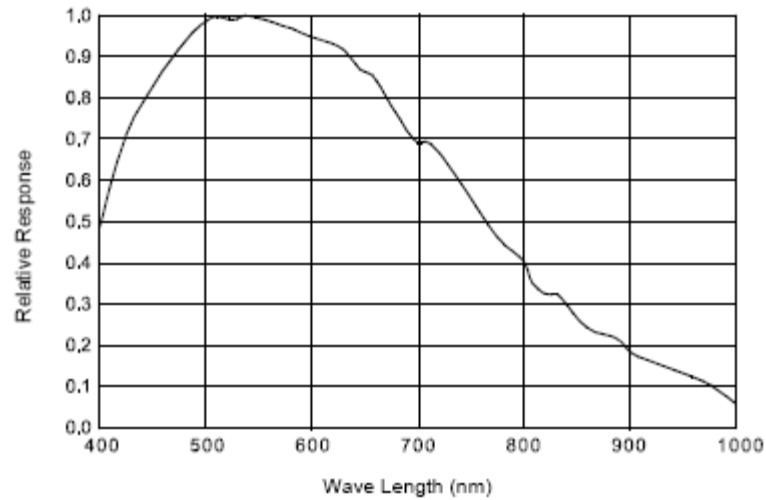

M270 Spectral Response (excludes lens and light source characteristics)

<b>M270 Specifications</b>	
Part Number	601-0363; 601-0363-RA; 601-0390; 601-0390-RA
Pick-up Device	Progressive Scan CCD - 1392 (H) x 1040 (V) pixels
Sensor Size	2/3"(11 mm) diag - 8.77mm (H) x 6.60mm (V)
Capture Rate	17 full-resolution fps; higher with partial scan
Pixel Size	6.45 x 6.45 micrometers
Gain	100% to 1023%
Shutter Open	28 to 1,000,000 microseconds
Exposure Start Delay	58.08 $\mu$ sec
Power	24 VDC provided by camera cable (3.5 Watts)



## M290 line

This camera line captures a 1628 by 1236 pixel size image with square pixels. It can partially scan the image horizontally and vertically.

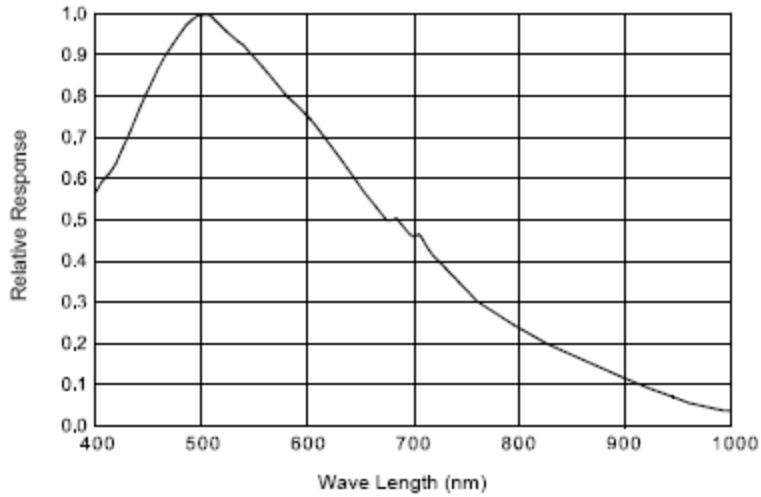

M290 Spectral Response (excludes lens and light source characteristics)

<b>M290 Specifications</b>	
Part Number	601-0353; 601-0353-RA; 601-0380; 601-0380-RA
Pick-up Device	Progressive Scan CCD - 1628 (H) x 1236 (V) pixels
Sensor Size	1/1.8" (8.923 mm) diag - 7.04mm (H) x 5.28mm (V)
Capture Rate	14 full-resolution fps; higher with partial scan
Pixel Size	4.4 x 4.4 micrometers
Gain	100% to 1023%
Shutter Open	31 to 1,000,000 microseconds
Exposure Start Delay	58.92 $\mu$ sec
Power	24 VDC provided by camera cable (3.4 Watts)

## M295 line

This camera line captures a 1628 by 1236 pixel size image with square pixels. It can partially scan the image horizontally and vertically.

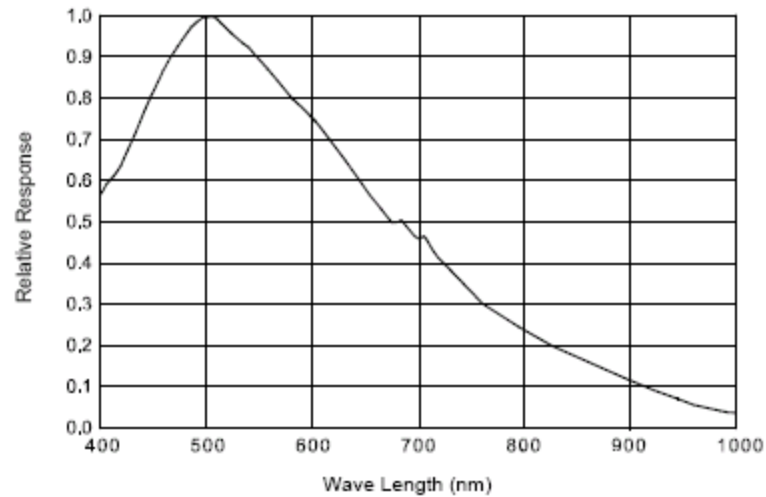

M295 Spectral Response (excludes lens and light source characteristics)

<b>M295 Specifications</b>	
Part Number	601-0420; 601-0420-RA; 601-0421; 601-0421-RA
Pick-up Device	Progressive Scan CCD - 1628 (H) x 1236 (V) pixels
Sensor Size	1/1.8" (8.923 mm) diag - 7.04mm (H) x 5.28mm (V)
Capture Rate	28 full-resolution fps; higher with partial scan
Pixel Size	4.4 x 4.4 micrometers
Gain	100% to 1023%
Shutter Open	31 to 1,000,000 microseconds
Exposure Start Delay	58.92 μsec
Power	24 VDC provided by camera cable (4.3 Watts)

## M3xx, M3xx-RA, M3xxC, M3xxC-RA

All M3xx, M3xx-RA, M3xxC, and M3xxC-RA cameras have the following specifications. Model numbers that include a “C” are color cameras. Model numbers that end in “-RA” are right-angle mount cameras.

M3xx Common Specifications	
Lens Mount	C mount
Cabling	Camera cable provides power and trigger. Ethernet cable transmits video
Operating Environment	Temperature: 0 to +50 C (+32 to 122 F) Humidity: 0 to 90% (non-condensed)
Vibration	5g (11 to 200 Hz)
Power	24 VDC provided by camera cable (3 Watts)
Weight	7.7 ounces (~220 grams)
Software Version	Impact Software V10.0 or greater

## M300 line

This camera line captures a 648 by 488 pixel size image with square pixels. It can partially scan the image horizontally and vertically.

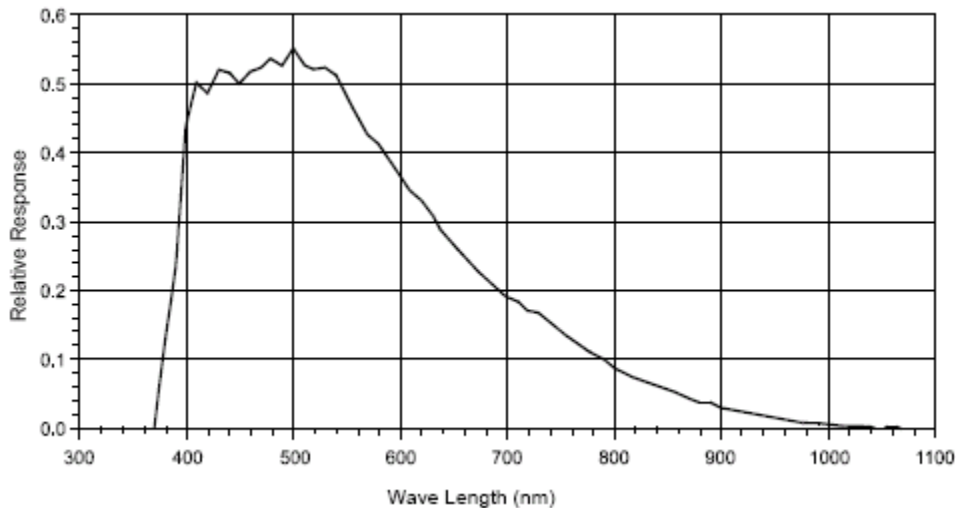

M300 Spectral Response (excludes lens and light source characteristics)

M300 Specifications	
Part Number	601-0354, 601-0354-RA, 601-0381, 601-0381-RA
Pick-up Device	Progressive Scan CCD - 648 (H) x 488 (V) pixels
Sensor Size	1/3" (5.92 mm) diag - 4.736mm (H) x 3.552mm (V)
Capture Rate	210 full-resolution fps; higher with partial scan
Pixel Size	7.4 x 7.4 micrometers
Gain	100% to 500%

<b>M300 Specifications</b>	
Shutter Open	28 to 1,000,000 microseconds
Exposure Start Delay	23.64 $\mu$ sec

## M330 line

This camera captures a 1004 by 1004 pixel size image with square pixels. It can partially scan the image horizontally and vertically.

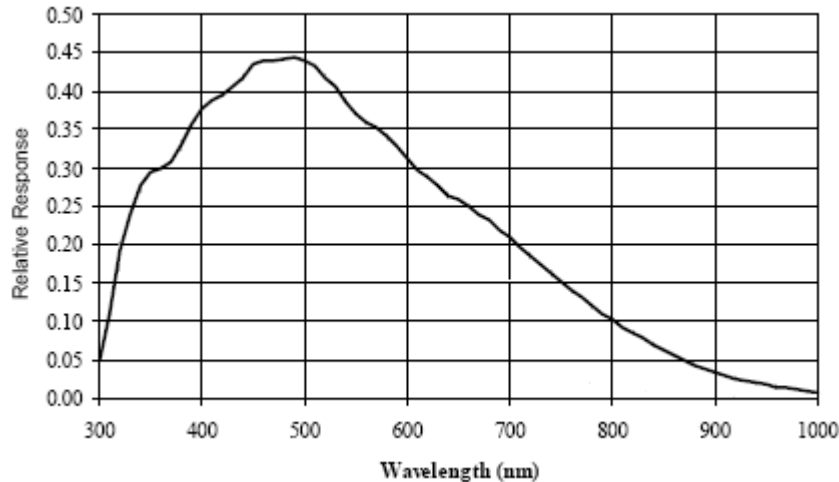

M330 Spectral Response (excludes lens and light source characteristics)

<b>M330 Specifications</b>	
Part Number	601-0364, 601-0364-RA, 601-0391, 601-0391-RA
Pick-up Device	Progressive Scan CCD - 1004 (H) x 1004 (V) pixels
Sensor Size	2/3" (10.5 mm) diag - 7.4 mm (H) x 7.4 mm (V)
Capture Rate	60 full-resolution fps; higher with partial scan
Pixel Size	7.4 x 7.4 micrometers
Gain	100% to 500%
Shutter Open	28 to 1,000,000 microseconds
Exposure Start Delay	23.64 $\mu$ sec

# M350 line

This camera line captures a 1608 by 1208 pixel size image with square pixels. It can partially scan the image horizontally and vertically.

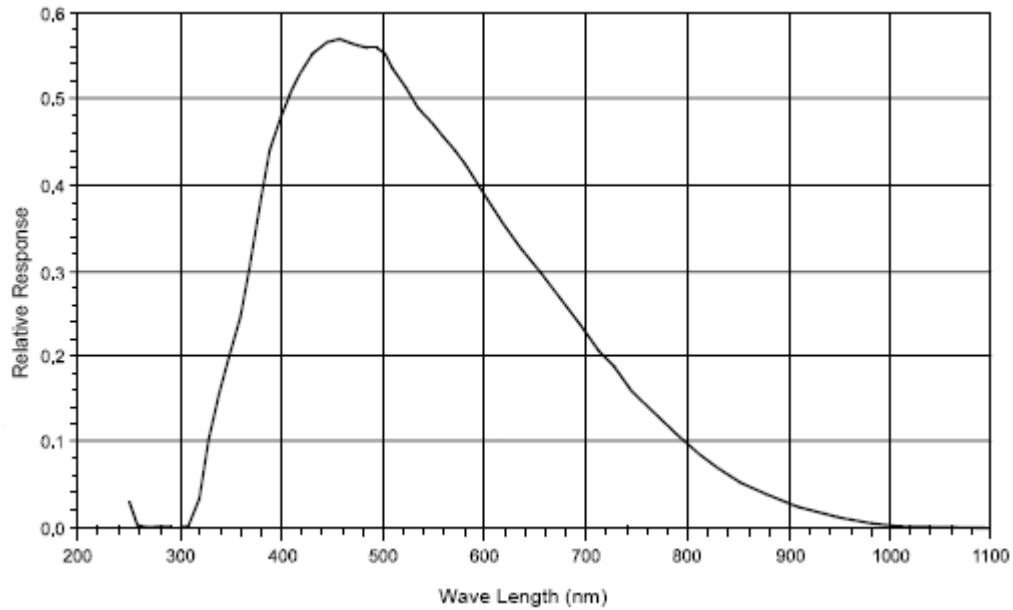

M350 Spectral Response (excludes lens and light source characteristics)

<b>M350 Specifications</b>	
Part Number	601-0365, 601-0365-RA, 601-0392, 601-0392-RA
Pick-up Device	Progressive Scan CCD - 1608 (H) x 1208 (V) pixels
Sensor Size	1" (14.8 mm) diag - 11.84 mm (H) x 8.88 mm (V)
Capture Rate	35 full-resolution fps; higher with partial scan
Pixel Size	7.4 x 7.4 micrometers
Gain	100% to 500%
Shutter Open	50 to 1,000,000 microseconds
Exposure Start Delay	65.98 $\mu$ sec

## M390 line

This camera line captures a 2456 by 2058 pixel size image with square pixels. It can partially scan the image horizontally and vertically.

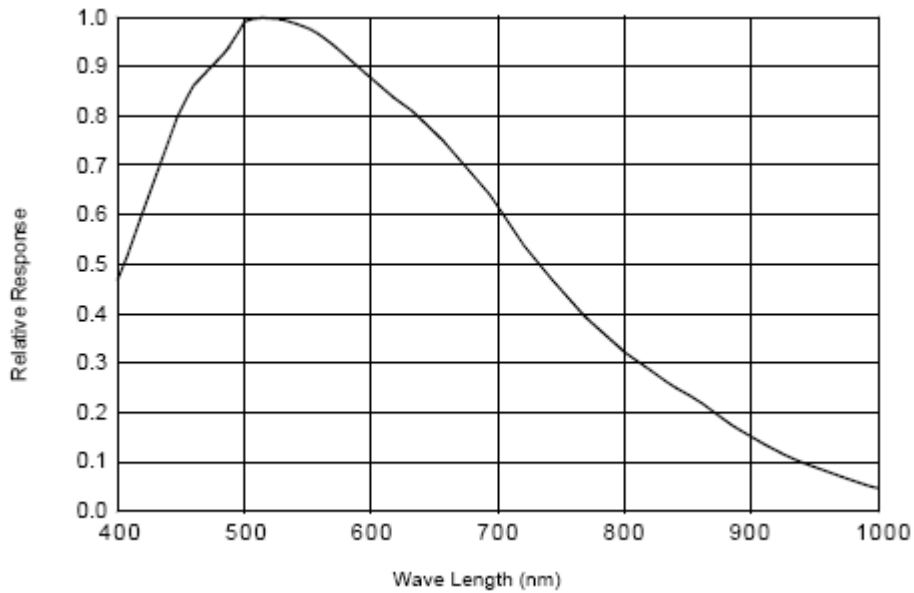

M390 Spectral Response (excludes lens and light source characteristics)

<b>M390 Specifications</b>	
Part Number	601-0355, 601-0355-RA, 601-0382, 601-0382-RA
Pick-up Device	Progressive Scan CCD - 2456 (H) x 2058 (V) pixels
Sensor Size	2/3" (11.016 mm) diag - 8.44mm (H) x 7.07mm (V)
Capture Rate	17 full-resolution fps; higher with partial scan
Pixel Size	3.45 x 3.45 micrometers
Gain	0% to 500%
Shutter Open	29 to 1,000,000 microseconds
Exposure Start Delay	32.06 $\mu$ sec

# M5xx

M5xx cameras are monochrome, GigE line scan cameras. They all have the following specifications.

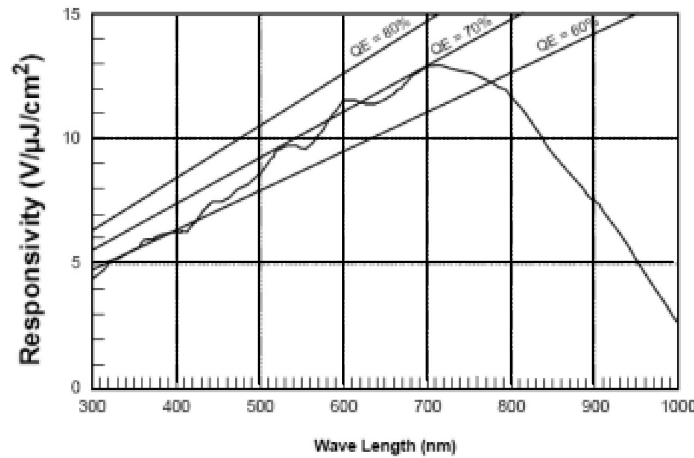

M5xx Spectral Response (excludes lens and light source characteristics)

M5xx Common Specifications	
Lens Mount	F or C mount ; Add -F to part number for F mount
Cabling	6-pin cable provides power. 12-pin cable provides frame and line triggers. Ethernet cable transmits video
Operating Environment	Temperature: 0 to +50 C (+32 to 122 F) Humidity: 20 to 80% (non-condensed)
Weight	~8.2 ounces (235 grams); ~12.1 ounces (345 grams) with lens adapter
Software Version	Impact Software V10.1.0 or greater

# M510

This camera captures a 1024 pixel width image with 18,700 lines per second maximum line rate.

M510 Specifications	
Part Number	601-0393
Pick-up Device	Linear CCD
Sensor Size	1024 pixels
Capture Rate	18,700 lines per second maximum
Pixel Size	10 x 10 micrometers
Power	12 VDC provided by 6-pin camera cable (6 Watts maximum)

## M520

This camera captures a 1024 pixel width image with 35,700 lines per second maximum line rate.

<b>M520 Specifications</b>	
Part Number	601-0394
Pick-up Device	Linear CCD
Sensor Size	1024 pixels
Capture Rate	35,700 lines per second maximum
Pixel Size	10 x 10 micrometers
Power	12 VDC provided by 6-pin camera cable (7 Watts maximum)

## M530

This camera captures a 1024 pixel width image with 56,100 lines per second maximum line rate.

<b>M530 Specifications</b>	
Part Number	601-0395
Pick-up Device	Linear CCD
Sensor Size	1024 pixels
Capture Rate	56,100 lines per second maximum
Pixel Size	10 x 10 micrometers
Power	12 VDC provided by 6-pin camera cable (8 Watts maximum)

## M540

This camera captures a 2048 pixel width image with 9,500 lines per second maximum line rate.

<b>M540 Specifications</b>	
Part Number	601-0396
Pick-up Device	Linear CCD
Sensor Size	2048 pixels
Capture Rate	9,500 lines per second maximum
Pixel Size	10 x 10 micrometers
Power	12 VDC provided by 6-pin camera cable (6.5 Watts maximum)



## M550

This camera captures a 2048 pixel width image with 18,700 lines per second maximum line rate.

<b>M550 Specifications</b>	
Part Number	601-0397
Pick-up Device	Linear CCD
Sensor Size	2048 pixels
Capture Rate	18,700 lines per second maximum
Pixel Size	10 x 10 micrometers
Power	12 VDC provided by 6-pin camera cable (7.5 Watts maximum)

## M560

This camera captures a 2048 pixel width image with 29,200 lines per second maximum line rate.

<b>M560 Specifications</b>	
Part Number	601-0398
Pick-up Device	Linear CCD
Sensor Size	2048 pixels
Capture Rate	29,200 lines per second maximum
Pixel Size	10 x 10 micrometers
Power	12 VDC provided by 6-pin camera cable (8.5 Watts maximum)



# Processor I/O Reference

This section discusses the M-Series Processor I/O scheme. Refer to this section for all specifications when wiring your inputs and outputs into the Processor.

**Note:** Your M-Series Processor does not provide a voltage source for inputs and outputs – it must be provided by an external source. Refer to the module tables below for more voltage requirement information.

**Note:** The Trigger Signal and Strobe Output for M-Series cameras are separate and not part of the M-Series Processor inputs and outputs. See M-Series Cameras on page 3-1 for details.

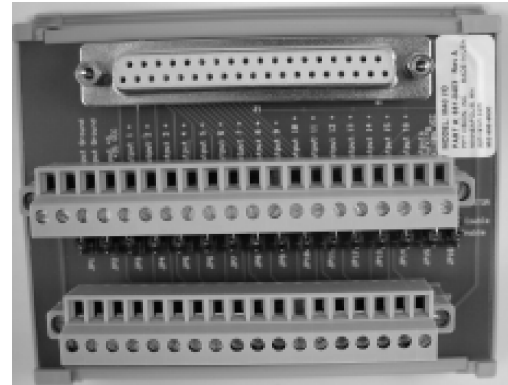

## Processor I/O Connection

To connect M-Series processor input and output signals use cable 606-0675-xx (37 pin D-sub Male to Male Cable) with terminal block 661-0403. (For other terminal blocks, see “Processor Input/Output (Older Terminal Blocks)” on page 6-24.)

Terminal Name	Signal	Notes
Input Cmn (2)	Input Common	
Input 1 through Input 16	Input 1+ through Input 16+	See Input table on page 4-2
Output Ground (2)	Output Ground	
Output +5 to +35 VCC	Output Control Voltage	See Supply Voltage table on page 4-3
Output 1 through Output 16	Outputs 1 through 16 (sinking or sourcing selectable)	See “Pullup Jumpers to Enable Sourcing” on page 4-3
Outputs Sourcing Pullups VCC	Output Pullup - use if Output needs to be sourcing	+24 VDC (Jumpers JP1 through JP16 enable/disable connection)
JP1 through JP16	Pullup Enable/Disable	See “Pullup Jumpers to Enable Sourcing” on page 4-3

## Processor Inputs

The M-Series Processors contain sixteen general-purpose input connections.

Two inputs serve as both event and polled inputs (Inputs 1 and 2). The remaining inputs are polled. The event inputs are interrupt-driven which means that a change of state on the input will immediately cause an action and any inspection task that uses that input will run. Polled input means that the input’s status is checked based on conditions defined in the inspection task.

Interrupt-driven inputs are edge-triggered and the duration of the input pulse must be longer than the debounce time. The active trigger edge (rising, falling, or both), input pulse duration, and debounce, are all configured in the Vision Program Manager Settings tab.

This table describes the input characteristics.

Input Resistance (nominal)	Input Voltage	Turn On Voltage	Turn Off Voltage	Isolated Voltage
1.2k @ 0.5 W	0-24 Vdc	>3 Vdc	< 0.8 Vdc	2500 Vrms

## Input Wiring

The diagrams below show two ways to wire a sensor to a general purpose or event input.

**Note:** All connections to inputs must be made using properly grounded shielded cable. All inputs must be wired as either sinking or sourcing, they cannot be mixed. There is only one “Input Common” connection for all the inputs.

### General Purpose Input Circuit (Sinking)

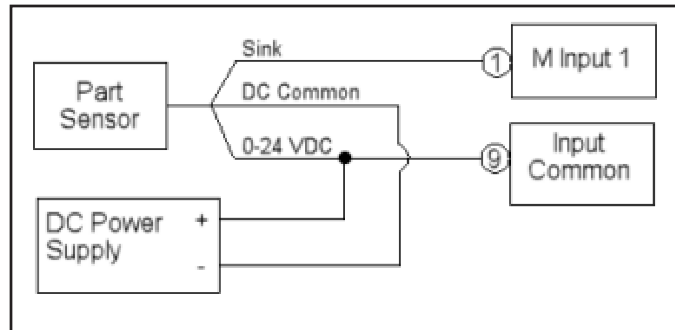
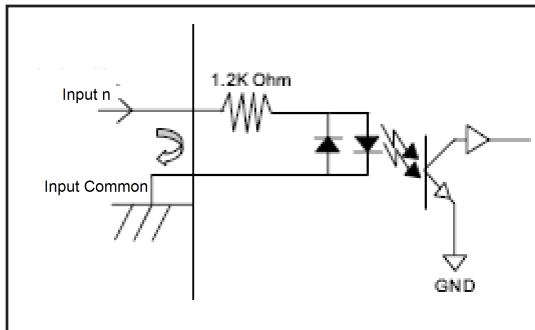

### General Purpose Input Circuit (Sourcing)

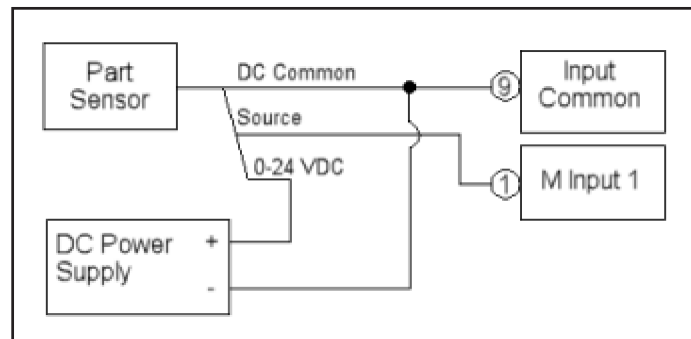
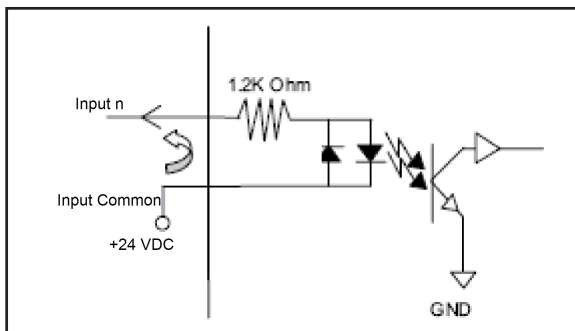

---

## Processor Outputs

The M-Series Processors contain sixteen general-purpose output connections.

The table below describes the output's electrical characteristics.

<b>Supply Voltage</b>	+5 VDC (minimum) to +35 VDC (maximum)
<b>Sink Current (maximum)</b>	1 Amp per output
<b>Source Current (maximum)</b>	15 Milliamperes per output (see "Pullup Jumpers" below)

---

**Note:** An external power source is required to power an output load. The outputs are merely switches that are open or closed. All output connections must use properly grounded and shielded cable.

**Note:** The Trigger Signal and Strobe Output for M-Series cameras are separate and not part of the M-Series Processor inputs and outputs. See M-Series Cameras on page 3-1 for details.

---

## Pullup Jumpers to Enable Sourcing

Jumpers JP1 through JP16 enable and disable the connection between their respective Output and the "Outputs Sourcing Pullups VCC" signal on the terminal block. If a jumper is in the Enable position, the Sourcing VCC is connected to the Output and it provides a sourcing signal (it is normally low and goes high when On). If a jumper is in the Disable position, the Output provides a sinking signal (normally high and goes low when On). The Discrete Output tool in the vision program must be programmed to provide the desired output level. Refer to Discrete Output tool in the Impact Reference Guide (843-0093).

---

**Note:** With the sourcing pullup jumper enabled, the maximum current per output is 15 Milliamperes.

---

# Output Wiring

The diagrams below show internal circuit diagrams and how to wire processor outputs.

## General Purpose Output Circuit (Sinking)

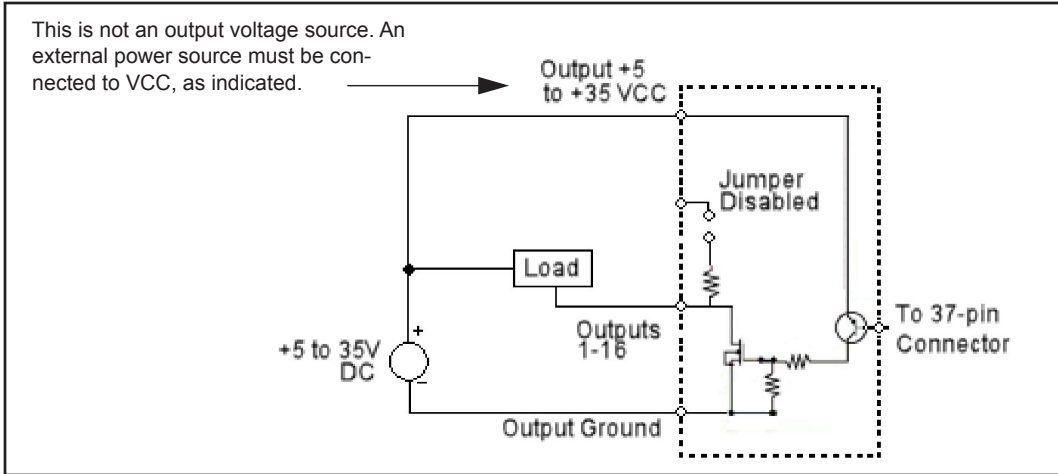

**NOTES:** To prevent output damage, all inductive loads must have noise suppressors connected directly across the load, as close to the load as possible.  
The Output +5 to +35 VCC terminal is not an output voltage source. An external power source must be connected to it.

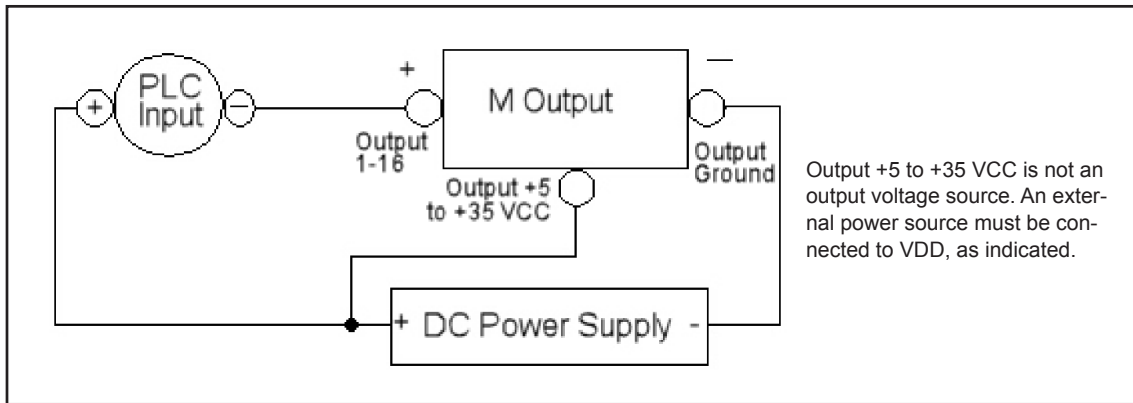

### General Purpose Output Circuit (Sourcing)

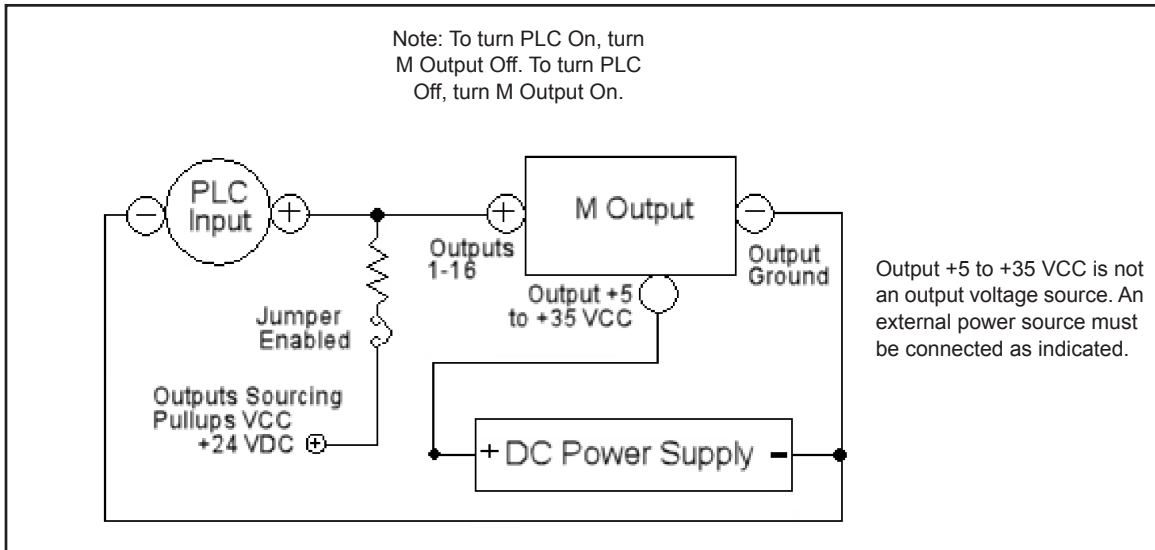
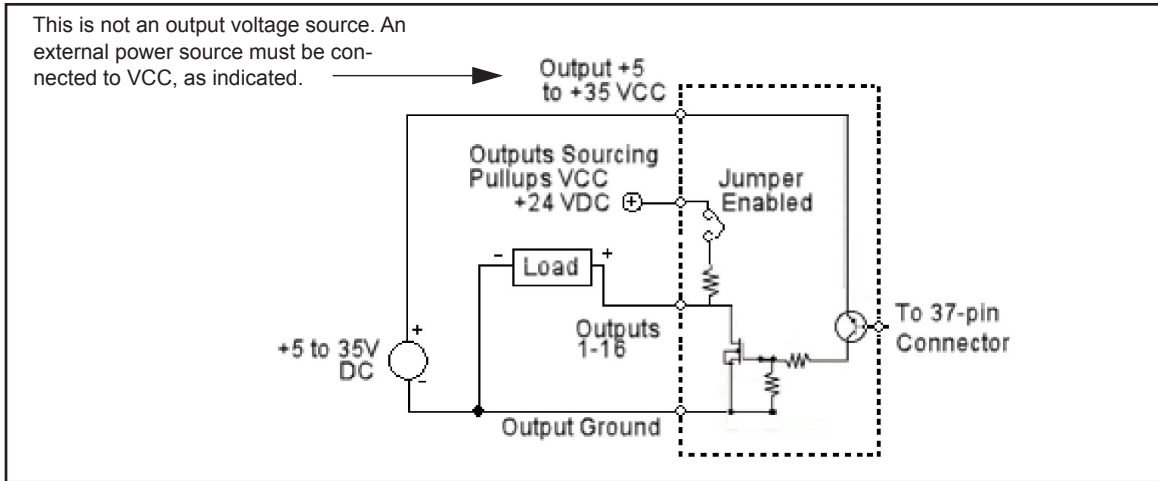





# Cable Reference

This chapter documents M-Series Processor and Camera cable assemblies.

---

## Cables

The following cables connect different hardware devices to the Processor.

### Processor Ethernet

An Ethernet cable (Part number 606-0457-xx) is used to connect the M-Series Processor to the camera and between the Processor and any external network. The last two digits of the part number indicate the cable length in feet. We recommend you use shielded Cat5e Ethernet cable or better to connect the camera and the Processor.

A crossover cable is not required because the Ethernet ports are auto-negotiating; that is they can tell the difference between a peer-to-peer connection and a router/switch connection and they configure themselves and the communications to suit the environment.

---

**NOTE:** We recommend that you do not use a switch or a router between the M-Series Processor and the camera.

---

### Processor Input/Output

The terminal block and cable for connecting M-Series processor are listed in the table below. For connection diagrams, see “Processor I/O Connection” on page 4-1. The last two digits of the part number indicate the cable length in meters.

Connector Type	Part Number
Terminal Block - 37 pin D-sub to Screw Terminal	661-0403
I/O Cable - 37 pin D-sub Male to Male Cable (for use with above terminal block)	606-0675-xx

### Processor Power Supply Connector

---

This equipment is to be powered by a Listed power supply for the U.S. and Canada, or a power supply that meets the requirements for use where either IEC 60950 or EN60950 is applicable.

---

See “MX20 and MX40 Processor Power Supply Connection” on page 2-9 or “MX80 Processor Power Supply Connection” on page 2-10 for more details on wiring the power supply cable.

## MX20 and MX40 Processor Serial Port

A standard serial cable is used to connect the MX20 and MX40 Processors to the serial port on an external device (e.g. terminal, PLC, motion controller, data recorder). This may require using a null modem cable or adapter. The serial port does not support hardware (CTS/RTS) or software (Xon/Xoff) data flow control. The M-Series Processor supports RS-232 communication protocol only. RS-485 is not supported.

Pin Number	Signal Name
1	Carrier Detect (CD)
2	Received Data (RXD)
3	Transmitted Data (TXD)
4	Data Terminal Ready (DTR)
5	Signal Ground (GND)
6	Data Set Ready (DSR)
7	Request To Send (RTS)
8	Clear To Send (CTS)
9	Ring Indicator (RI)



**9 Pin Male**  
(Pin Side)

## MX80 Processor Serial Ports

The MX80 processor provides four serial port connections. The connector on the front panel is Serial Port 1 (COM 5). CAM 1 controls this serial port. Use a standard serial cable to connect this serial port to an external device (e.g. terminal, PLC, motion controller, data recorder).

The connector on the rear panel provides three serial port connections for Serial Ports 2, 3, and 4 (COM 2, 3, and 4 respectively). CAM 2 controls Serial Port 2, CAM 3 controls Serial Port 3, and CAM 4 controls Serial Port 4. Use the provided cable to connect the rear connector to serial ports on an external device. This cable has a DB-62P connector on one end and three standard serial port connectors (DB9) on the other end. The connector wiring pin numbers on these three connectors are the same as the MX20 and MX40 (see “MX20 and MX40 Processor Serial Port” on page 5-2).

Connecting any of these serial ports may require using a null modem cable or adapter. The serial ports do not support hardware (CTS/RTS) or software (Xon/Xoff) data flow control. They support RS-232 communication protocol only. RS-485 is not supported.

## MX40 VGA Connector

The MX40 processor requires a monitor and keyboard when it first starts, and to configure the system. The VGA cable can be a maximum of 10 meters long.

## MX80 DVI-I Video Connector

The MX80 processor requires a monitor and keyboard when it first starts, and to configure the system. A VGA cable with the appropriate adapter can be used on this connector (10 meters maximum).

## M1xx Camera

The terminal block and cable for connecting M-Series M1xx cameras are listed in the table below. For cable wire color codes and connection diagrams, see “M1xx Camera Connection” on page 3-8. The last two digits of the part number indicate the cable length in meters.

Connector Type	Part Number
Terminal Block	661-0399
Camera Cable - DB9 to 6-pin Hirose Male (for use with above terminal block)	606-0674-xx

## M2xx and M3xx Cameras

The terminal block and cable for connecting M-Series M2xx and M3xx cameras are listed in the table below. For cable wire color codes and connection diagrams, see “M2xx and M3xx Camera Connection” on page 3-12. The last two digits of the part number indicate the cable length in meters.

Connector Type	Part Number
Terminal Block	661-0400
Camera Cable - HD-15 to 12-pin Hirose Male (for use with above terminal block)	606-0673-xx

## M5xx Camera

The terminal block and cable for connecting M-Series M5xx cameras are listed in the table below. For cable wire color codes and connection diagrams, see “M5xx Camera Connection” on page 3-16.

---

NOTE: Do NOT use the M2xx/M3xx terminal block (661-0400) to connect this camera. It will not provide the correct signal levels.

---

The last two digits of the part number indicate the cable length in meters.

Connector Type	Part Number
Terminal Block	661-0401
I/O Cable - HD-15 to 12-pin Hirose Male (for use with above terminal block)	606-0673-xx
Power Cable - DB9 to 6 pin Hirose Male (for use with above terminal block)	606-0674-xx



# Appendix

## Using Older Terminal Blocks

**IMPORTANT:** This section describes how to connect M-Series cameras using the older, discrete style of terminal block. To use the newer, integrated style of terminal block, see “Connecting the Camera” on page 3-8.

**WARNING:** Never wire M1xx Camera Strobe Outputs in parallel with M1xx, M2xx, or M3xx Camera Strobe Outputs. This will damage the cameras.

### M1xx Camera Connection (Older Terminal Blocks)

Camera power, trigger signals, and strobe triggers can be connected to the camera using one of two methods: a terminal block and cable or an unterminated cable only. To use a terminal block (248-0140) you must also use the optional Hirose 6-pin to DB9 camera cable (606-0674-xx).

To connect the camera using an unterminated cable, use the optional Hirose 6-pin to unterminated cable (part number 606-0672-xx).



Terminal	Color	Signal Name	Notes
1	Blue	Camera Power VCC	Do NOT apply power to this terminal if using Power Over Ethernet (PoE) +12 VDC (+-10%) @ 250 mA Max Maximum: +13.2 VDC Minimum: +11.3 VDC
2	Orange	Camera Trigger In	0 to +24 VDC recommended Off: 0 to +1.4 VDC On: +2.2 to +24 VDC; 5 to 15 ma Maximum +30 VDC
3	Green	No Connection	
4*	Wht/ Grn	Strobe Trigger Out	DO NOT APPLY ANY VOLTAGE DIRECTLY TO THIS OUTPUT. DO NOT WIRE OUTPUTS IN PARALLEL.
5	Wht/ Org	I/O Ground	
6	Wht/ Blu	Camera Power Ground	
7*	None	Strobe VCC	Based on Strobe requirement Max: +30 VDC; 50 ma (*Block contains 1k Ohm 2W resistor between terminals 4 and 7)

**NOTE:** The M1xx camera's Strobe Trigger Out is normally closed (it opens to trigger the strobe). Do not wire multiple cameras' strobe outputs in parallel to trigger a single strobe.

To connect the power cable to the camera, align the cable connector with the connector on the rear of the camera, push gently until the cable connector seats securely, then tighten the connector collar. To disconnect it, loosen the collar completely, then grasp the connector and gently pull.

---

**NOTE:** To reduce stress on the cable and connectors, loop the cable and fasten it to the camera's mounting block. Do not crimp or tie the cable tightly with wire ties as this may damage it internally. The cable is not intended for continuous flexing or movement. The cable's maximum bend radius is fifteen times the cable diameter.

---

# M1xx Circuit Diagrams (Older Terminal Blocks)

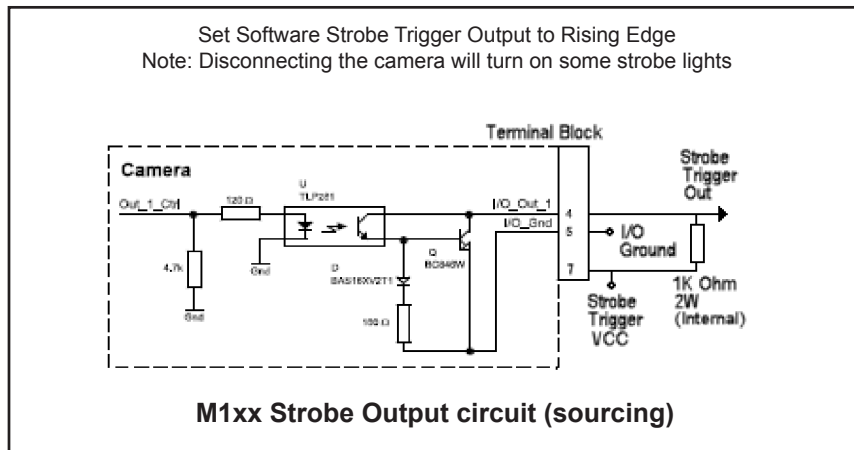
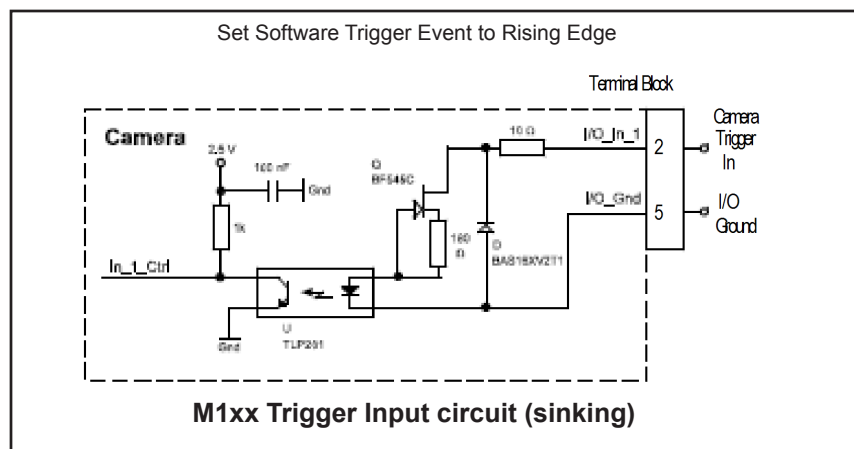
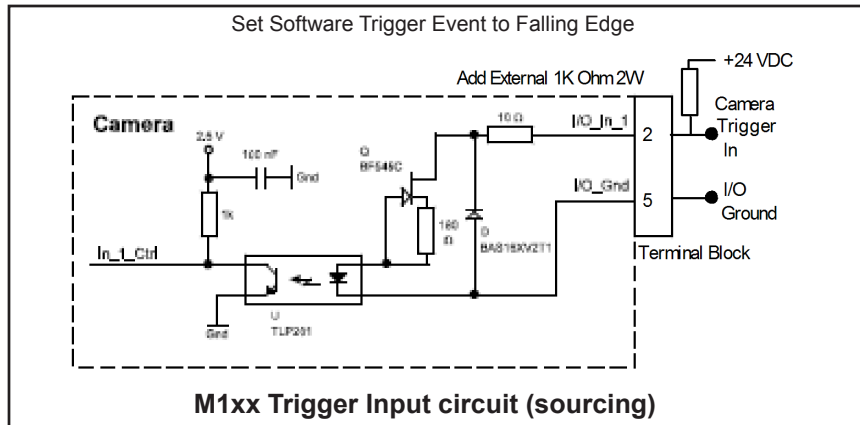

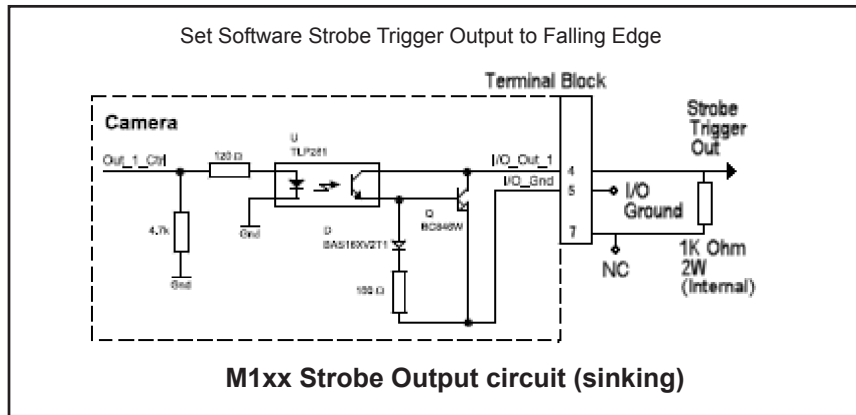

## M1xx Terminal Connections (Older Terminal Blocks)

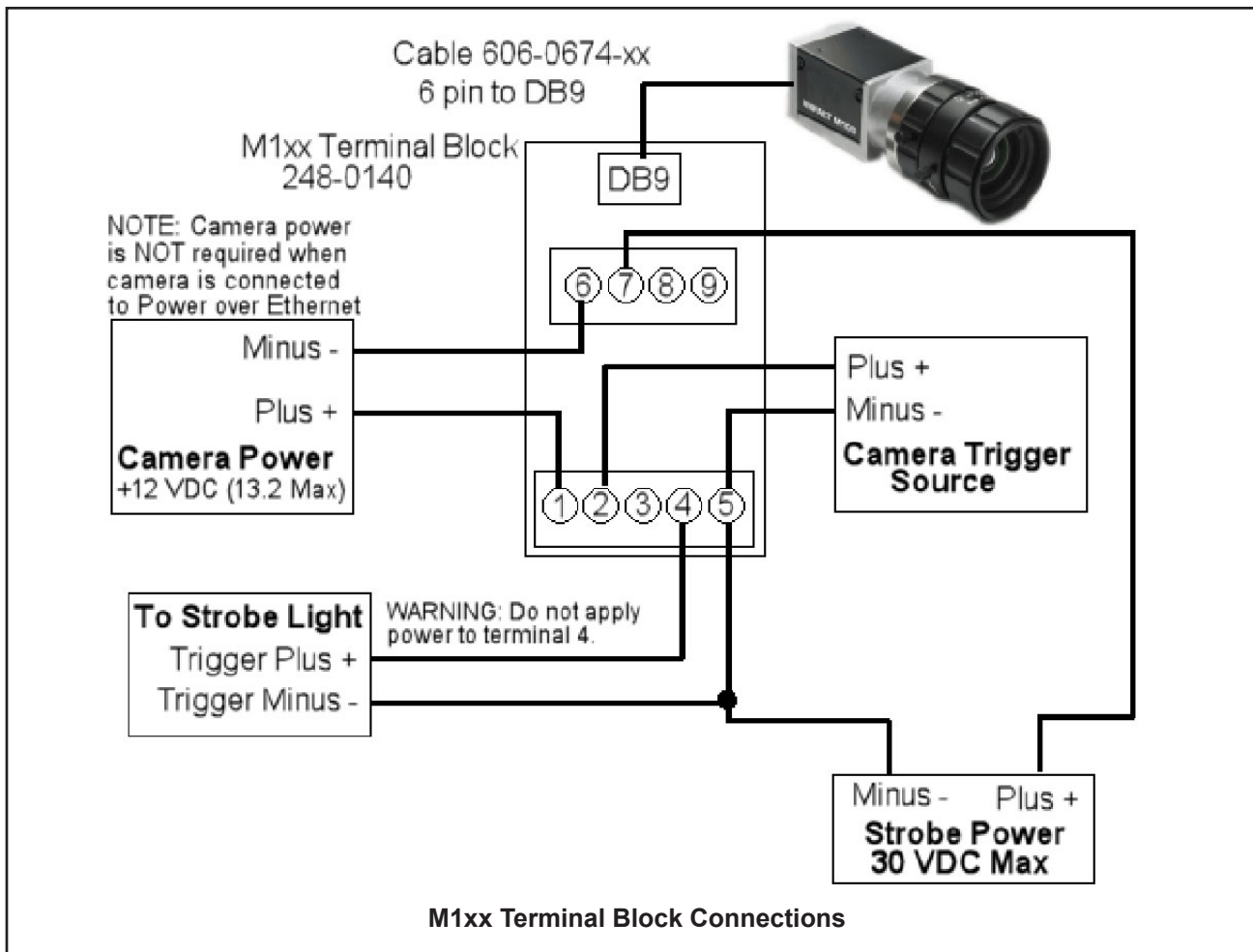



# M1xx Unterminated Cable Connections (Older Terminal Blocks)

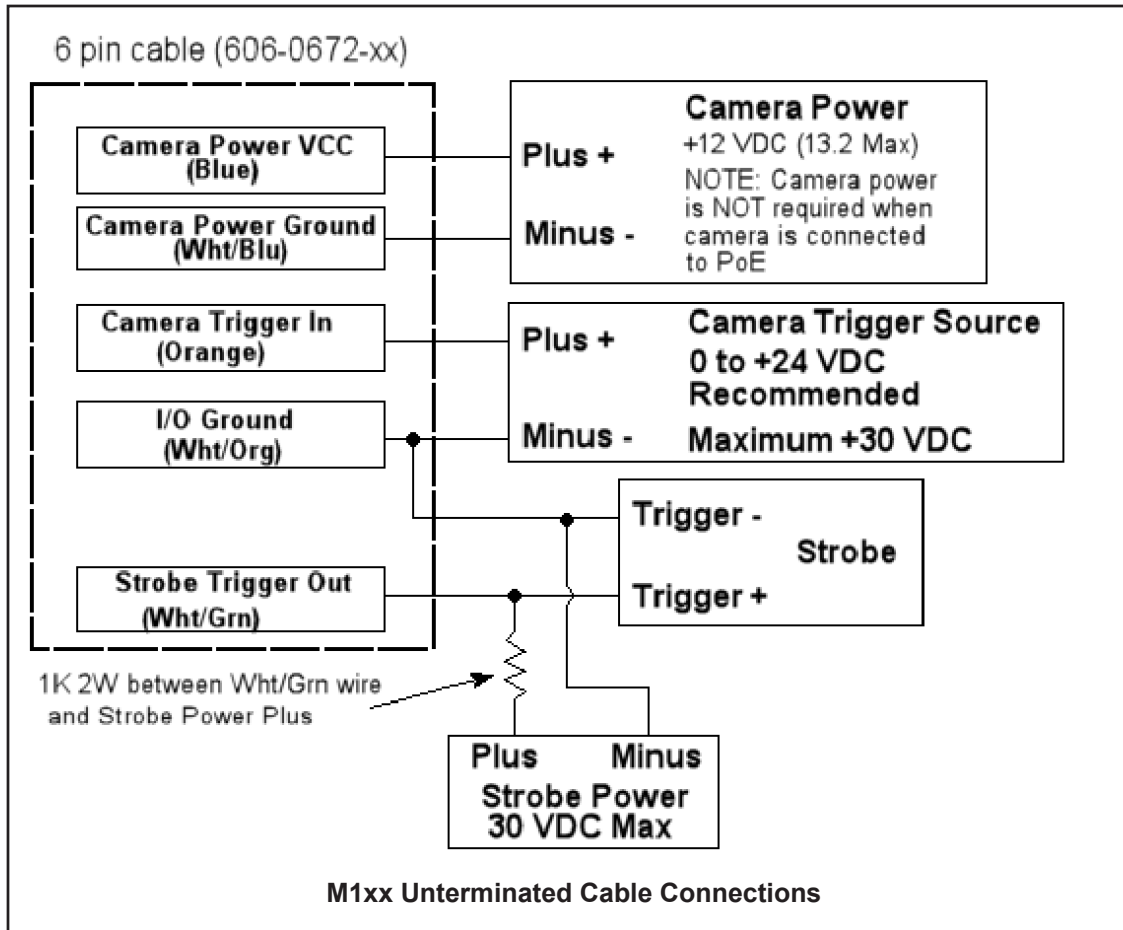

## M2xx and M3xx Camera Connection (Older Terminal Blocks)

Camera power, trigger signal, and strobe trigger can be connected to the camera using one of two methods: a terminal block and cable or an unterminated cable only. To use a terminal block (248-0141), you must also use the optional Hirose 12-pin to HD-15 camera cable (606-0673-xx).

To connect the camera using an unterminated cable, use the optional Hirose 12-pin to unterminated cable (part number 606-0671-xx).

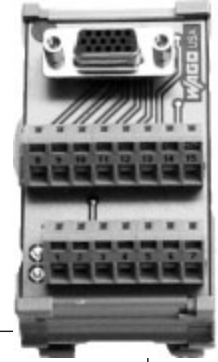

Terminal	Color	Signal Name	Notes
1 2	Wht/Blu Wht/Org	Camera Power Ground Camera Power Ground	See Note 1 below
3	Wht/Brn	Camera Trigger In	0 to +24 VDC recommended Off: 0 to + 1.4 VDC On: +2.2 to + 24 VDC; 5 to 15 mA Maximum: +30 VDC
4	Brn/Wht	DO NOT USE	
5	Wht/Grn	Camera Trigger Ground	
6*	Wht/Gry	Strobe Trigger Out	
7	Gry/Wht	DO NOT USE	
8 9	Blu/Wht Org/Wht	Camera Power VCC Camera Power VCC	+12 to +24 VDC recommended @ 500 mA Max Maximum: +30 VDC See Note 1 below
10	Grn/Wht	Strobe VCC	Based on strobe requirement Maximum: +30 VDC; 100 ma
11	Red/Blu	DO NOT USE	
12	Blu/Red	DO NOT USE	
13*	None	Strobe Output Ground	(*Block contains 270 Ohm 2W resistor between terminals 6 and 13)

**NOTE 1:** Pins 1 and 2 are tied together inside of the camera. Pins 8 and 9 are tied together inside of the camera. To avoid a voltage drop when there are long wires between your power supply and the camera, we recommend that you provide camera power VCC through separate wires between your power supply and pins 8 and 9 on the camera. We also recommend that you provide camera power ground through separate wires between your power supply and pins 1 and 2 on the camera.

To connect the power cable to the camera, align the cable connector with the connector on the rear of the camera, push gently until the cable connector seats securely, then tighten the connector collar. To disconnect it, loosen the collar completely, then grasp the connector and gently pull.

**NOTE:** To reduce stress on the cable and connectors, loop the cable and fasten it to the camera's mounting block. Do not crimp or tie the cable tightly with wire ties as this may damage it internally. The cable is not intended for continuous flexing or movement. The cable's maximum bend radius is fifteen times the cable diameter.

# M2xx and M3xx Circuit Diagrams (Older Terminal Blocks)

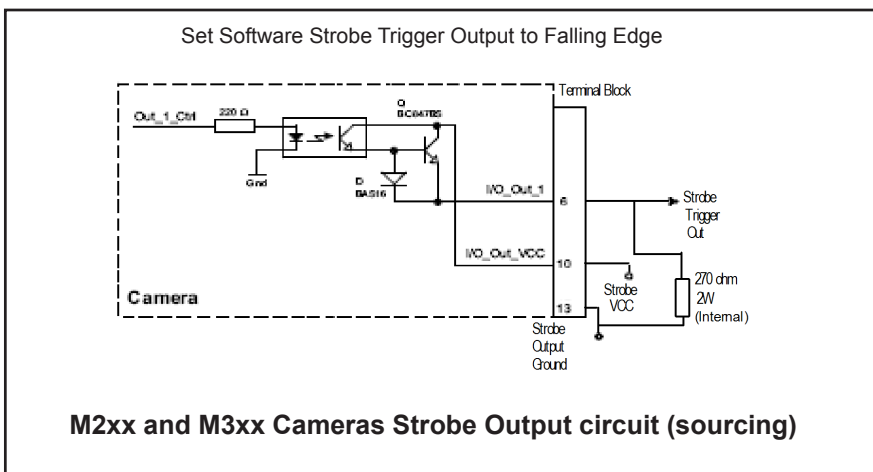
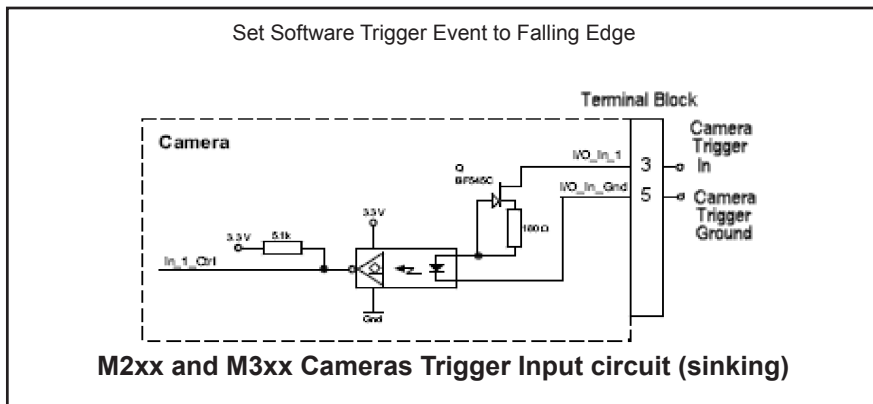
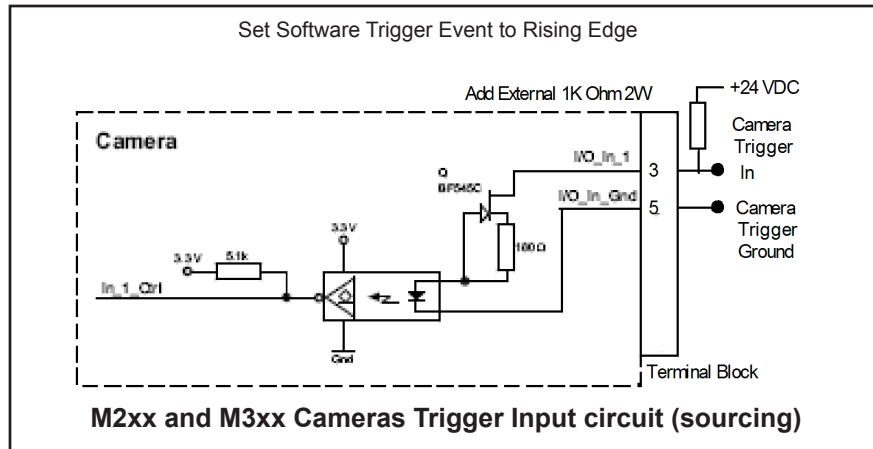

## M2xx and M3xx Terminal Connections (Older Terminal Blocks)

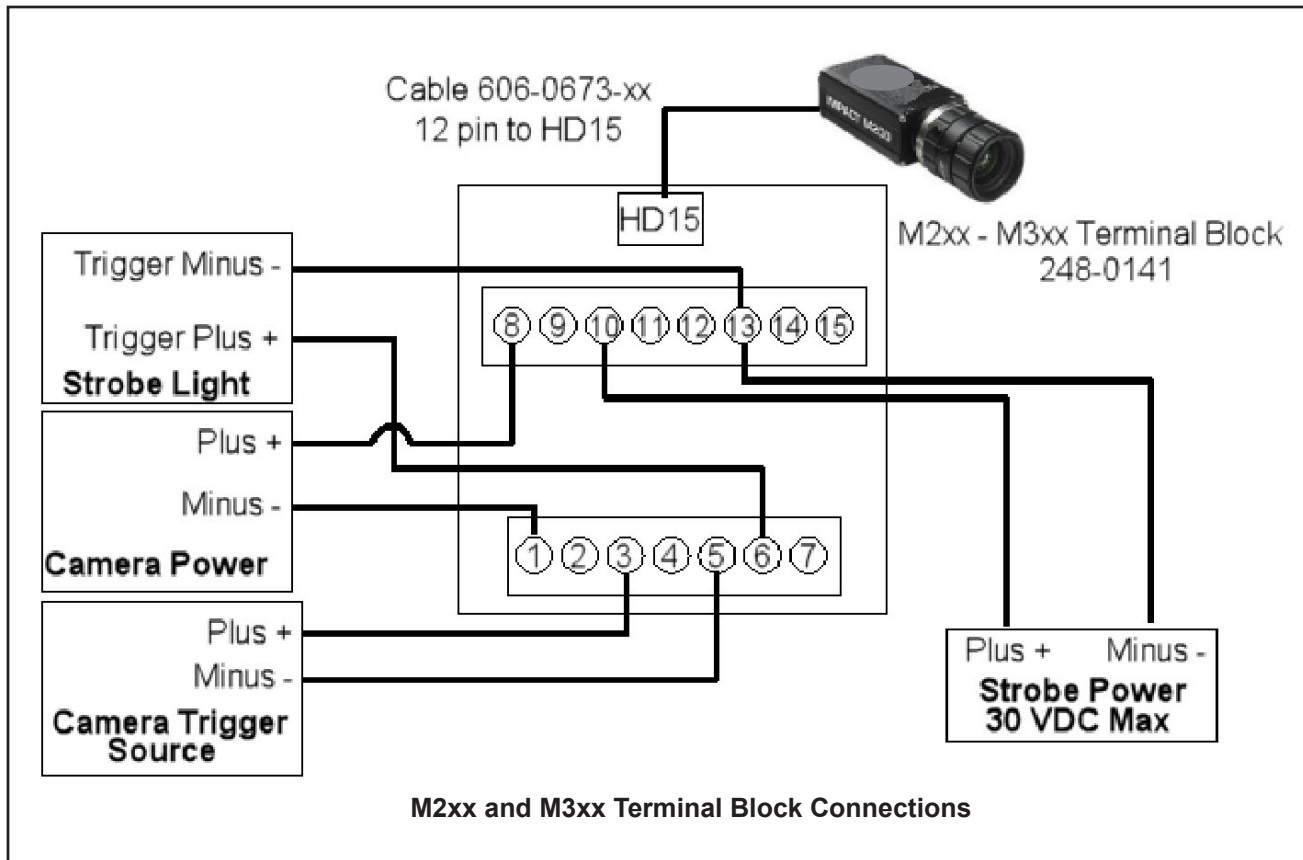

## M2xx and M3xx Unterminated Cable Connections (Older Terminal Blocks)

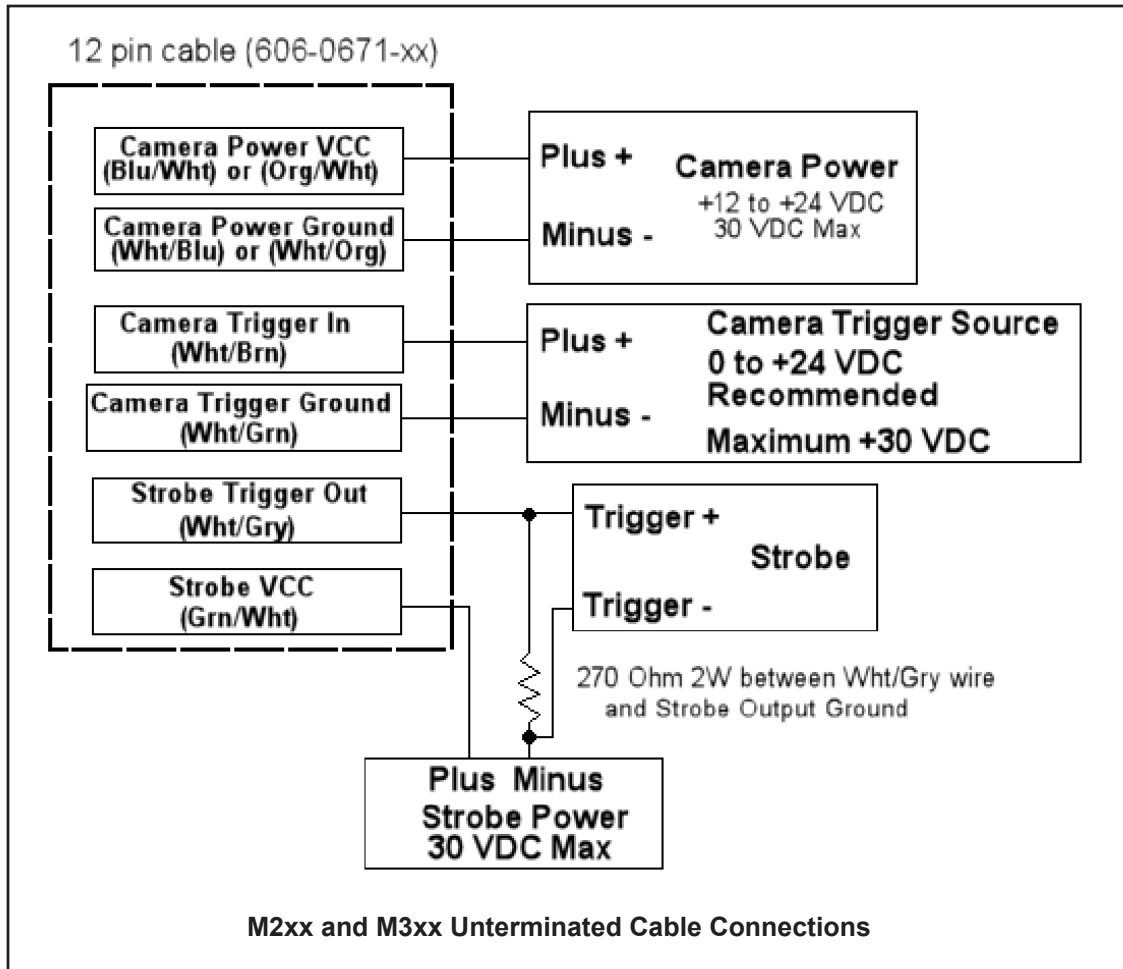

## M5xx Camera Connection (Older Terminal Blocks)

This camera uses three cables, one for Ethernet, one for power, and one for trigger signals. To connect power, use the optional Hirose 6-pin unterminated cable (part number 606-0672-xx) without a terminal block. Table 1 shows the power connections, table 2 shows the trigger connections.

To connect trigger signals, use one of two methods: a terminal block with a cable or an unterminated cable. Use a terminal block (248-0136) with the optional Hirose 12-pin to HD-15 camera cable (606-0673-xx). Without a terminal block, use the optional Hirose 12-pin to unterminated cable (part number 606-0671-xx).



**NOTE:** Do NOT use the M2xx/M3xx terminal block (248-0141) to connect this camera. It will NOT provide the correct signal levels.

**Table 1: Power Connections**

Cable Pin	Color	Signal Name	Notes
1	Blue	Camera Power VCC	+12 VDC (+-10%) @ 700 mA Max See Note below
2	Orange	Camera Power VCC	
3	Green	Not Connected	
4	Wht/Grn	Not Connected	
5	Wht/Org	Camera Power Ground	See Note 1 below
6	Wht/Blu	Camera Power Ground	

**NOTE 1:** Pins 1 and 2 are tied together inside of the camera. Pins 5 and 6 are tied together inside of the camera. To avoid a voltage drop when you use long wires between the power supply and the camera, we recommend providing camera power VCC through separate wires between the power supply and camera pins 1 and 2. We also recommend providing camera power ground through separate wires between the power supply and pins 5 and 6 on the camera.

**Table 2: Trigger Input Connections**

Terminal	Color	Signal Name	Notes
1	Wht/Blu	Input 1 Ground	No Connection
2	Wht/Org	Input 1 Plus	Frame Start Trigger Off: 0 to + 0.8 VDC On: +2.0 to +5 VDC Maximum: +5 VDC
3	Wht/Brn	Input 3 Ground	No Connection
4	Brn/Wht	Input 3 Plus	Phase B Line Trigger (Quadrature Encoder) Off: 0 to + 0.8 VDC On: +2.0 to +5 VDC Maximum: +5 VDC
5	Wht/Grn	Camera Trigger Ground	See Note 2 below
6	Wht/Gry	DO NOT USE	
7	Gry/Wht	DO NOT USE	

**Table 2: Trigger Input Connections**

Terminal	Color	Signal Name	Notes
8	Blu/Wht	Input 2 Ground	No Connection
9	Org/Wht	Input 2 Plus	Single Line Trigger <b>OR</b> Phase A Line Trigger (Quadrature Encoder) Off: 0 to + 0.8 VDC On: +2.0 to +5 VDC Maximum: +5 VDC
10	Grn/Wht	Not Connected	
11	Red/Blu	DO NOT USE	
12	Blu/Red	DO NOT USE	

---

**NOTE 2:** To help prevent ground loops and possible false triggering, we recommend connecting pin 5 on the Trigger Input (Camera Trigger Ground) to the ground on the Camera Power supply cable (pins 5 and/or 6).

---

## M5xx Circuit Diagrams (Older Terminal Blocks)

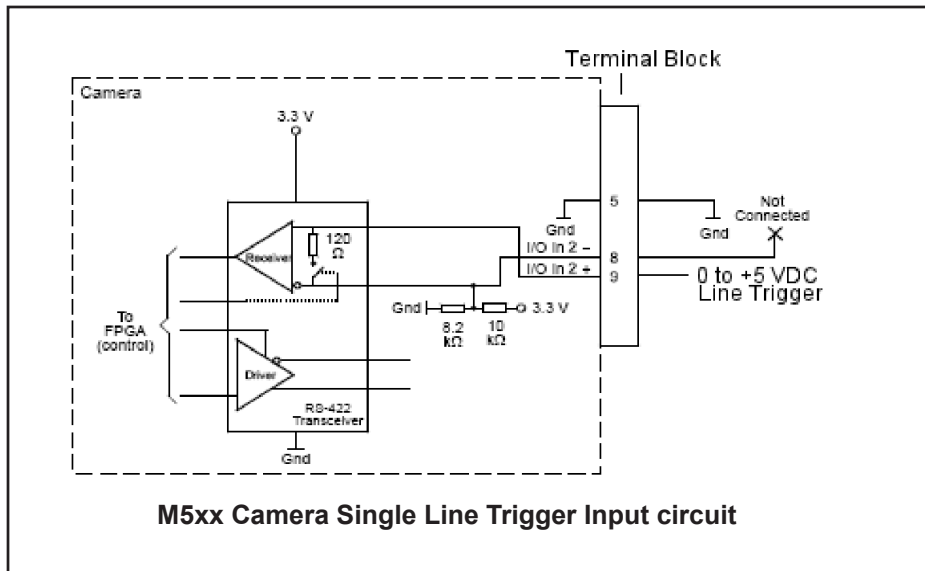
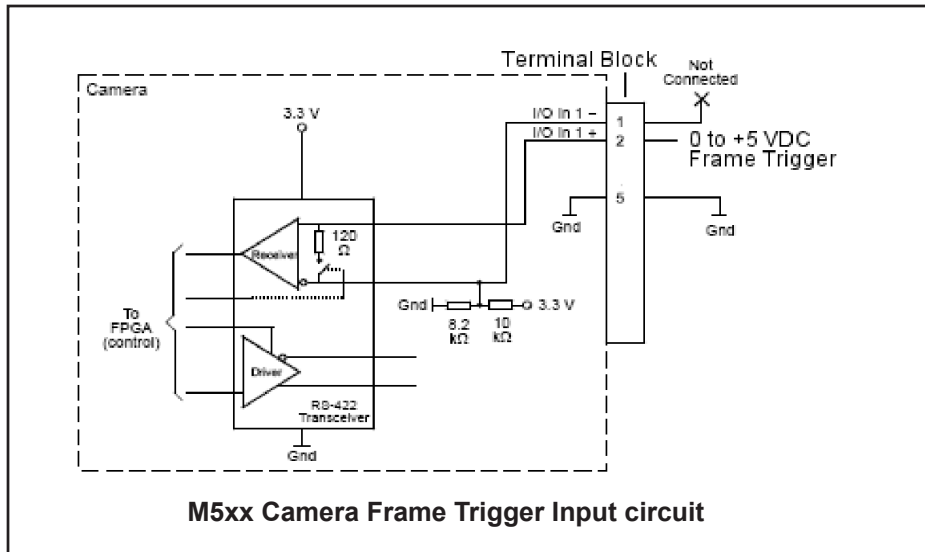



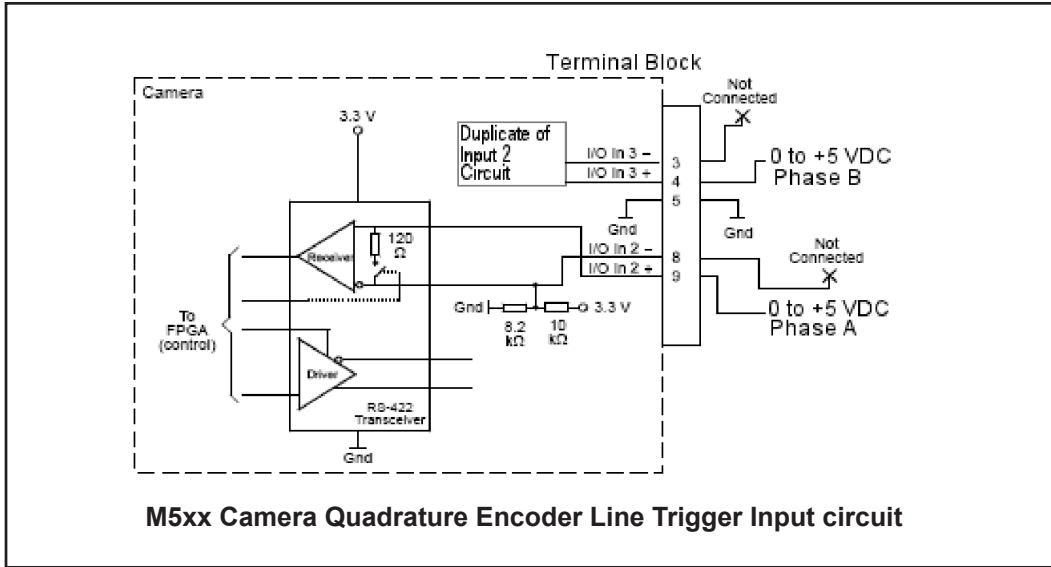

## M5xx Terminal Connections (Older Terminal Blocks)

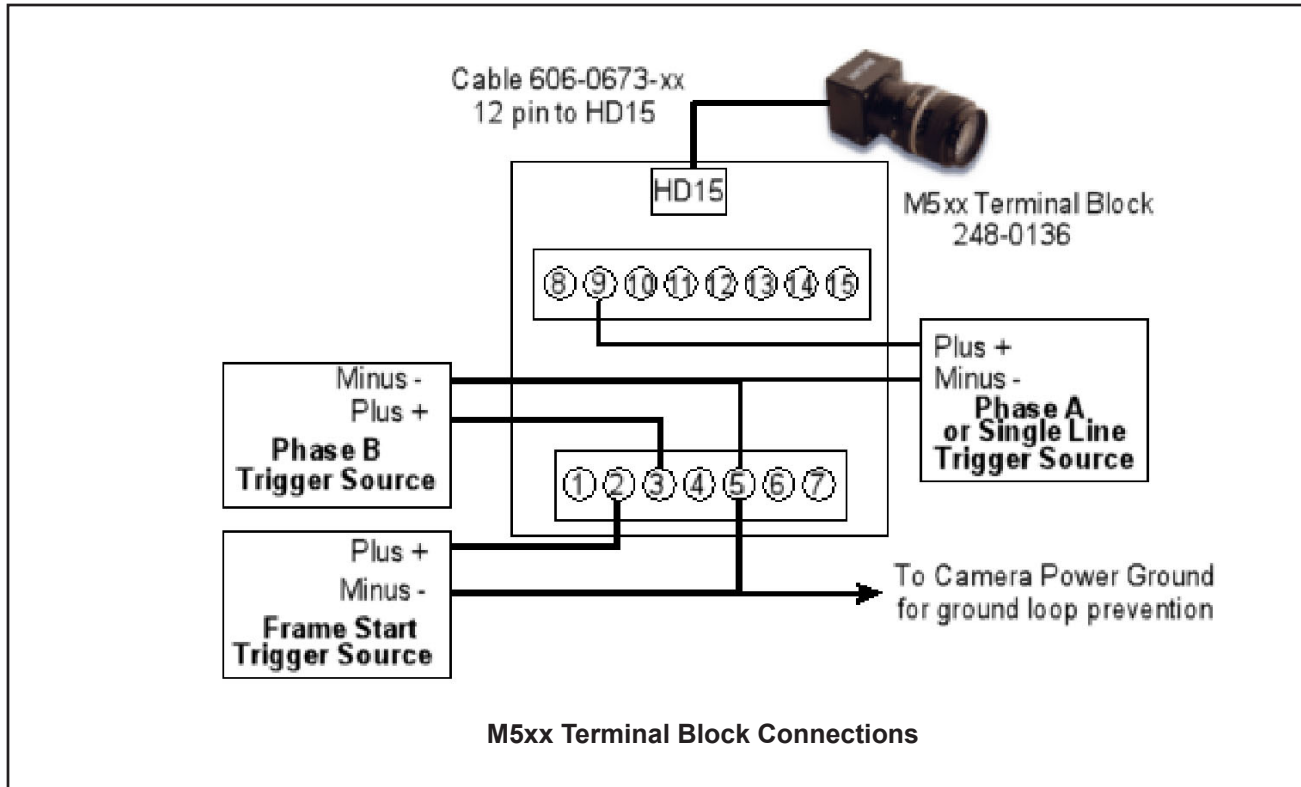

## M5xx Unterminated Cable Connections (Older Terminal Blocks)

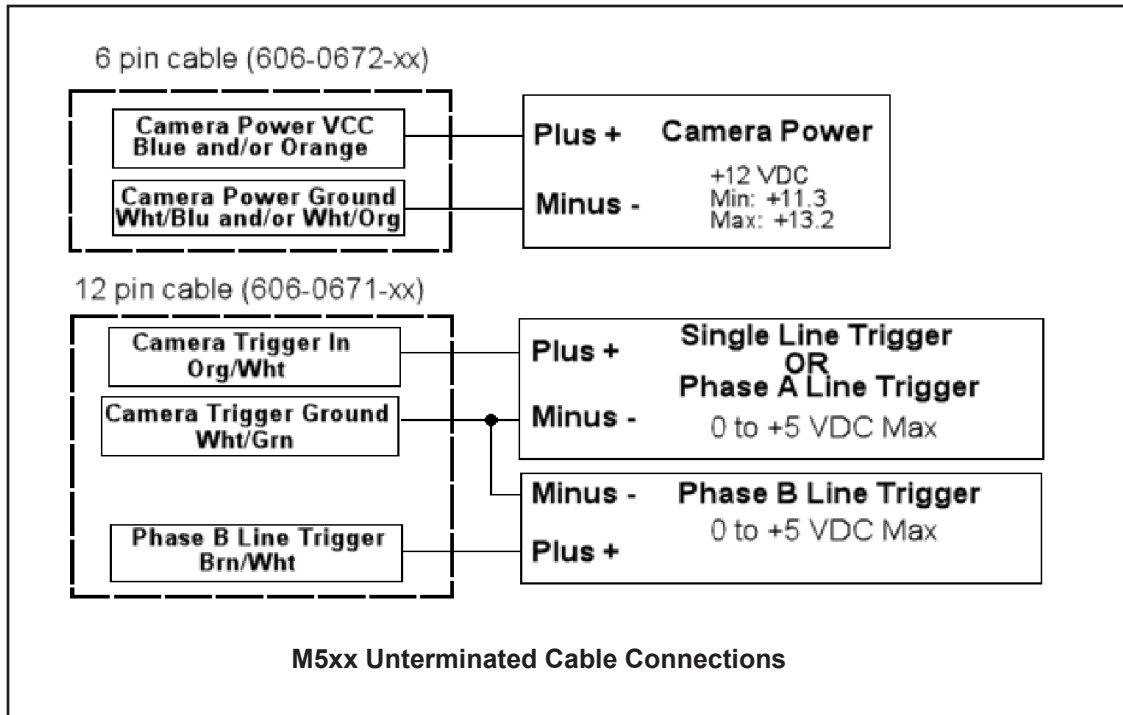

## Third-party Cameras (Older Terminal Blocks)

The M-Series Processor and Impact Software support only the third-party cameras listed in this section. This information, including power and trigger signal connections, are provided by us as a convenience. You must purchase a license from us to connect a third-party camera to the M-Series processor.

**We assume no responsibility for the accuracy or timeliness of this third-party camera information. For complete details and the most accurate specifications for these cameras, consult the manufacturer's documentation.**

## JAI Cameras (Older Terminal Blocks)

### JAI Camera Connection (Older Terminal Blocks)

Camera power, trigger signal, and strobe trigger can be connected to the camera using one of two methods: a terminal block with a cable or an unterminated cable. Use a terminal block (248-0136) with the optional Hirose 12-pin to HD-15 camera cable (606-0673-xx). Without a terminal block, use the optional Hirose 12-pin to unterminated cable (part number 606-0671-xx).

NOTE: Do NOT use terminal block 248-0141 to connect this camera. It will NOT provide the correct signal levels.

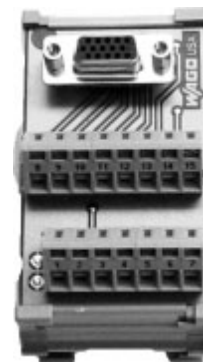

**WARNING: THE POWER AND GROUND CONNECTIONS FOR THIS CAMERA ARE DIFFERENT FROM OUR CAMERAS AND OTHER THIRD-PARTY CAMERAS. USE CAUTION WHEN CONNECTING POWER TO THESE CAMERAS.**

Terminal	Color	Signal Name	Notes
1	Wht/Blu	Camera Power Ground	See Note 1 below
2	Wht/Org	Camera Power VCC	<b>CM-140GE-UV and CM-030-GE-RH</b> +12 VDC @ 350 mA Max (4.1 W) Maximum: +13.2 VDC <b>AM-800GE</b> +12VDC to +24VDC ±10%, 8.16W (at normal, Full resolution, DC+12V) <b>AT-200GE</b> +10.8VDC to +26.4VDC, 0.67 A (Typical , Full frame, DC +12V in) See Note 1 below
3	Wht/Brn	DO NOT USE	
4	Brn/Wht	DO NOT USE	
5	Wht/Grn	Camera Trigger -	
6	Wht/Gry	Camera Trigger +	+0 to +24 VDC Off: 0 to + 1.4 VDC On: +3.3 to + 24 VDC Maximum: +24 VDC
7	Gry/Wht	Strobe Trigger -	270 Ohm 2W resistor between Gry/Wht wire and Strobe Power Ground
8	Blu/Wht	Strobe Trigger +	+5 to +24 VDC Maximum: +24 VDC
9	Org/Wht	DO NOT USE	
10	Grn/Wht	DO NOT USE	
11	Red/Blu	Camera Power VCC	See Note 1 below
12	Blu/Red	Camera Power Ground	See Note 1 below

**NOTE 1:** Pins 2 and 11 are tied together inside of the camera. Pins 1 and 12 are tied together inside of the camera. To avoid a voltage drop when there are long wires between your power supply and the camera, we recommend that you provide camera power VCC through separate wires between your power supply and pins 2 and 11 on the camera, and that you provide camera power ground through separate wires between your power supply and pins 1 and 12 on the camera.

## JAI Camera Circuit Diagrams (Older Terminal Blocks)

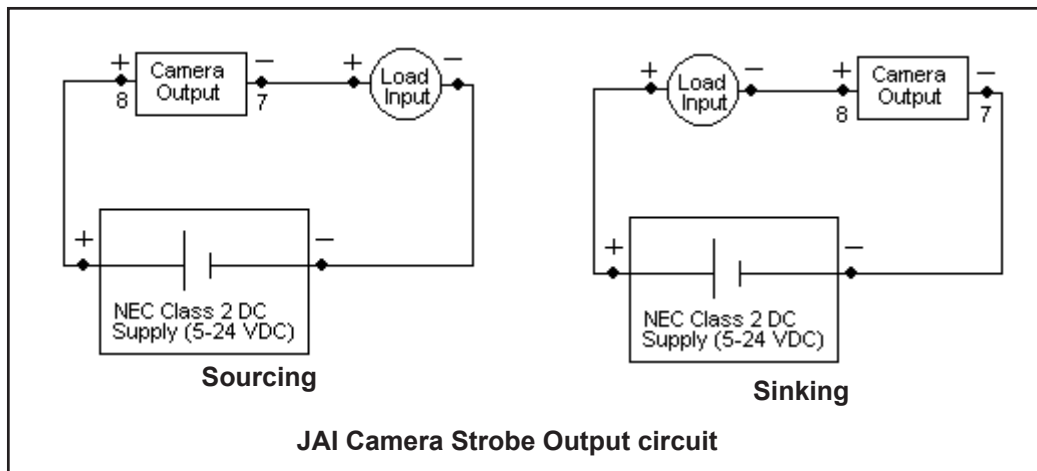
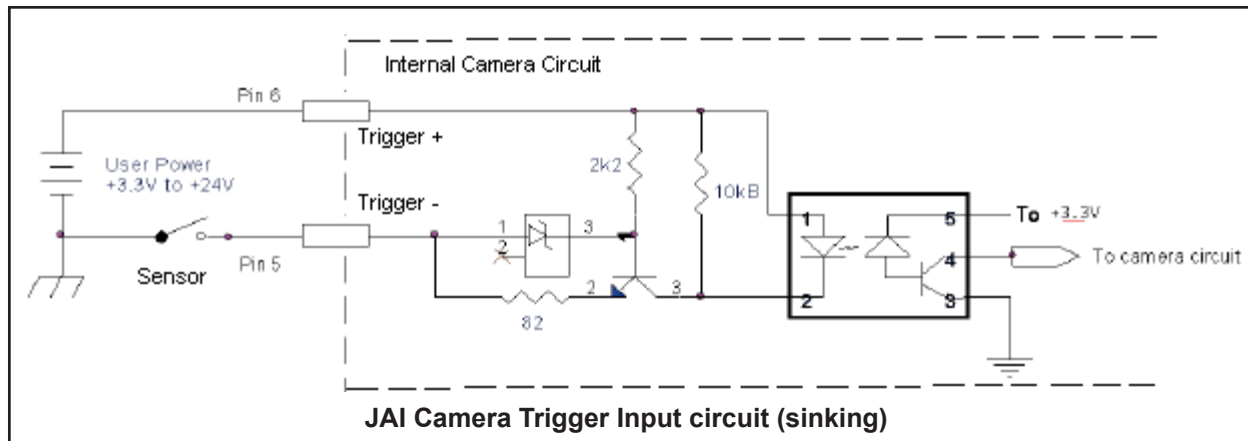
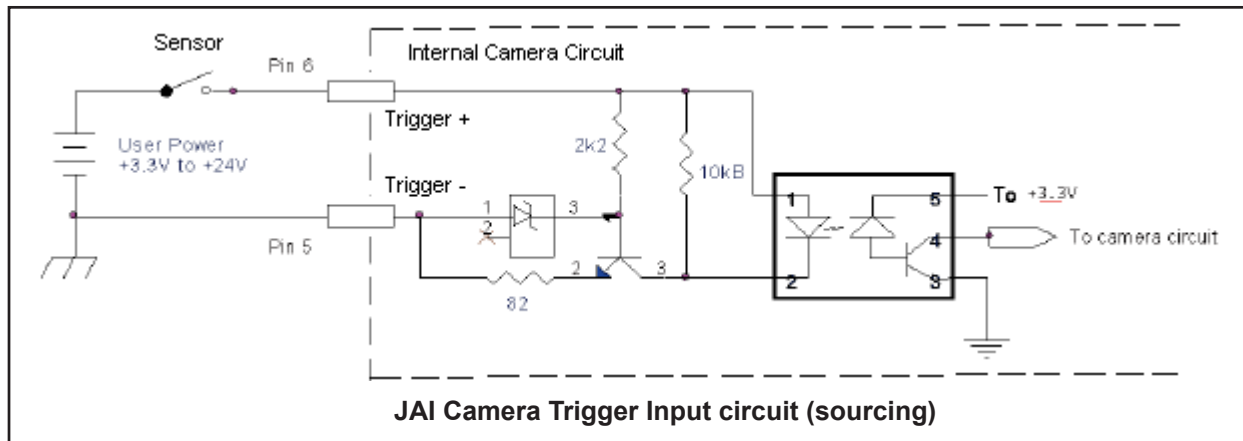

## JAI Terminal Connections (Older Terminal Blocks)

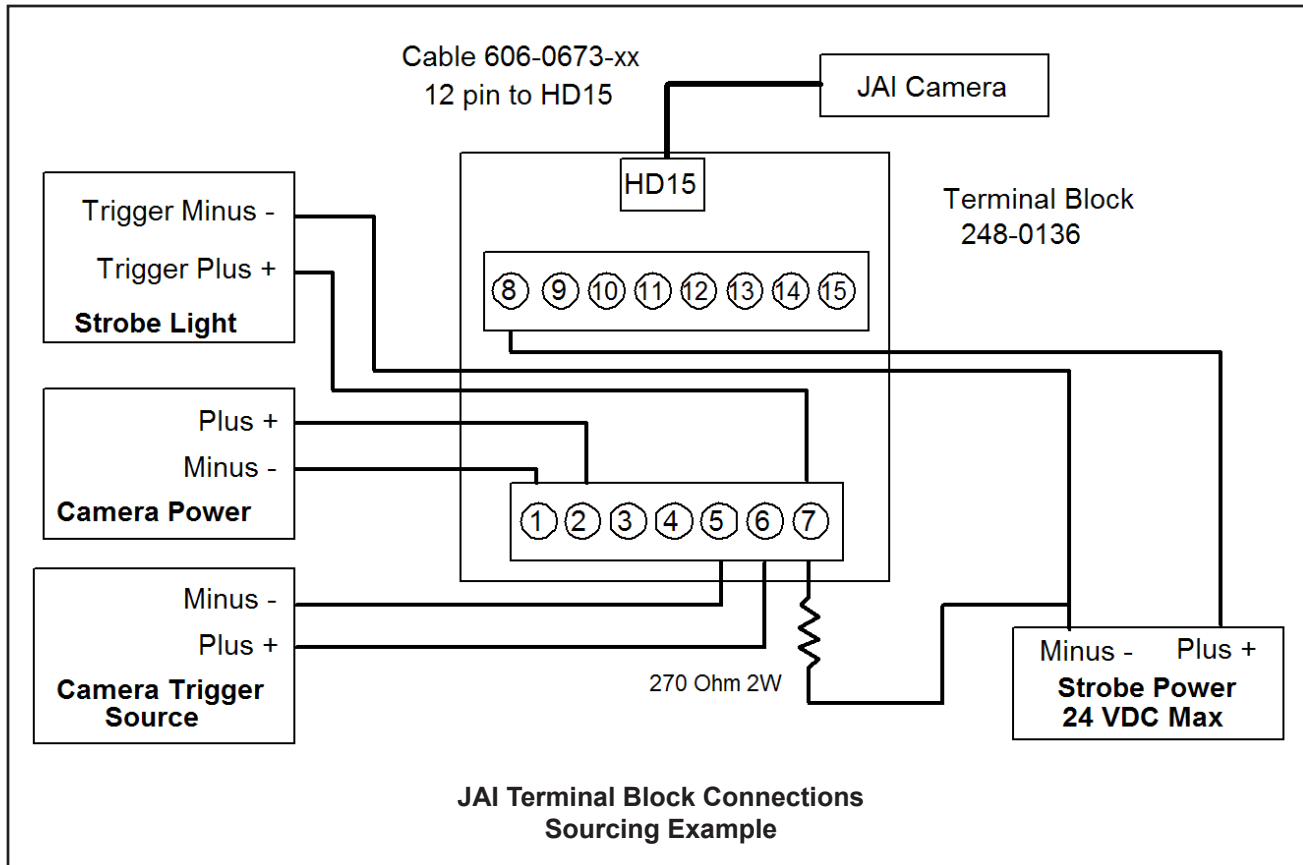

## JAI Unterminated Cable Connections (Older Terminal Blocks)

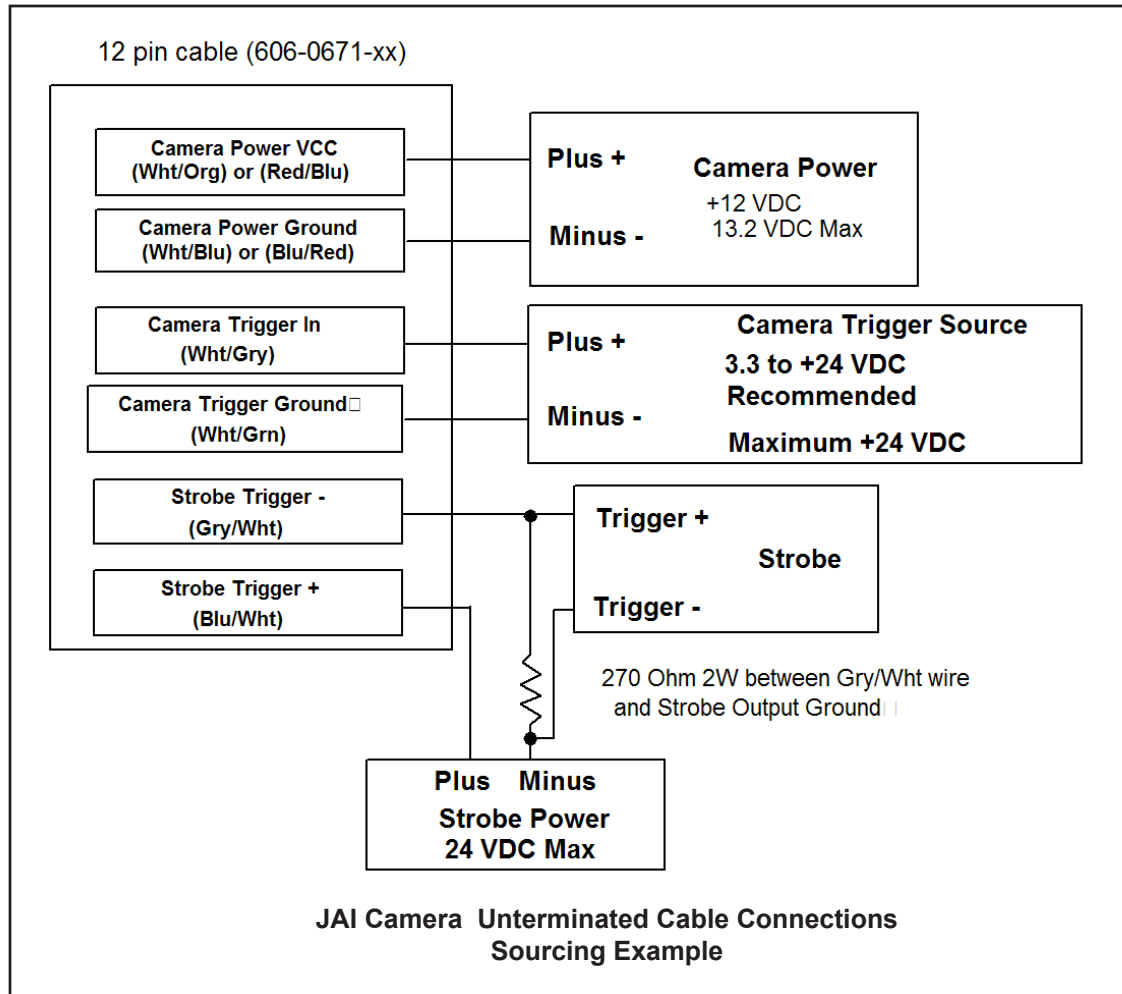

## JAI Camera I/O Signals

On JAI camera models AT200-GE and AM-800GE, the camera software setup in Vision Program Manager (VPM) provides a camera trigger delay debounce setting, but no holdoff debounce setting. VPM also does not provide a strobe trigger pulse width setting. The strobe trigger pulse width coincides with the camera shutter speed open time setting so that it turns on when the exposure starts (shutter opens) and turns off when the exposure ends (shutter closes). Refer to “Trigger Events” and “Strobe Pulse Length” in the Impact Reference Guide (843-0093) for more details.

## Basler Cameras (Older Terminal Blocks)

### Basler Camera Connection (Older Terminal Blocks)

**WARNING: THESE CAMERAS REQUIRE +12 VDC POWER. OUR CAMERA AND OTHER THIRD-PARTY CAMERA REQUIREMENTS ARE DIFFERENT. USE CAUTION WHEN CONNECTING POWER TO THESE**

**CAMERAS.**

Camera power, trigger signal, and strobe trigger can be connected to the camera using one of two methods: a terminal block and cable or an unterminated cable only. To use a terminal block (248-0141), you must also use the optional Hirose 12-pin to HD-15 camera cable (606-0673-xx). To connect the camera using an unterminated cable, use the optional Hirose 12-pin to unterminated cable (part number 606-0671-xx).

Terminal	Color	Signal Name	Notes
1 2	Wht/Blu Wht/Org	Camera Power Ground Camera Power Ground	See Note 1 below
3	Wht/Brn	Camera Trigger In	0 to +24 VDC recommended Off: 0 to + 1.4 VDC On: +2.2 to + 12VDC; 5 to 15 ma Maximum: +30 VDC
4	Brn/Wht	DO NOT USE	
5	Wht/Grn	Camera Trigger Ground	
6*	Wht/Gry	Strobe Trigger Out	
7	Gry/Wht	DO NOT USE	
8 9	Blu/Wht Org/Wht	Camera Power VCC Camera Power VCC	+12 VDC recommended @ 500 mA Max <b>Maximum: +13.2 VDC</b> See Note 1 below
10	Grn/Wht	Strobe VCC	Based on strobe requirement Maximum: +30 VDC; 50 ma
11	Red/Blu	DO NOT USE	
12	Blu/Red	DO NOT USE	
13*	None	Strobe Output Ground	(*Block contains 270 Ohm 2W resistor between terminals 6 and 13)

**NOTE 1:** Pins 1 and 2 are tied together inside of the camera. Pins 8 and 9 are tied together inside of the camera. To avoid a voltage drop when there are long wires between your power supply and the camera, we recommend that you provide camera power VCC through separate wires between your power supply and pins 8 and 9 on the camera. We also recommend that you provide camera power ground through separate wires between your power supply and pins 1 and 2 on the camera.



# Basler Camera Circuit Diagrams (Older Terminal Blocks)

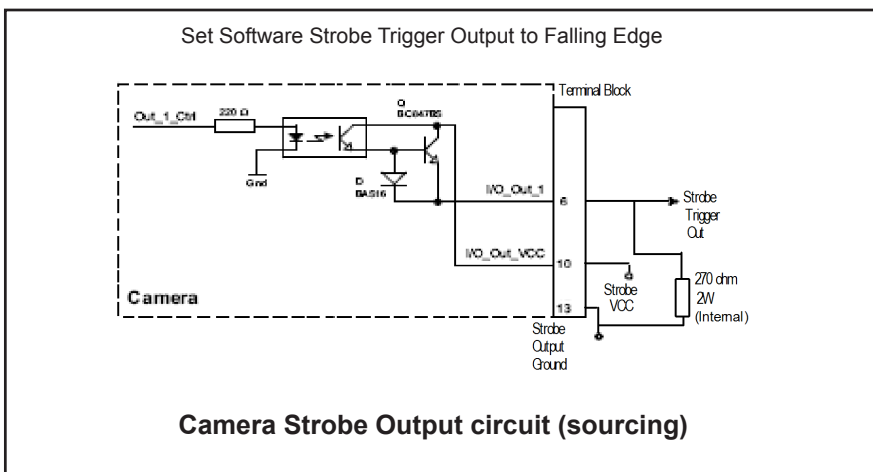
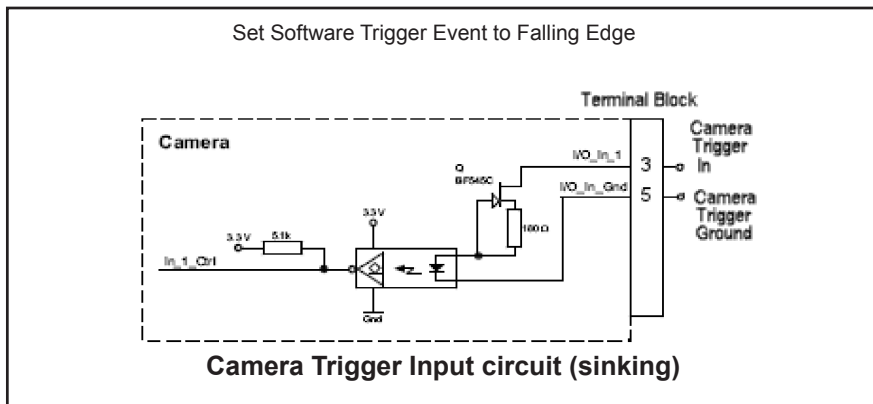
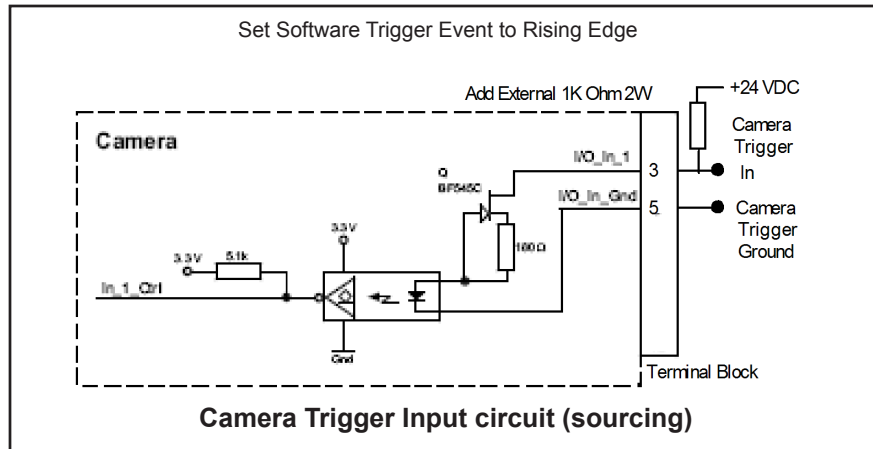

# Basler Camera Terminal Connections (Older Terminal Blocks)

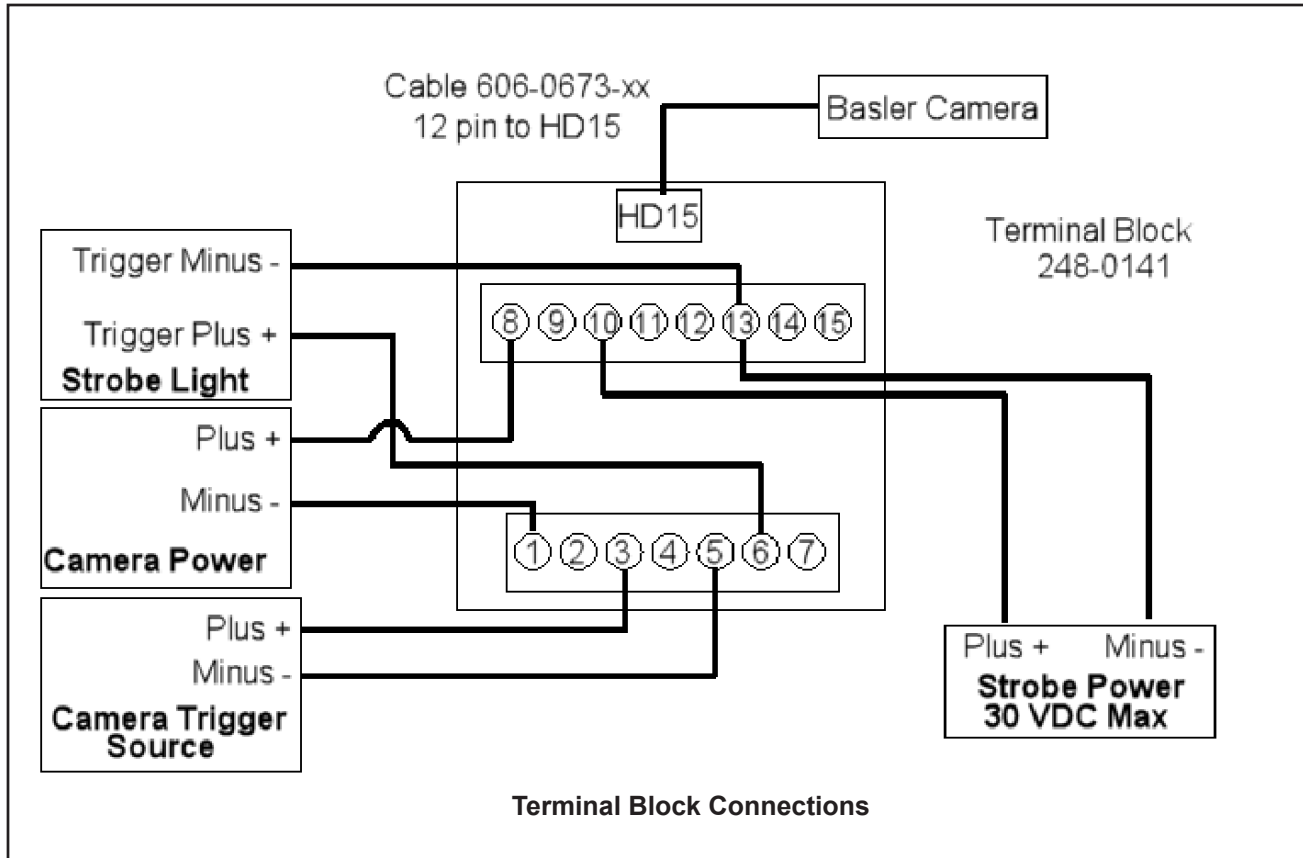

## Basler Unterminated Cable Connections (Older Terminal Blocks)

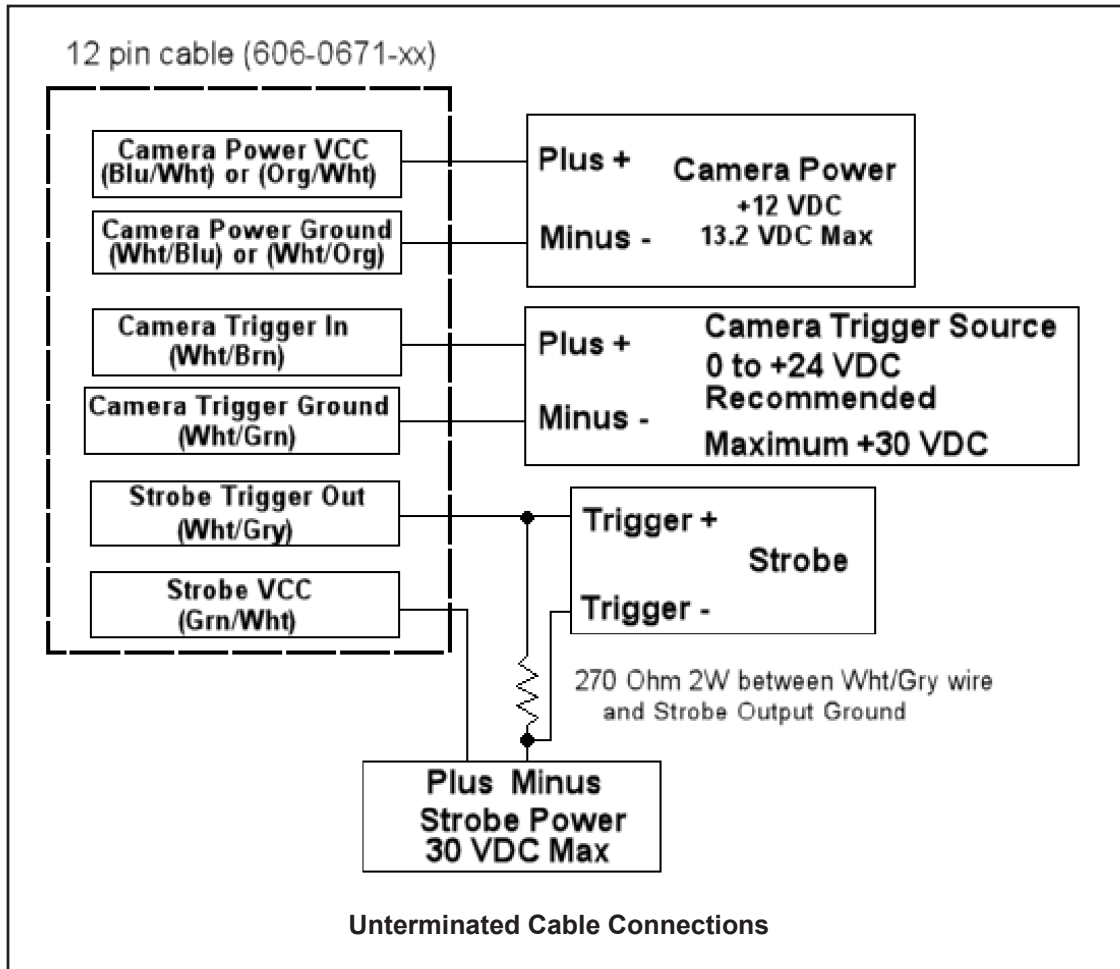

## SVS-Vistek Cameras (Older Terminal Blocks)

### SVS-Vistek Camera Connection

This camera uses two cables, one for Ethernet and one for power and trigger signals. For the Ethernet connection, use cable 606-0677-xx.

To connect power and trigger signals, use a terminal block (248-0136) with the optional Hirose 12-pin to HD-15 camera cable (606-0687-xx).

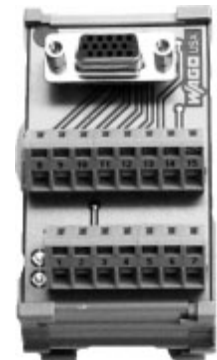

## Processor Input/Output (Older Terminal Blocks)

Two options for connecting to the older M-Series Processor I/O terminal block are listed in the table below. The cable wire color codes are listed in the following table.

The last two digits of the part number indicate the cable length in meters.

<b>Connector Type</b>	<b>Part Number</b>
Terminal Block - 37 pin D-sub to Screw Terminal	248-0110
I/O Cable - 37 pin D-sub Male to Male Cable (for use with above terminal block)	606-0675-xx
I/O Cable - 37 pin D-sub Male to Unterminated Cable	431-0592-xx

Connector or terminal number	Color Code	Signal Name
1 2	Black White	Input 1 and Event 1 + Input 3 +
3 4	Red Green	Input 5 + Input 7 +
5 6	Orange Blue	Input 9 + Input 11 +
7 8	White/Black Red/Black	Input 13 + Input 15 +
9 10	Green/Black Orange/Black	Input Common Output GND
11 12	Blue/Black Black/White	Output 1 + Output 3 +
13 14	Red/White Green/White	Output 5 + Output 7 +
15 16	Blue/White Black/Red	Output 9+ Output 11 +
17 18	White/Red Orange/Red	Output 13 + Output 15 +
19	Blue/Red	Output VDD *This is not an output voltage source.
20 21	Red/Green Orange/Green	Input 2 and Event 2 + Input 4 +
22 23	Black/White/Red White/Black/Red	Input 6 + Input 8 +
24 25	Red/Black/White Green/Black/White	Input 10 + Input 12 +
26 27	Orange/Black/White Blue/Black/White	Input 14 + Input 16 +
28 29	Black/Red/Green White/Red/Green	Output GND Output GND
30 31	Red/Black/Green Green/Black/Orange	Output 2 + Output 4 +
32 33	Orange/Black/Green Blue/White/Orange	Output 6 + Output 8 +
34 35	Black/White/Orange White/Red/Orange	Output 10 + Output 12 +
36 37	Orange/White/Blue White/Red/Blue	Output 14 + Output 16 +

Pin 1  
Pin 20

Pin 19  
Pin 37

<p><b>J1 (37 Pin "D" Sub Male)</b> AMP Part 747916-4 Part 244-0287 (Solder Side)</p>	<p><b>Hood Assembly with Screws</b> LEOCO Part DCHD-37MON4 Part 248-0089</p>
--	--

# Processor Older I/O Terminal Block

This diagram illustrates the 37 pin D-sub to Screw Terminal block (Part number 248-0110). This terminal block can be mounted on a DIN rail, then connected to the unit using a 37-pin cable (Part number 606-0675-xx). You can then wire from the terminal block to the controlled devices.

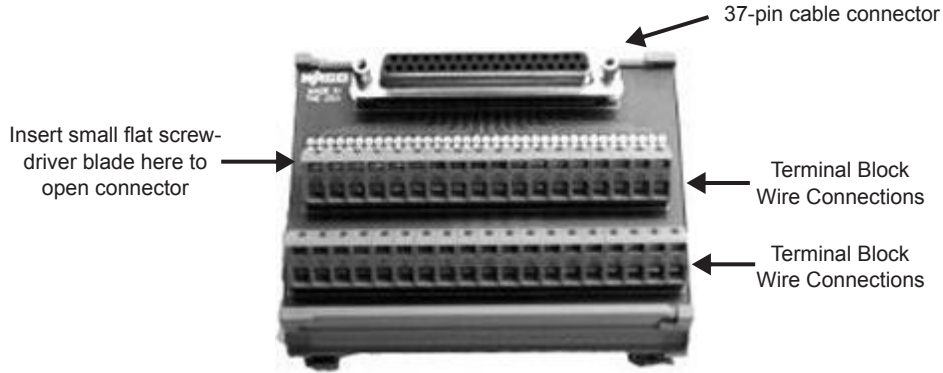

## General Purpose Older I/O Output Circuit (Sinking)

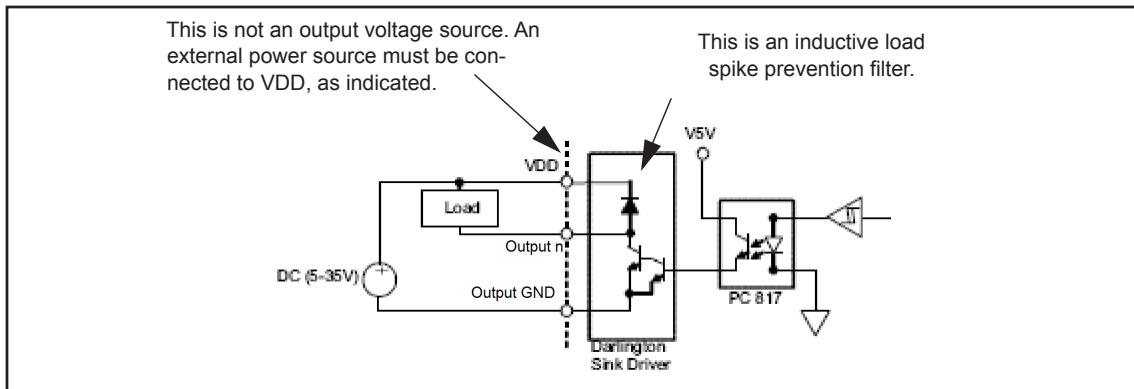

**NOTES:** To prevent output damage, all inductive loads must have noise suppressors connected directly across the load, as close to the load as possible.

Terminal 19 is not an output voltage source. An external power source must be connected to VDD.

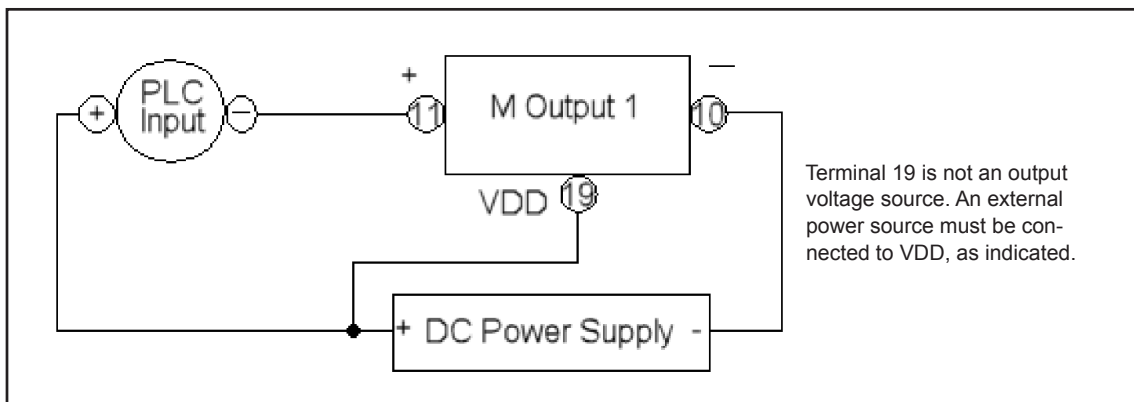

# General Purpose Older I/O Output Circuit (Sourcing)

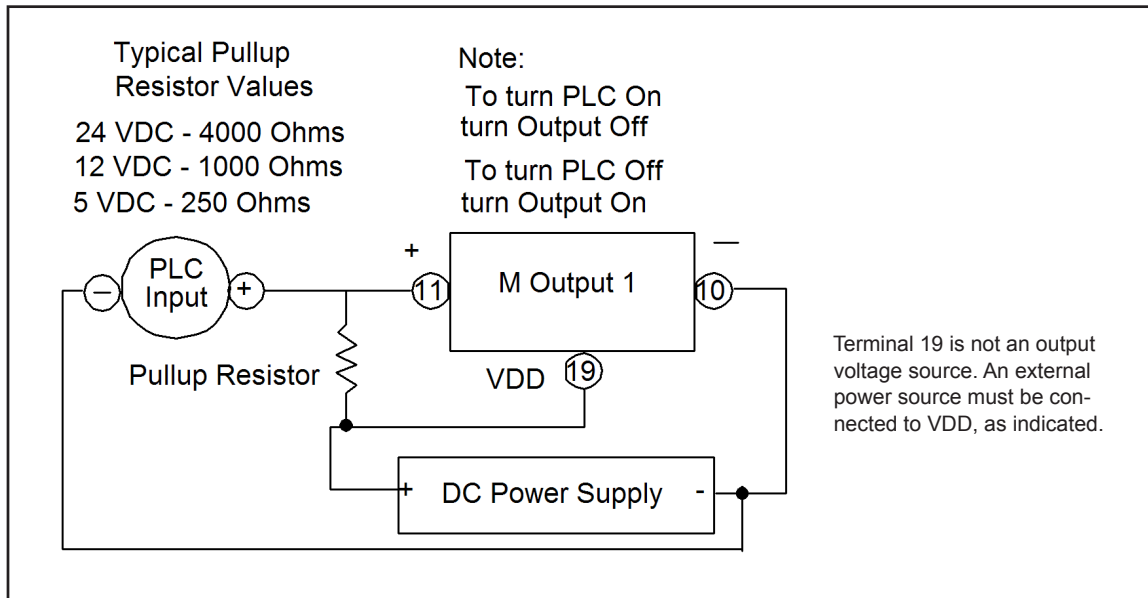

## Older Input I/O Circuit

The M-Series Processors contain sixteen general-purpose input connections.

Two inputs serve as both event and polled inputs (Inputs 1 and 2). The remaining inputs are polled. The event inputs are interrupt-driven which means that a change of state on the input will immediately cause an action and any inspection task that uses that input will run. Polled input means that the input’s status is checked based on conditions defined in the inspection task.

Interrupt-driven inputs are edge-triggered and the duration of the input pulse must be longer than the debounce time. The active trigger edge (rising, falling, or both), input pulse duration, and debounce, are all configured in the Vision Program Manager Settings tab.

This table describes the input characteristics.

Input Resistance (nominal)	Input Voltage	Turn On Voltage	Turn Off Voltage	Isolated Voltage
1.2k @ 0.5 W	0-24 Vdc	>3 Vdc	< 0.8 Vdc	2500 Vrms

This table lists the connector/terminal numbers for the input signals.

Connector and terminal number	Signal Name
1	Input1 and Event 1 +
2	Input 3 +
3	Input 5 +
4	Input 7 +

Connector and terminal number	Signal Name
5	Input 9 +
6	Input 11 +
7	Input 13 +
8	Input 15 +
9	Input Common
20	Input 2 and Event 2 +
21	Input 4 +
22	Input 6 +
23	Input 8 +
24	Input 10 +
25	Input 12 +
26	Input 14 +
27	Input 16 +

## Input Wiring

The diagrams below show two ways to wire a sensor to a general purpose or event input.

---

**Note:** All connections to inputs must be made using properly grounded shielded cable. All inputs must be wired as either sinking or sourcing, they cannot be mixed. There is only one “Input Common” connection for all the inputs.

---

### General Purpose Input Circuit (Sinking)

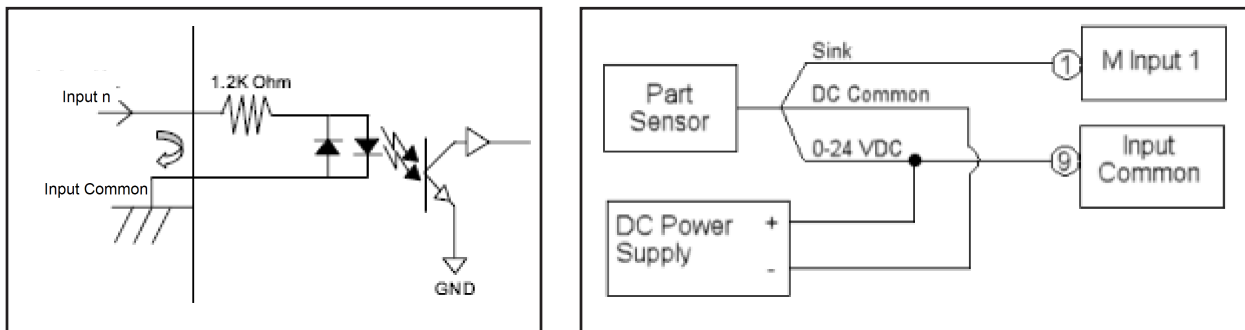



# General Purpose Input Circuit (Sourcing)

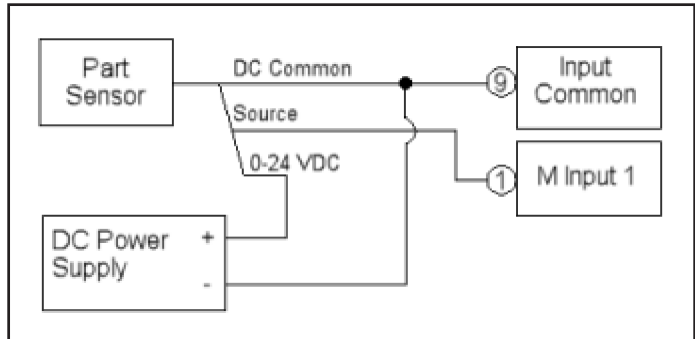
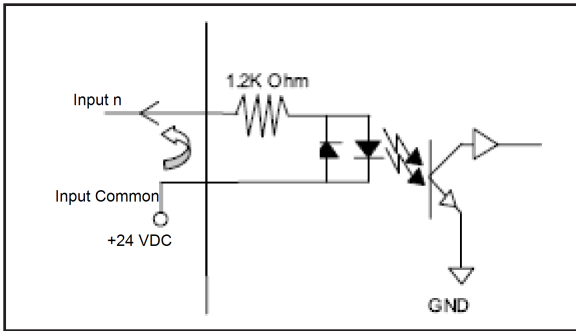



---

---

# M-SERIES PROCESSOR AND CAMERA GUIDE

## Index

### A

- AM-800GE 3-20
- Appendix 6-1
- AT-200GE 3-20, 3-26
- avA1000-100 3-28
- avA1600-50 3-28
- avA1900-50 3-28
- avA2300-25 3-28

### B

- Basler
  - camera 3-28
  - wiring 3-28

### C

- Cable
  - camera 5-1
  - ethernet 5-1
  - M1xx camera 5-3
  - M2xx camera 5-3
  - M3xx camera 5-3
  - M5xx camera 5-3
  - power 2-9, 2-10
  - serial 5-2
- Camera
  - Basler 3-28
  - cable 5-1
  - calibration 3-42
  - connector 1-5, 1-7
  - Dalsa 3-39
  - installation 3-2
  - JAI 3-20
  - mounting 3-7
  - M-Series 3-1
  - setup 3-42
  - Smartek 3-33
  - SVS-Vitek 3-38
  - temperature range 3-2
  - third-party 3-20
- Cfast compact flash 1-7
- Circuit
  - M2xx 3-13
  - M3xx 3-13
- CM-030GE-RH 3-20
- CM-140GE 3-20
- CM-140GE-UV 3-20
- Color shading
  - JAI 3-26
- COM
  - 1 1-5

- 2 1-6, 1-8, 5-2
- 3 1-8, 5-2
- 4 1-8, 5-2
- 5 1-7, 5-2
- Compact flash 1-5, 2-4, 2-5
  - Cfast 1-7
- Connector
  - camera 1-5, 1-7
  - DVI-I 1-7
  - ethernet 1-5, 1-7
  - I/O 1-5, 1-7
  - MX20 front 1-5
  - MX20 rear 1-6
  - MX40 front 1-5
  - MX40 rear 1-6
  - MX80 front 1-7
  - MX80 rear 1-8
  - power 2-9, 2-10
  - serial 1-5, 1-6, 1-7, 1-8, 5-2
  - USB 1-5, 1-6, 1-7
  - VGA 1-5

### D

- Dalsa
  - camera 3-39
- Debounce 4-2, 6-27
- Dimensions 2-1, 2-2
  - M1xx 3-3
  - M2xx 3-4
  - M3xx 3-5
  - M5xx 3-6
- processor 1-3
- DIN mounting 2-4
- DVI-I
  - connector 1-7
  - MX80 connector 5-3

### E

- eco204 3-38
- eco267 3-38
- eco274 3-38
- eco285 3-38
- eco414 3-38
- eco415 3-38
- eco424 3-38
- eco445 3-38
- eco618 3-38
- eco655 3-38
- Ethernet 5-1
  - connector 1-5, 1-7

### F

- Flash

- compact 1-5, 1-7, 2-4, 2-5
- Front connector
  - MX20 1-5
  - MX40 1-5
  - MX80 1-7

## H

- Hardware components 1-1

## I

- I/O
  - connector 1-5, 1-7
  - JAI 3-27
  - reference 4-1
- Input/Output
  - See I/O
- Inputs
  - processor 4-1
- Installation
  - processor 2-3
- Interrupts 4-2, 6-27

## J

- JAI
  - camera 3-20
  - camera, color shading 3-26
  - camera, I/O 3-27
  - wiring 3-20
- Jumper
  - pullup 4-3

## L

- Lights, status 2-7, 2-8

## M

- M100, M100C 3-43
- M110, M110C 3-44
- M115, M115C 3-45
- M125, M125C 3-46
- M150, M150C 3-47
- M180, M180C 3-48
- M190, M190C 3-49
- M195, M195C 3-50
- M1xx
  - cable 5-3
  - dimensions 3-3
  - mounting 3-7
  - specifications 3-43
  - wiring 3-8
- M200 line 3-51
- M202 line 3-52
- M210 line 3-53
- M230 line 3-54
- M250 line 3-55
- M270 line 3-56

- M290 line 3-57
- M295 line 3-58
- M2xx
  - cable 5-3
  - circuit 3-13
  - dimensions 3-4
  - mounting 3-7
  - specifications 3-51
- M300 line 3-59
- M330 line 3-60
- M350 line 3-61
- M390 line 3-62
- M3xx
  - cable 5-3
  - circuit 3-13
  - dimensions 3-5
  - mounting 3-7
  - specifications 3-59
- M510 3-63
- M520 3-64
- M530 3-64
- M540 3-64
- M550 3-65
- M560 3-65
- M5xx
  - dimensions 3-6
  - mounting 3-7
  - specifications 3-63
  - wiring 3-16
- Maintenance 1-9
- Mounting
  - camera 3-7
  - processor, DIN rail 2-4
  - processor, flat 2-4
- MX20
  - dimensions 2-1
  - front connector 1-5
  - power 2-9
  - rear connector 1-6
  - specifications 1-3
  - status lights 2-7
- MX40
  - dimensions 2-1
  - front connector 1-5
  - power 2-9
  - rear connector 1-6
  - specifications 1-3
  - status lights 2-7
- MX80
  - dimensions 2-2
  - front connectors 1-7
  - power 2-10
  - rear connector 1-8
  - specifications 1-3
  - status lights 2-8

## N

- Null modem 5-2

**O**

Older style terminal block 6-1

## Outputs

processor 4-3

**P**

## Port

DVI-I 1-7  
 ethernet 1-5, 1-7  
 I/O 1-5, 1-7  
 MX20 serial 5-2  
 MX40 serial 5-2  
 MX80 serial 5-2  
 serial 1-5, 1-6, 1-7, 1-8  
 USB 1-5, 1-6, 1-7  
 VGA 1-5

## Power

MX20 connection 2-9  
 MX40 connection 2-9  
 MX80 connection 2-10  
 processor specification 1-3  
 switch 1-6, 1-7

Preventive maintenance 1-9

## Processor

cable 5-1  
 Debounce 4-2, 6-27  
 DIN rail mounting 2-4  
 flat mounting 2-4  
 input wiring 4-2, 6-25  
 inputs 4-1  
 Interrupts 4-2, 6-27  
 MX20 dimensions 2-1  
 MX40 dimensions 2-1  
 MX80 dimensions 2-2  
 output wiring 4-4, 6-25  
 outputs 4-3  
 setup 1-3  
 specifications 1-3  
 wiring 4-1

Pullup jumper 4-3

**R**

## Rear connector

MX20 1-6  
 MX40 1-6  
 MX80 1-8

Reset 1-5, 1-7

**S**

## Safety

instructions 2-3  
 precautions 1-2, 3-1

## Serial

connector 1-5, 1-6, 1-7, 1-8  
 MX20 connector 5-2  
 MX40 connector 5-2

MX80 connector 5-2

## Setup

processor 1-3

## Smartek

camera 3-33  
 wiring 3-33

## Specifications

M1xx 3-43  
 M2xx 3-51  
 M3xx 3-59  
 M5xx 3-63  
 processor 1-3

Status lights 2-7, 2-8

Support, technical 1-9

## SVS-Vistek

camera 3-38  
 wiring 3-38, 3-40

## Switch

power 1-6, 1-7

**T**

Technical support 1-9

## Temperature range

camera 3-2  
 processor 1-3

## Terminal block

Basler 3-28  
 JAI 3-20  
 M1xx 3-8  
 M2xx 3-12  
 M3xx 3-12  
 M5xx 3-16  
 older style 6-1  
 processor 4-1  
 Smartek 3-33  
 SVS-Vistek 3-38, 3-40

Third-party camera 3-20

**U**

## USB connector

2.0 1-5, 1-6, 1-7  
 3.0 1-7

**V**

## VGA

MX40 connector 5-2  
 MX80 connector 5-3

VGA connector 1-5

**W**

## Weight

M1xx 3-3  
 M2xx 3-4  
 M3xx 3-5  
 M5xx 3-6  
 processor 1-3

## Wiring

- Basler 3-28
- JAI 3-20
- M1xx 3-8
- M2xx 3-12
- M3xx 3-12
- M5xx 3-16
- processor 4-1
- processor I/O 6-25
- processor input 4-2
- processor output 4-4
- Smartek 3-33
- SVS-Vistek camera 3-38, 3-40